

Denna ritning får inte utan Tetra Paks medgivande kopieras, utlämnas till eller delgivas tredje man.  
 This drawing must not without the consent of Tetra Pak be copied, transmitted or disclosed to any third party.

Övriga toleranser och fördringar enligt Tetra Paks Underleverantörspecifikationer (US).  
 Other tolerances and requirements according to Tetra Paks Specifications for Sub-Contractors (US).

Not Note	Ändring Alteration	Datum Date	Sign.	Not Note	Ändring Alteration	Datum Date	Sign.
--	INF AM 19260	930310	HK				

100mm  
90  
80  
70  
60  
50  
40  
30  
20  
10  
0

# EM

Machine: TBA/9

No:

Spec: 649205-1401

ELECTRICAL MANUAL

Där ej annat anges/Unless otherwise stated <b>SKARPA KANTER BRUTNA/SHARP EDGES BROKEN</b>		Designer <b>HK</b>	<b>Marked with PART NUMBER</b>																	
Gjutgods Castings..... KA 21 11.10 Svetsade konstr./Welded constr. KA 21 11.50		Date <b>930310</b>		Method...../.....mm - KA2103.10	Assembly drawing															
Maskinbearb.ytor/Machined surfaces KA 21 11.30		Approved	Material																	
<table border="1" style="font-size: small; width: 100%;"> <thead> <tr> <th>Basic size</th> <th>Tol.</th> <th>Basic size</th> <th>Tol.</th> </tr> </thead> <tbody> <tr> <td>(1)- 6</td> <td>0.1</td> <td>(120)- 315</td> <td>0.5</td> </tr> <tr> <td>(6)- 30</td> <td>0.2</td> <td>(315)-1000</td> <td>0.8</td> </tr> <tr> <td>(30)-120</td> <td>0.3</td> <td>(1000)-2000</td> <td>1.2</td> </tr> </tbody> </table>		Basic size	Tol.	Basic size	Tol.	(1)- 6	0.1	(120)- 315	0.5	(6)- 30	0.2	(315)-1000	0.8	(30)-120	0.3	(1000)-2000	1.2	Scale <b>1 : 1</b>	Surface roughness	
Basic size	Tol.	Basic size	Tol.																	
(1)- 6	0.1	(120)- 315	0.5																	
(6)- 30	0.2	(315)-1000	0.8																	
(30)-120	0.3	(1000)-2000	1.2																	
<table border="1" style="font-size: x-small; width: 100%;"> <thead> <tr> <th>Basic size</th> <th>Tol.</th> <th>Basic size</th> <th>Tol.</th> </tr> </thead> <tbody> <tr> <td>(1)- 6</td> <td>0.1</td> <td>(120)- 315</td> <td>0.5</td> </tr> <tr> <td>(6)- 30</td> <td>0.2</td> <td>(315)-1000</td> <td>0.8</td> </tr> <tr> <td>(30)-120</td> <td>0.3</td> <td>(1000)-2000</td> <td>1.2</td> </tr> </tbody> </table>		Basic size	Tol.	Basic size	Tol.	(1)- 6	0.1	(120)- 315	0.5	(6)- 30	0.2	(315)-1000	0.8	(30)-120	0.3	(1000)-2000	1.2		Surface treatment	
Basic size	Tol.	Basic size	Tol.																	
(1)- 6	0.1	(120)- 315	0.5																	
(6)- 30	0.2	(315)-1000	0.8																	
(30)-120	0.3	(1000)-2000	1.2																	
<b>TETRA PAK</b> <small>LUND SWEDEN</small>		<b>LABEL</b> <b>TBA/9-1401 S.A.</b>		<b>4-570 929</b>																

		1	BE-LIST
		2	
A	20555 940916 HK/MRT	3	CE-LIST, CONTROL CABINET
ECN 19260		4	CONTROL PANEL
		5	MACHINE
		6	EQUIPMENT
		7	EXTRA EQUIPMENT
		8	SPARE PART KIT
	4-571516		9
		10	ELECTRICAL DOCUMENTS
		11	CIRCUIT DIAGRAM, POSITION SUMMARY
		12	DRAWINGS
		13	GROUND CONNECTION
		14	LINE SUMMARY
DATE: 930310 SIGN: HK/UTH		15	TERMINAL SUMMARY
		16	ALTERATION MESSAGES
		17	
		18	PLC, LIST OF BLOCKS
INDEX FOR TBA/9-1401		19	LIST OF ADDRESSES
		20	VARIANT SETTING
		21	SEQUENCE DIAGRAM
		22	FUNCTIONS
		23	MOUNT. DRAWINGS, CONTROL CABINET
		24	CONTROL PANEL
		25	MACHINE
		26	TPIH CABINET
TETRA PAK		27	CONNECTION DIAGRAM
		28	MAINS CONNECTION
		29	TERMINALS
		30	FUSE PANEL LABEL
		31	

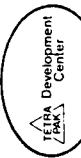

USED IN ASSEMB. 648152

ECN NUMBER: EC 17786 EC 17872 EC 17873 EC 19260 EC 19261 EC 19262 EC 19721 EC 20080  
 DATE DISTRIBUTED 93-01-19 93-01-19 93-01-19 93-03-17 93-03-17 93-03-17 93-04-20 93-09-15

GROUP

VARIANT DESCRIP: -1401 TBA/9-1401 S.A.  
 -1402 TBA/9-1402 P.T.  
 -1403 TBA/9-1403 C.

POS	PART TITLE / REMARKS	PART NUMBER	R	SP	UN	1401	1402	1403
0010	CTRL CAB. TBA/9-1401 S.A.	CE- 41723-0101	-			1	-	-
0020	CTRL.PAN. TBA/9-1401 S.A.	CE- 41724-0101	-			1	-	-
0030	MACHINE	CE- 41725-0101	-			1	-	-
0040	EQUIPMENT TBA/9-1401 S.A.	CE- 41726-0101	-			1	-	-
0050	EXTRA EQU TBA/9-1401 S.A.	CE- 41727-0101	-			1	-	-
0060	SP. PARTS TBA/9-1401 S.A.	CE- 41728-0101	-			1	-	-
0070	EL-DOC. TBA/9-1401 S.A.	CE- 41729-0101	-			1	-	-
0080	EL-EQUIPMENT TPIH	CE- 41766-0101	-			1	1	1
0090	CTRL CAB. TBA/9-1402 P.T.	CE- 41750-0101	-			-	1	-
0100	CTRL.PAN. TBA/9-1402 P.T.	CE- 41751-0101	-			-	1	-
0110	MACHINE TBA/9-1402 P.T.	CE- 41752-0101	-			-	1	-
0120	EQUIPMENT TBA/9-1402 P.T.	CE- 41753-0101	-			-	1	-
0130	EXTRA EQU TBA/9-1402 P.T.	CE- 41754-0101	-			-	1	-
0140	SP. PARTS TBA/9-1402 P.T.	CE- 41755-0101	-			-	1	-
0150	EL-DOC. TBA/9-1402 P.T.	CE- 41756-0101	-			-	1	-
0160	EL-EQUIPMENT IH-GENERATOR	BE- 649411-0101	-			-	1	-
0170	ELECTRIC MATERIALS	CE- 69884-0101	-			-	1	-
0180	ELECTRICAL DOCUMENT	CE- 69885-0101	-			-	1	-
0190	ELECTRIC MATERIALS	CE- 69886-0101	-			-	1	-
0200	ELECTRICAL DOCUMENT	CE- 69887-0101	-			-	1	-
0210	CTRL CAB. TBA/9-1403 C.	CE- 41757-0101	-			-	-	1
0220	CTRL.PAN. TBA/9-1403 C.	CE- 41758-0101	-			-	-	1
0230	MACHINE TBA/9-1403 C.	CE- 41759-0101	-			-	-	1
0240	EQUIPMENT TBA/9-1403 C.	CE- 41760-0101	-			-	-	1
0250	EXTRA EQU TBA/9-1403 C.	CE- 41761-0101	-			-	-	1
0260	SP. PARTS TBA/9-1403 C.	CE- 41762-0101	-			-	-	1



BILL-OF-MATERIAL "0"

DATE PRINTED: 93-09-15

POS	PART TITLE / REMARKS	PART NUMBER	R	SP	UN	1401	1402	1403
0270	EL-D00C. TBA/9-1403 C.	CE- 41763-0101	-	-	-	-	-	1



USED IN ASSEMB. 41729 649205

ECN NUMBER: EC 17786 EC 19260 EC 20080 EC 20398 EC 20406  
DATE DISTRIBUTED 93-01-19 93-03-17 93-09-15 93-10-01 93-10-18

POS	PART TITLE / REMARKS	PART NUMBER	R	SP	UN	0101
	MOUNTING DRAWING, CABINET	4- 52471-05101	X			
	MOUNTING DRAWING, CABINET	4- 52471-06101	X			
	MOUNTING DRAWING, CABINET	4- 52471-07101	X			
	MOUNTING DRAWING, CABINET	4- 52471-08101	X			
	MOUNTING DRAWING, CABINET	4- 52471-09101	X			
	MOUNTING DRAWING, CABINET	4- 52471-10101	X			
	MOUNTING DRAWING, RACK	4- 52471-11101	X			
A001:1	BACKPLANE FRONT RACK BTE	C- 68262-0101	S			1
A16A	PRINTED DESIGN CORR.LOGIC	C- 68471-0101	S			1
A16A:1	BACKPLANE FRONT RACK BTE	C- 68262-0101	S			1
A16B	CIRCUIT BOARD	C- 67058-0301	S			1
A16B:1	BACKPLANE FRONT RACK BTE	C- 68262-0101	S			1
A16B:2	FRONT FLATE	C- 68445-0106	S			1
R110	CIRCUIT BOARD	C- 68444-0101	US			1
0010	RACK	C- 67388-0102	C			1
0010:1	FRONT FLATE	C- 68445-0106	S			2
0010:2	FRONT FLATE	C- 68445-0101	S			2
0010:3	FRONT FLATE	C- 68445-0102	S			2
0010:4	FRONT FLATE	C- 68445-0103	S			2
0010:5	FRONT FLATE	C- 68445-0104	S			2
0010:6	FRONT FLATE	C- 68445-0105	S			2
A001	MOTOR DRIVE CONTROL	2- 90430-0037	S			1
A002	SAFETY RELAY	2- 90119-0072	C			1
A004	TEMPERATURE REGULATOR	2- 90410-0044	P			1
A004:1	SIGN"PRESTERILISATION V."	359241-0123	C			1
A006	TEMPERATURE REGULATOR	2- 90410-0044	P			1
A006:1	SIGN"PEROXIDE BATH WATER"	359241-0141	C			1
A008	TEMPERATURE REGULATOR	2- 90410-0044	P			1
A008:1	SIGN"LONGITUDINAL SEALING	359241-0131	C			1
A010	TEMPERATURE REGULATOR	2- 90410-0044	P			1



POS	PART TITLE / REMARKS	PART NUMBER	R	SP	UN	Q101
A010:1	SIGN"AIR SUPER HEATER"	359241-0130	C			1
A013	TEMPERATURE REGULATOR	2- 90410-0044	P			1
A013:1	SIGN"TEMP" AIR KNIFE"	359241-0126	C			1
A014	TEMPERATURE REGULATOR	2- 90410-0044	P			1
A014:1	SIGN"STEAM"	359241-0121	C			1
A015	LEVEL REGULATOR	2- 90314-0021	S			1
A017	LEVEL REGULATOR	2- 90314-0021	S			1
A018	LEVEL REGULATOR	2- 90314-0021	S			1
A019	LEVEL REGULATOR	2- 90314-0021	S			1
A022	LEVEL REGULATOR	2- 90314-0021	S			1
A023	OPTO-RELAY	3- 90119-0063	-			-
* SEE TERMINAL DRWG: 571519						
A024	OPTO-RELAY	3- 90119-0063	-			-
* SEE TERMINAL DRWG: 571519						
A025	OPTO-RELAY	3- 90119-0063	-			-
* SEE TERMINAL DRWG: 571519						
A030	TEMPERATURE REGULATOR	2- 90410-0044	P			1
A030:1	SIGN"TEMP" PEROXIDE BATH"	359241-0125	C			1
A101	ENCODER MODULE	2- 90025-0016	S			1
A101:1	TERMINAL BLOCK	3- 90025-0025	C			1
A102	INFUT MODULE	2- 90025-0017	S			1
A102:1	TERMINAL BLOCK	3- 90025-0024	C			1
A103	INFUT MODULE	2- 90025-0017	S			1
A103:1	TERMINAL BLOCK	3- 90025-0024	C			1
A104	INFUT MODULE	2- 90025-0017	S			1
A104:1	TERMINAL BLOCK	3- 90025-0024	C			1
A105	INFUT MODULE	2- 90025-0017	S			1
A105:1	TERMINAL BLOCK	3- 90025-0024	C			1
A106	INFUT MODULE	2- 90025-0017	S			1
A106:1	TERMINAL BLOCK	3- 90025-0024	C			1
A108	RACK	1- 90025-0052	C			1
A114	OUTPUT MODULE	2- 90025-0053	S			1
A114:1	TERMINAL PLINTH	3- 90025-0054	C			1
A115	OUTPUT MODULE	2- 90025-0053	S			1



PDS	PART TITLE / REMARKS	PART NUMBER	R	SF	LN	Q101
A115:1	TERMINAL PLINTH	3- 90025-0054	C			1
A116	OUTPUT MODULE	2- 90025-0053	S			1
A116:1	TERMINAL PLINTH	3- 90025-0054	C			1
A117	OUTPUT MODULE	2- 90025-0053	S			1
A117:1	TERMINAL PLINTH	3- 90025-0054	C			1
A118	RACK	1- 90025-0058	C			1
A120	OUTPUT MODULE	2- 90025-0053	S			1
A120:1	TERMINAL PLINTH	3- 90025-0054	C			1
A121	OUTPUT MODULE	2- 90025-0053	S			1
A121:1	TERMINAL PLINTH	3- 90025-0054	C			1
A128	RACK	1- 90025-0058	C			1
A202	TEMPERATURE REGULATOR	2- 90410-0044	F			1
A202:1	SIGN"STRIP APPLICATOR"	359241-0132	C			1
A450	RELAY	3- 90119-0070	S			1
USE 90119-77						
NOT A GENERAL REPLACEMENT						
A451	RELAY	3- 90119-0070	S			1
USE 90119-77						
NOT A GENERAL REPLACEMENT						
D108	PROCESSOR	1- 90025-0070	C			1
D108:1	ADAPTER	3- 90025-0096	C			1
D108:2	TERMINAL PLINTH	3- 90025-0031	C			1
E004	HOLDING FIXTURE	3- 90164-0301	S			1
E004:1	FLUORESCENT TUBE 11W	90297-0007	P			1
F001	FUSE 1P 10A K	3- 90007-0129	S			1
F003	FINE-WIRE 1,6 A	3- 352550-0133	UP			-
* SEE TERMINAL DRWG: 571519						
F003:1	FUSE TERMINAL	353023-0102	C			-
* SEE TERMINAL DRWG: 571519						
F005	FUSE 1P 16A K	3- 90007-0131	S			1
F008	FUSE 1P 10A K	3- 90007-0129	S			1
F010	TUBE FUSE 12A	4- 90233-0027	UP			1
F010:1	FUSE HOLDER	3- 90077-0112	S			1



FDS	PART TITLE / REMARKS	PART NUMBER	R	SP	UN	QTY
F017	FUSE 1P 6A K	3- 90007-0128		UP		1
F019	FUSE 1P 6A K	3- 90007-0128		UP		1
F028	TUBE FUSE 16A	4- 90233-0027		UP		3
F028:1	FUSE HOLDER	3- 90077-0112		S		3
F029	TUBE FUSE	4- 90233-0029		UP		3
F029:1	FUSE HOLDER	3- 90077-0112		S		3
F030	TUBE FUSE 10A	4- 90233-0028		UP		1
F030:1	FUSE HOLDER	3- 90077-0112		S		1
F031	TUBE FUSE 10A	4- 90233-0028		UP		1
F031:1	FUSE HOLDER	3- 90077-0112		S		1
F041	FUSE H. MANN 2P 80A 2	1- 90007-0118		S		1
F042	FUSE H. MANN 2P 80A 2	1- 90007-0118		S		1
F055	FUSE 3P 10A K	3- 90007-0147		S		1
F056	TUBE FUSE 10A	4- 90233-0028		UP		3
F056:1	FUSE HOLDER	3- 90077-0112		S		3
F202	TUBE FUSE 16A	4- 90233-0027		S		1
F202:1	FUSE HOLDER	3- 90077-0112		S		1
G100	POWER SUPPLY UNIT	2- 90025-0055		S		1
K002	CONTACTOR 7,5KW	2- 90075-0128		US		1
K003	CONTACTOR	2- 90075-0126		US		1
	CONSISTS OF / SPARE PART					
	3- 90075-0313	AUXILIARY CONTACT		SP	UN	QTY
K006	RELAY	3- 90119-0056		UP		1
K006:1	BASE	3- 90129-0006		S		1
K006:2	CLAMP	1- 90119-0312		S		1
K014	CONTACTOR 4KW	2- 90075-0124		US		1
	CONSISTS OF / SPARE PART					
	3- 90075-0313	AUXILIARY CONTACT		SP	UN	QTY
K026	RELAY	3- 90119-0056		UP		1
K026:1	BASE	3- 90129-0006		S		1
K026:2	CLAMP	1- 90119-0312		S		1
K030	RELAY	3- 90119-0056		UP		1
K030:1	BASE	3- 90129-0006		S		1
K030:2	CLAMP	1- 90119-0312		S		1
K036	RELAY	3- 90119-0056		UP		1



POS	PART TITLE / REMARKS	PART NUMBER	R	SP	UN	QTY
K036:1	BASE	3-- 90129-0006	S			1
K036:2	CLAMP	90119-0312	S			1
K046	RELAY	3-- 90119-0056	UP			1
K046:1	BASE	3-- 90129-0006	S			1
K046:2	CLAMP	90119-0312	S			1
K048	CONTACTOR 4KW	2-- 90075-0124	US			1
	CONSISTS OF / SPARE PART					
	3-- 90075-0313	AUXILIARY CONTACT				
K051	CONTACTOR 4KW	2-- 90075-0124	US			1
	CONSISTS OF / SPARE PART					
	3-- 90075-0313	AUXILIARY CONTACT				
K052	RELAY	3-- 90119-0056	UP			1
K052:1	BASE	3-- 90129-0006	S			1
K052:2	CLAMP	90119-0312	S			1
K053	RELAY	3-- 90119-0056	UP			1
K053:1	BASE	3-- 90129-0006	S			1
K053:2	CLAMP	90119-0312	S			1
K054	RELAY	3-- 90119-0056	UP			1
K054:1	BASE	3-- 90129-0006	S			1
K054:2	CLAMP	90119-0312	S			1
K071	CONTACTOR 7,5KW	2-- 90075-0128	US			1
K075	CONTACTOR 7,5KW	2-- 90075-0125	US			1
	CONSISTS OF / SPARE PART					
	3-- 90075-0313	AUXILIARY CONTACT				
K077	CONTACTOR 7,5KW	2-- 90075-0125	US			1
	CONSISTS OF / SPARE PART					
	3-- 90075-0313	AUXILIARY CONTACT				
K081	CONTACTOR 4KW	2-- 90075-0124	US			1
	CONSISTS OF / SPARE PART					
	3-- 90075-0313	AUXILIARY CONTACT				
K082	CONTACTOR 4KW	2-- 90075-0124	US			1
	>>>>>> CONTINUES ON NEXT PAGE >>>>>>					



PDS	PART TITLE / REMARKS	PART NUMBER	R	SP	UN	QTY
	CONSISTS OF / SPARE PART					
	3-- 90075-0313 AUXILIARY CONTACT					
K083	RELAY	3-- 90119-0056	UP			1
K083:1	BASE	3-- 90129-0006	S			1
K083:2	CLAMP	90119-0312	S			1
K084	RELAY	3-- 90119-0056	US			1
K084:1	BASE	3-- 90129-0006	S			1
K084:2	CLAMP	90119-0312	S			1
K087	CONTACTOR 7.5KW	2-- 90075-0125	US			1
	CONSISTS OF / SPARE PART					
	3-- 90075-0313 AUXILIARY CONTACT					
K088	CONTACTOR 7.5KW	2-- 90075-0125	US			1
	CONSISTS OF / SPARE PART					
	3-- 90075-0313 AUXILIARY CONTACT					
K091	CONTACTOR 7.5KW	2-- 90075-0125	US			1
	CONSISTS OF / SPARE PART					
	3-- 90075-0313 AUXILIARY CONTACT					
K092	CONTACTOR 4KW	2-- 90075-0127	US			1
K093	CONTACTOR 4KW	2-- 90075-0124	US			1
	CONSISTS OF / SPARE PART					
	3-- 90075-0313 AUXILIARY CONTACT					
K094	CONTACTOR 4KW	2-- 90075-0124	US			1
	CONSISTS OF / SPARE PART					
	3-- 90075-0313 AUXILIARY CONTACT					
K095	RELAY	3-- 90119-0056	UP			1
K095:1	BASE	3-- 90129-0006	S			1
K095:2	CLAMP	90119-0312	S			1
K096	CONTACTOR 7.5KW	2-- 90075-0128	US			1
K097	RELAY	3-- 90119-0056	UP			1
K097:1	BASE	3-- 90129-0006	S			1
K097:2	CLAMP	90119-0312	S			1



POS	PART TITLE / REMARKS	PART NUMBER	R	SF	LN	QTY
K098	CONTACTOR 7.5KW	2-- 90075-0125	US		1	1
	CONSISTS OF / SPARE PART			SF	LN	QTY
	3-- 90075-0313 AUXILIARY CONTACT					
K099	CONTACTOR 4KW	2-- 90075-0124	US		1	1
	CONSISTS OF / SPARE PART			SF	LN	QTY
	3-- 90075-0313 AUXILIARY CONTACT					
K105	SOLID-STATE RELAY	3-- 90119-0067	UP		1	1
K106	SOLID-STATE RELAY	3-- 90119-0067	UP		1	1
K108	SOLID-STATE RELAY	3-- 90119-0067	UP		1	1
K110	OPTO SWITCH	3-- 90119-0043	UP		1	1
K111	SOLID-STATE RELAY	3-- 90119-0067	UP		1	1
K112	SOLID-STATE RELAY	3-- 90119-0067	UP		1	1
K113	SOLID-STATE RELAY	3-- 90119-0067	UP		1	1
K114	SOLID-STATE RELAY	3-- 90119-0067	UP		1	1
K201	CONTACTOR 4KW	2-- 90075-0124	US		1	1
	CONSISTS OF / SPARE PART			SF	LN	QTY
	3-- 90075-0313 AUXILIARY CONTACT					
K207	SOLID-STATE RELAY	3-- 90119-0067	UP		1	1
L001	BALLAST COIL 50/60HZ	90297-0306	S		1	1
L002	BALLAST COIL 50/60HZ	90297-0306	S		1	1
L004	BALLAST COIL 50/60HZ	90297-0306	S		1	1
M002	FAN	90264-0026	C		1	1
M002:1	COOLING ELEMENT	495201	C		1	1
M002:2	PIPE COUPLER 15-1/2"	342723-0114	C		1	1
F002	HOUR METER	90178-0007	S		1	1
F004	COUNTING APPARATUS	90053-0029	S		1	1
F004:1	SIGN PACKAGE COUNTER L 1"	359241-0199	C		1	1
F005	RECORDER 50HZ	90332-0007	C		1	1
	CONSISTS OF / SPARE PART			SF	LN	QTY
	4-- 90332-0308 KEY					
	90333-0004 GRAPH PAPER					
R001	SWITCH	2-- 90111-0135	C		1	1
R001:1	SIGN	359241-0124	C		1	1



PDS	PART TITLE / REMARKS	PART NUMBER	R	SP	LN	0101
R001:2	SIGN,VOLTAGE/FREQ./CURR,	4- 359241-0297	C		1	
R002	MOTOR SWITCH	2- 90259-0030	S		1	
R002:1	AUXILIARY CONTACT	3- 90259-0306	S		1	
R003	MOTOR SWITCH	3- 90259-0029	S		1	
R003:1	AUXILIARY CONTACT	3- 90259-0306	S		1	
R012	MOTOR SWITCH 1,6-2,4A	3- 90259-0023	S		1	
R051	MOTOR SWITCH 6-10A	3- 90259-0026	S		1	
R051:1	AUXILIARY CONTACT	3- 90259-0306	S		1	
R077	MOTOR SWITCH	3- 90259-0027	S		1	
R077:1	AUXILIARY CONTACT	3- 90259-0306	S		1	
R081	MOTOR SWITCH 2-4A	3- 90259-0024	S		1	
R081:1	AUXILIARY CONTACT	3- 90259-0306	S		1	
R082	MOTOR SWITCH 1-1,6A	3- 90259-0017	S		1	
R082:1	AUXILIARY CONTACT	3- 90259-0306	S		1	
R087	MOTOR SWITCH 6-10A	3- 90259-0026	S		1	
R087:1	AUXILIARY CONTACT	3- 90259-0306	S		1	
R091	MOTOR SWITCH 6-10A	3- 90259-0026	S		1	
R091:1	AUXILIARY CONTACT	3- 90259-0306	S		1	
R093	MOTOR SWITCH 1-1,6A	3- 90259-0017	S		1	
R094	MOTOR SWITCH	3- 90259-0021	S		1	
R094:1	AUXILIARY CONTACT	3- 90259-0306	S		1	
R098	MOTOR SWITCH 6-10A	3- 90259-0026	S		1	
R098:1	AUXILIARY CONTACT	3- 90259-0306	S		1	
R099	MOTOR SWITCH	3- 90259-0022	S		1	
R099:1	AUXILIARY CONTACT	3- 90259-0306	S		1	
R201	MOTOR SWITCH 1-1,6A	3- 90259-0017	S		1	
R201:1	AUXILIARY CONTACT	3- 90259-0306	S		1	
R003	POTENTIOMETER	90130-0017	S		1	
R003:1	KNOB	90130-0301	C		1	
R003:2	SIGN	359241-0261	C		1	
R004	POTENTIOMETER	90130-0017	S		1	
R004:1	KNOB	90130-0301	C		1	
R004:2	SIGN	359241-0260	C		1	
S002	SWITCH	3- 90111-0124	S		1	
S002:1	SIGN'CL.OF ST.BARRIER SP.	359241-0122	C		1	
S003	SWITCH UNIT	90023-0070	S		1	
S003:1	SIGN	359320-0002	C		1	



PDS	PART TITLE / REMARKS	PART NUMBER	R	SP	UN	0101
S004	KEY SWITCH	3-- 90111-0122	S		1	1
S004:1	SIGN"SERVICE SWITCH"	359241-0133	C		1	1
S032	EMERGENCY STOP	3-- 90064-0105	S		1	1
S032:1	SIGN	4-- 486826-0001	C		1	1
S034	PUSH BUTTON RED	3-- 90064-0085	S		1	1
S034:1	SIGN"SHORT STOP"	359301-0110	C		1	1
S034:2	TOUCH GUARD	90064-0317	C		1	1
T001	TRANSFORMER	2-- 90245-0019	C		1	1
T002	TRANSFORMER	3-- 23118	C		1	1
T009	TRANSFORMER	3-- 23139	C		1	1
V003	RECTIFIER	3-- 90038-0024	S		1	1
V010	FEED THROUGH LAMMA WTRU 2,5	3-- 353021-0122				
	* SEE TERMINAL DRWG: 571519					
V011	FEED THROUGH LAMMA WTRU 2,5	3-- 353021-0122				
	* SEE TERMINAL DRWG: 571519					
W406	CABLE	90220-0059	C	MM	5000	
W407	CABLE	90220-0059	C	MM	5000	
W408	CABLE	90220-0059	C	MM	5000	
W409	CABLE	90220-0059	C	MM	5000	
W410	CABLE	90220-0059	C	MM	5000	
W411	CABLE	90220-0059	C	MM	5000	
W412	CABLE	90220-0059	C	MM	5000	
W447	CABLE	90220-0036	C	MM	4000	
W448	CABLE	90220-0036	C	MM	4000	
W450	CABLE	90220-0059	C	MM	5000	
W604	CABLE	90220-0059	C	MM	5000	
XL01	TERMINAL DRAWING XL1-3	4-- 571525			1	
XL02	TERMINAL DRAWING XL1-3	4-- 571525				
XL03	TERMINAL DRAWING XL1-3	4-- 571525				
XL10	TERMINAL DRAWING XL, X009	4-- 571519			1	
XL11	TERMINAL DRAWING XL, X009	4-- 571519				
XL12	TERMINAL DRAWING XL, X009	4-- 571519				
XL20	TERMINAL DRAWING XL, X009	4-- 571519				
XL50	TERMINAL DRAWING XL, X009	4-- 571519				
XL51	TERMINAL DRAWING XL, X009	4-- 571519				



PDS	PART TITLE / REMARKS	PART NUMBER	R	SP	UN	0101
X001:1	TERMINAL DRWG X001, X011	4- 570926-0001	-	-	1	1
X001:2	TERMINAL DRAWING X001	4- 570926-0002	-	-	1	1
X001:3	TERMINAL DRAWING X001	4- 570926-0003	-	-	1	1
X001:4	TERMINAL DRAWING X001	4- 570926-0004	-	-	1	1
X003	TERMINAL DRAWING X003	4- 571518	-	-	1	1
X009	TERMINAL DRAWING XL, X009	4- 571519	-	-	-	-
X010	WALL SOCKET	3- 90001-0028	C	-	1	1
X011	TERMINAL DRWG X001, X011	4- 570926-0001	-	-	-	-
X016	STRIP	90077-0106	-	-	1	1
X017	CONTACT UNIT	90110-0028	C	-	1	1
X019	CONTACT UNIT	90110-0029	C	-	1	1
X021	TERMINAL BLOCK	90195-0010	C	-	1	1
X023	TERMINAL BLOCK	4- 90077-0102	C	-	1	1
X024	TERMINAL BLOCK	4- 90195-0020	C	-	1	1
0020	MACHINE PLATE	4- 27402	-	-	1	1
0030	SIGN HOLDER	2- 359240-0100	-	-	29	29
0040	SIGN IDENTIF. OF WIRING"	90194-0080	-	-	1	1
1 0045	SIGN WHITE CARD EL.EQ."	90194-0112	-	-	1	1
0050	FUSE PANEL LABEL	4- 571517	-	-	1	1
0060	SIGN, UNENGRAVED	4- 359240-0001	-	-	13	13
0070	CABLE GLAND ST 36	352103-0122	S	-	1	1
0080	BLANK-OFF PLUG	90002-0014	C	-	5	5
0090	BLANK-OFF PLUG 22,5	4- 90002-0004	C	-	1	1
0095	NUT	90099-0110	C	-	1	1
0100	GLAND FITT	352136-0142	C	-	3	3
0110	HOSE .022	352135-0109	C	MM	1500	1500
0120	SIGN FLASH SIGN"	90194-0016	C	-	1	1
0130	CABLE AWM ORANGE 0,75	351180-0102	C	MM	X	X
0140	CABLE AWM RED 0,75	351176-0102	C	MM	X	X
0150	CABLE AWM RED 4,0	351176-0106	C	MM	X	X
0160	CABLE AWM DARKBLUE 0,75	351172-0102	C	MM	X	X
0170	CABLE AWM DARKBLUE 4,0	351172-0106	C	MM	X	X
0180	CABLE AWM BLACK 1,5	351179-0104	C	MM	X	X
0190	CABLE AWM BLACK 2,5	351179-0105	C	MM	X	X
0200	CABLE AWM BLACK 6,0	351179-0107	C	MM	X	X
0210	CABLE AWM BLACK 25,0	351179-0110	C	MM	X	X
0220	CABLE AWM LIGHTBLUE 1,5	351173-0104	C	MM	X	X



BILL-OF-MATERIAL "0"

DATE PRINTED: 93-10-21

POS	PART TITLE / REMARKS	PART NUMBER	R	SP	UN	0101
0230	CABLE AWM LIGHTBLUE 2,5	351173-0105	C	MM		X
0240	CABLE AWM LIGHTBLUE 6,0	351173-0107	C	MM		X
0250	CABLE AWM LIGHTBLUE 25,0	351173-0110	C	MM		X
0260	CABLE AWM YELL/GREEN 0,75	351175-0102	C	MM		X
0270	CABLE AWM YELL/GREEN 1,5	351175-0104	C	MM		X
0280	CABLE AWM YELL/GREEN 2,5	351175-0105	C	MM		X
0290	CABLE AWM YELL/GREEN 4,0	351175-0106	C	MM		X
0300	CABLE AWM YELL/GREEN 6,0	351175-0107	C	MM		X
0310	CABLE AWM YELL/GREEN 16,0	351175-0109	C	MM		X

USED IN ASSEMB. 41729 649205

ECN NUMBER: EC 17786 EC 19260 EC 20555 FC 22852  
 DATE DISTRIBUTED 93-01-19 93-03-17 94-09-19 95-10-18

POS PART TITLE / REMARKS PART NUMBER R SP UN O101

MOUNTING DRAWING. PANEL 4- 52471-12:01 X  
 MOUNTING DRAWING. PANEL 3- 52471-13:01 X  
 MOUNTING DRAWING. PANEL 3- 52471-14:01 X

A016:1 POTENTIOMETER C- 67062-0201 S 1  
 A016:2 SIGN.SCALE POTENTIOMETER 4- 479876 C 1  
 A100 CIRCUIT BOARD TBA/9-080V 1- 554063 C 1  
 A100:1 DISPLAY 1- 570133 C 1

\* CLICHC NO: 251012

PL01 TERMINAL PLINTH 3- 90025-0029 S 1  
 PL02 TERMINAL PLINTH 3- 90025-0029 S 1  
 PL03 TERMINAL PLINTH 3- 90025-0029 S 1  
 PL04 TERMINAL PLINTH 3- 90025-0029 S 1  
 PL05 TERMINAL PLINTH 3- 90025-0030 S 1  
 PL06 TERMINAL PLINTH 3- 90025-0031 S 1  
 PX01 TERMINAL BLOCK P.X1. P.X2 4- 571520 - 1  
 PX02 TERMINAL BLOCK P.X1. P.X2 4- 571520 - 1  
 P003 COUNTER 90053-0024 S 1  
 P003:1 FRAME 90053-0305 S 1  
 P100 PROGRAM CARD 1- 90025-0042 S 1  
 S001 EMERGENCY STOP 3- 90064-0105 S 1  
 REPLACED BY

3- 90064-0124 EMERGENCY STOP BUTTON ECN 19692

S001:1 SIGN "EMERGENCY STOP" 4- 486826-0001 S 1  
 S002H PUSH BUTTON"GREEN" 3- 90064-0093 S 1  
 CONSISTS OF / SPARE PART SP UN QTY  
 90036-0057 LIGHT BULB BA9S 28V P 1

S002H1 SIGN "INCHING" 359301-0090 S 1



BILL-OF-MATERIAL "O"

DATE PRINTED: 95-10-18

POS	PART TITLE / REMARKS	PART NUMBER	R	SP	UN	QTY
S002H2	LIGHT BULB BA9S 28V	90036-0057	P			1
S003H	PUSH BUTTON "GREEN"	3- 90064-0093	S			1
	CONSISTS OF / SPARE PART					
	90036-0057 LIGHT BULB BA9S 28V		P			1
S003H1	SIGN "UP"	359301-0001	S			1
S003H2	LIGHT BULB BA9S 28V	90036-0057	P			1
S004H	PUSH BUTTON WHITE	3- 90064-0082	S			1
	CONSISTS OF / SPARE PART					
	90036-0057 LIGHT BULB BA9S 28V		P			1
S004H1	SIGN "DOWN"	359301-0005	S			1
S004H2	LIGHT BULB BA9S 28V	90036-0057	P			1
S006H	PUSH BUTTON RED	3- 90064-0085	S			1
S006H1	SIGN "SHORT STOP"	359301-0110	S			1
S006H2	LIGHT BULB BA9S 28V	90036-0057	P			1
S007	SWITCH 2 POS. EA OLTEN	3- 90111-0120	S			1
S011H	PUSH BUTTON CLEAR	3- 90064-0098	S			1
S011H1	SIGN "ALARM STOP"	359301-0105	S			1
S011H2	LIGHT BULB BA9S 28V	90036-0057	P			1
S012	PUSH BUTTON WHITE	3- 90064-0082	S			1
	CONSISTS OF / SPARE PART					
	90036-0057 LIGHT BULB BA9S 28V		P			1
S012:1	SIGN "LAMP TEST"	359301-0130	S			1
S019	PUSH BUTTON YELLOW	3- 90064-0084	S			1
S019:1	SIGN "DROP CHUTE"	359301-0050	S			1
S020	PUSH BUTTON YELLOW	3- 90064-0084	S			1
S020:1	SIGN "FINAL FOLDER"	359301-0170	S			1
I W017	CABLE OILFLEX 12X0.75	351150-0407	C	MM	1000	
Z001	INTERFERENCE PROTECTION	3- 276069	S			1
Z002	INTERFERENCE PROTECTION	3- 276069	S			1
0040	LAMP HOLDER BA9S	3- 90124-0027	S			20
0050	LIGHT BULB BA9S 28V	90036-0057	S			20
0060	SIGN "FLASH SIGN" 50X50MM	90194-0016	C			1



GENERAL REMARKS: THE FOLLOWING CABLES ARE PRE-WIRED COMPONENT CABLES: 0010, 0011, 0012, 0015, 0102, 0103, 0104, 0105, 0106, 0107, 0201, 0202, 0203, 0204, 0307, 0313, 0314, 0315, 0332, 0333, 0334, 0353, 0414, 0415, 0421, 0422, 0423, 0424, 0433, 0435, 0440, 0443, 0447, 0448, 0451, 0454, 0455, 0456, 0607, 0608, 0609, 0611

\*

\*

CABLE 0001-0026 BELONG TO BODY.  
 CABLE 0101-0199 BELONG TO DRIVING UNIT.  
 CABLE 0201-0299 BELONG TO FINAL FOLDER UNIT.  
 CABLE 0301-0399 BELONG TO SERVICE UNIT.  
 CABLE 0401-0499 BELONG TO SUPERSTRUCTURE.  
 CABLE 0601-0699 BELONG TO STRIP APPLICATOR.

USED IN ASSEMB. 41729 649205

ECN NUMBER: EC 19260 EC 20080 EC 20720  
 DATE DISTRIBUTED 93-03-17 93-09-15 93-12-02

PDS	PART TITLE / REMARKS	PART NUMBER	R	SF	UN	0101
0001	CABLE AWM BLACK 25,0	351179-0110	C	MM	5800	
0002	CABLE AWM BLACK 25,0	351179-0110	C	MM	5800	
0003	CABLE AWM BLACK 25,0	351179-0110	C	MM	5800	
0004	CABLE AWM BLACK 25,0	351179-0110	C	MM	5800	
0005	CABLE OILFLEX 462,5	351150-0418	C	MM	6600	
0006	CABLE OILFLEX 361,5	351150-0412	C	MM	3800	
0007	CABLE OILFLEX 361,5	351150-0412	C	MM	3200	
0008	CABLE OILFLEX N2X0,75	351150-0122	C	MM	5500	
0013	CABLE OILFLEX N2X0,75	351150-0122	C	MM	900	
0017	CABLE OILFLEX 1660,75	351150-0408	C	MM	4700	
0018	DATA CABLE	90220-0073	C	MM	5300	
0019	CABLE OILFLEX 361,5	351150-0412	C	MM	4550	
0022	CABLE OILFLEX 462,5	351150-0418	C	MM	2600	
0023	CABLE OILFLEX 462,5	351150-0418	C	MM	6700	
0025	CABLE OILFLEX 2760,75	351150-0409	C	MM	6700	
0026	CABLE OILFLEX N2X0,75	351150-0122	C	MM	4550	
0101	CABLE OILFLEX 762,5	351150-0420	C	MM	3250	
0108	CABLE OILFLEX 2760,75	351150-0409	C	MM	3550	



POS	PART TITLE / REMARKS	PART NUMBER	R	SF	UN	Q101
0302	CABLE	SIHF 362,5	C	MM	5000	
0304	CABLE	OILFLEX 462,5	C	MM	6600	
0305	CABLE	OILFLEX 362,5	C	MM	5500	
0306	CABLE	OILFLEX 462,5	C	MM	6550	
0308	CABLE	OILFLEX 462,5	C	MM	2500	
0309	CABLE	OILFLEX 1260,75	C	MM	4700	
0310	CABLE	OILFLEX 760,75	C	MM	6550	
0311	CABLE	OILFLEX N2X0,75	C	MM	4950	
0316	CABLE	OILFLEX 360,75	C	MM	4600	
0317	CABLE	OILFLEX 360,75	C	MM	4700	
0319	CABLE	OILFLEX N2X0,75	C	MM	4500	
0320	CABLE	OILFLEX N2X0,75	C	MM	4100	
0321	CABLE	OILFLEX N2X0,75	C	MM	4300	
0322	CABLE	OILFLEX 360,75	C	MM	4100	
0325	CABLE	OILFLEX N2X0,75	C	MM	4000	
0335	CABLE AWM YELL/GREEN 1,6,0	351175-0109	C	MM	1000	
0336	CABLE AWM YELL/GREEN 4,0	351175-0106	C	MM	3400	
0342	CABLE	OILFLEX N2X0,75	C	MM	4300	
0345	CABLE	OILFLEX N2X0,75	C	MM	4100	
0348	CABLE	OILFLEX N2X0,75	C	MM	3900	
0351	CABLE	OILFLEX 361,5	C	MM	5700	
0352	CABLE	OILFLEX N2X0,75	C	MM	4200	
0354	CABLE	OILFLEX 360,75	C	MM	4400	
0355	CABLE	OILFLEX 460,75	C	MM	5550	
0356	CABLE	OILFLEX 460,75	C	MM	6000	
0358	CABLE	OILFLEX 360,75	C	MM	900	
0360	CABLE	OILFLEX 460,75	C	MM	2750	
0361	CABLE	OILFLEX 360,75	C	MM	2850	
0370	COAXIAL CABLE L= 2500 MM	4- 551969-0004	--		1	
0371	COAXIAL CABLE L= 2500 MM	4- 551969-0004	--		1	
0372	COAXIAL CABLE L= 600 MM	4- 548770-0008	--		1	
0373	COAXIAL CABLE L= 600 MM	4- 548770-0008	--		1	
0401	CABLE	SIHF 466	C	MM	5250	
0402	CABLE	SIHF 362,5	C	MM	4700	
0403	CABLE	SIHF 362,5	C	MM	5400	
0404	CABLE	OILFLEX 562,5	C	MM	5600	
0405	CABLE	OILFLEX 462,5	C	MM	4200	



FDS	PART TITLE / REMARKS	PART NUMBER	R	SP	LN	Q101
0406	CABLE	90220-0059	C	MM	5700	
0407	CABLE	90220-0059	C	MM	5800	
0408	CABLE	90220-0059	C	MM	5000	
0409	CABLE	90220-0059	C	MM	5700	
0410	CABLE	90220-0059	C	MM	4500	
0411	CABLE	90220-0059	C	MM	5350	
0412	CABLE	90220-0059	C	MM	5150	
0413	CABLE	351150-0411	C	MM	4250	
0416	OILFLEX 5260,75	351150-0122	C	MM	2000	
0417	OILFLEX N2X0,75	351150-0122	C	MM	3000	
0418	OILFLEX N2X0,75	351150-0122	C	MM	3000	
0425	OILFLEX 460,75	351150-0404	C	MM	3100	
0427	OILFLEX N2X0,75	351150-0122	C	MM	1800	
0428	OILFLEX N2X0,75	351150-0122	C	MM	1600	
0430	OILFLEX 360,75	351150-0403	C	MM	3000	
0431	OILFLEX 360,75	351150-0403	C	MM	3100	
0432	OILFLEX 360,75	351150-0403	C	MM	3000	
0434	OILFLEX 560,75	351150-0405	C	MM	2600	
0442	OILFLEX 462,5	351150-0418	C	MM	4100	
0444	OILFLEX N2X0,75	351150-0122	C	MM	2500	
0450	CABLE	90220-0059	C	MM	4550	
0452	CABLE	351120-0168	C	MM	2500	
0601	CABLE	351120-0145	C	MM	5500	
0602	CABLE	351120-0145	C	MM	5550	
0603	CABLE	351150-0418	C	MM	5300	
0604	CABLE	90220-0059	C	MM	5300	
0605	CABLE	351150-0405	C	MM	6100	
0606	CABLE	351150-0407	C	MM	4100	
0612	CABLE	351150-0122	C	MM	2400	



BILL-OF-MATERIAL

DATE PRINTED: 94-05-03

USED IN ASSEMBLY 41729 649205

ECN NUMBER: EC 19260 EC 20513  
DATE DISTRIBUTED 93-03-17 94-04-29

POS PART TITLE / REMARKS

PART NUMBER R W P UN QTY

0010 TPMC-DISCETTE 4- 47615-00:01 - 1

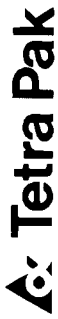

BILL-OF-MATERIAL "0"

DATE PRINTED: 94-05-03

USED IN ASSEMB. 41729 649205

ECN NUMBER: EC 19260 EC 20398 EC 20406 EC 20513  
DATE DISTRIBUTED 93-03-17 93-10-01 93-10-18 94-04-29

GROUP

VARIANT DESCRIP: -0101 400/230V, 60 HZ.  
-0102 ANY MAINVOLTAGE 50HZ. EXCEPT 400/230V.  
-0103 ANY MAINVOLTAGE 60HZ. EXCEPT 400/230V.  
-0104 ANY MAINVOLTAGE 60HZ.-USA- EXCEPT 400/230V.

POS PART TITLE / REMARKS PART NUMBER R SP UN 0101 0102 0103 0104

P005 RECORDER 60HZ 90332-0008 C 1 - 1 1  
CONSISTS OF / SPARE PART SP UN QTY  
4- 90332-0308 KEY  
90333-0004 GRAPH PAPER

P016 RECORDER 2- 90332-0015 S - - 1  
CONSISTS OF / SPARE PART SP UN QTY ECN  
4- 90332-0310 WRITING PAPER 17049  
4- 90332-0311 RIBBON CASSETTE 17049

Q001:3 SIGN.VOLTAGE/FREQ./CURR. 4- 359241-0298 C 1 - 1 1  
0010 TRANSFORMER 2- 90245-0024 C - 1 1 1

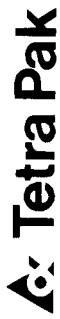

BILL-OF-MATERIAL "0"

DATE PRINTED: 94-05-03

USED IN ASSEMB. 41729 649205

ECN NUMBER: EC 19260 EC 20080 EC 20513  
DATE DISTRIBUTED 93-03-17 93-09-15 94-04-29

POS	PART TITLE / REMARKS	PART NUMBER	R	SP	UN	Q101
0010	LIGHT BULB BA9S 28V	90036-0057	-			10
0020	CONTACTOR 4KW	2- 90075-0127	-			1
0030	CONTACTOR 7.5KW	2- 90075-0128	-			1
0040	AUXILIARY CONTACT	3- 90075-0313	-			1
0050	RELAY	3- 90119-0056	-			1
0060	TOOL	90064-0315	-			1
0070	SOLID-STATE RELAY	3- 90119-0067	-			1
0080	PUSH BUTTON YELLOW	3- 90064-0084	-			1
0090	TUBE FUSE	90233-0009	-			5
0100	TUBE FUSE	90233-0019	-			5
0120	FUSE 16A	4- 90233-0027	-			5
0130	FUSE 10A	4- 90233-0028	-			5
0140	FUSE 25A	4- 90233-0029	-			5
0150	GRAPH PAPER	90333-0004	-			5
0160	PADLOCK	779910-0101	-			1

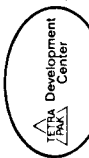

USED IN ASSEMB. 649205

ECN NUMBER: EC 17260 EC 20080  
DATE DISTRIBUTED 93-03-17 93-09-15

PDS	PART TITLE / REMARKS	PART NUMBER	R SF	ON	Q101
0010	CTRL CAB. TBA/9-1401 S.A.	CE- 41723-0101	-	1	1
0020	CTRL.PAN. TBA/9-1401 S.A.	CE- 41724-0101	-	1	1
0030	MACHINE	CE- 41725-0101	-	1	1
0040	EQUIPMENT TBA/9-1401 S.A.	CE- 41726-0101	-	1	1
0050	EXTRA EMU TBA/9-1401 S.A.	CE- 41727-0101	-	1	1
0060	SP. PARTS TBA/9-1401 S.A.	CE- 41728-0101	-	1	1
0070	EL-EQUIPMENT TPIH	CE- 41766-0101	-	1	1
0102	POSITION SUMMARY	4- 44093-02:01	-	1	1
0105	CIRCUIT DIAGRAM	4- 44093-05:01	-	1	1
0106	CIRCUIT DIAGRAM	4- 44093-06:01	-	1	1
0107	CIRCUIT DIAGRAM	4- 44093-07:01	-	1	1
0108	CIRCUIT DIAGRAM	4- 44093-08:01	-	1	1
0110	CIRCUIT DIAGRAM	4- 44093-10:01	-	1	1
0111	CIRCUIT DIAGRAM	4- 44093-11:01	-	1	1
0112	CIRCUIT DIAGRAM	4- 44093-12:01	-	1	1
0113	CIRCUIT DIAGRAM	4- 44093-13:01	-	1	1
0114	CIRCUIT DIAGRAM	4- 44093-14:01	-	1	1
0116	CIRCUIT DIAGRAM	4- 44093-16:01	-	1	1
0117	CIRCUIT DIAGRAM	4- 44093-17:01	-	1	1
0118	CIRCUIT DIAGRAM	4- 44093-18:01	-	1	1
0119	CIRCUIT DIAGRAM	4- 44093-19:01	-	1	1
0120	CIRCUIT DIAGRAM	4- 44093-20:01	-	1	1
0121	CIRCUIT DIAGRAM	4- 44093-21:01	-	1	1
0124	CIRCUIT DIAGRAM	4- 44093-24:01	-	1	1
0125	CIRCUIT DIAGRAM	4- 44093-25:01	-	1	1
0126	CIRCUIT DIAGRAM	4- 44093-26:01	-	1	1
0127	CIRCUIT DIAGRAM	4- 44093-27:01	-	1	1
0129	CIRCUIT DIAGRAM	4- 44093-29:01	-	1	1
0130	CIRCUIT DIAGRAM	4- 44093-30:01	-	1	1
0131	CIRCUIT DIAGRAM	4- 44093-31:01	-	1	1
0132	CIRCUIT DIAGRAM	4- 44093-32:01	-	1	1



POS	PART TITLE / REMARKS	PART NUMBER	R	SP	UN	Q101
0134	CIRCUIT DIAGRAM	4- 44093-34:01	--			1
0135	CIRCUIT DIAGRAM	4- 44093-35:01	--			1
0136	CIRCUIT DIAGRAM	4- 44093-36:01	--			1
0137	CIRCUIT DIAGRAM	4- 44093-37:01	--			1
0138	CIRCUIT DIAGRAM	4- 44093-38:01	--			1
0139	CIRCUIT DIAGRAM	4- 44093-39:01	--			1
0140	CIRCUIT DIAGRAM	4- 44093-40:01	--			1
0141	CIRCUIT DIAGRAM	4- 44093-41:01	--			1
0142	CIRCUIT DIAGRAM	4- 44093-42:01	--			1
0143	CIRCUIT DIAGRAM	4- 44093-43:01	--			1
0144	CIRCUIT DIAGRAM	4- 44093-44:01	--			1
0145	CIRCUIT DIAGRAM	4- 44093-45:01	--			1
0146	CIRCUIT DIAGRAM	4- 44093-46:01	--			1
0157	CIRCUIT DIAGRAM	4- 44093-57:01	--			1
0158	CIRCUIT DIAGRAM	4- 44093-58:01	--			1
0161	CIRCUIT DIAGRAM	4- 44093-61:01	--			1
0162	CIRCUIT DIAGRAM	4- 44093-62:01	--			1
0163	CIRCUIT DIAGRAM	4- 44093-63:01	--			1
0164	CIRCUIT DIAGRAM	4- 44093-64:01	--			1
0165	CIRCUIT DIAGRAM	4- 44093-65:01	--			1
0166	CIRCUIT DIAGRAM	4- 44093-66:01	--			1
0167	CIRCUIT DIAGRAM	4- 44093-67:01	--			1
0168	CIRCUIT DIAGRAM	4- 44093-68:01	--			1
0169	CIRCUIT DIAGRAM	4- 44093-69:01	--			1
0170	CIRCUIT DIAGRAM	4- 44093-70:01	--			1
0171	CIRCUIT DIAGRAM	4- 44093-71:01	--			1
0172	CIRCUIT DIAGRAM	4- 44093-72:01	--			1
0185	CIRCUIT DIAGRAM	4- 44093-85:01	--			1
0186	CIRCUIT DIAGRAM	4- 44093-86:01	--			1
0187	CIRCUIT DIAGRAM	4- 44093-87:01	--			1
0188	CIRCUIT DIAGRAM	4- 44093-88:01	--			1
0189	EARTH SUMMARY	4- 44093-89:01	--			1
0190	LINE SUMMARY	4- 44093-90:01	--			1
0191	TERMINAL SUMMARY	4- 44093-91:01	--			1
0199	ALTERATION MESSAGES	4- 44093-99:01	--			1
0301	TPMC LIST OF BLOCKS	4- 47615-01:01	--			1
0302	TPMC LIST OF ADDRESSES	4- 47615-02:01	--			1



FOS	PART TITLE / REMARKS	PART NUMBER	R	SP	UN	Q101
0303	VOLUME ADAPTION DOCUMENT	4- 47615-03:01	--			1
0304	TPMC SEQUENCE DIAGRAM	4- 47615-04:01	--			1
0305	TPMC PROGRAM LIST	4- 47615-05:01	--			1
0306	TPMC PROGRAM LIST	4- 47615-06:01	--			1
0307	TPMC PROGRAM LIST	4- 47615-07:01	--			1
0308	TPMC PROGRAM LIST	4- 47615-08:01	--			1
0309	TPMC PROGRAM LIST	4- 47615-09:01	--			1
0310	TPMC PROGRAM LIST	4- 47615-10:01	--			1
0311	TPMC PROGRAM LIST	4- 47615-11:01	--			1
0312	TPMC PROGRAM LIST	4- 47615-12:01	--			1
0313	TPMC PROGRAM LIST	4- 47615-13:01	--			1
0314	TPMC PROGRAM LIST	4- 47615-14:01	--			1
0317	TPMC PROGRAM LIST	4- 47615-17:01	--			1
0318	TPMC PROGRAM LIST	4- 47615-18:01	--			1
0319	TPMC PROGRAM LIST	4- 47615-19:01	--			1
0320	TPMC PROGRAM LIST	4- 47615-20:01	--			1
0323	TPMC PROGRAM LIST	4- 47615-23:01	--			1
0324	TPMC PROGRAM LIST	4- 47615-24:01	--			1
0325	TPMC PROGRAM LIST	4- 47615-25:01	--			1
0326	TPMC PROGRAM LIST	4- 47615-26:01	--			1
0327	TPMC PROGRAM LIST	4- 47615-27:01	--			1
0328	TPMC PROGRAM LIST	4- 47615-28:01	--			1
0329	TPMC PROGRAM LIST	4- 47615-29:01	--			1
0330	TPMC PROGRAM LIST	4- 47615-30:01	--			1
0331	TPMC PROGRAM LIST	4- 47615-31:01	--			1
0332	TPMC PROGRAM LIST	4- 47615-32:01	--			1
0333	TPMC PROGRAM LIST	4- 47615-33:01	--			1
0390	TPMC PROGRAM LIST	4- 47615-90:01	--			1
0399	TPMC PROGRAM LIST	4- 47615-99:01	--			1
0405	MOUNTING DRAWING, CABINET	4- 52471-05:01	--			1
0406	MOUNTING DRAWING, CABINET	4- 52471-06:01	--			1
0407	MOUNTING DRAWING, CABINET	4- 52471-07:01	--			1
0408	MOUNTING DRAWING, CABINET	4- 52471-08:01	--			1
0409	MOUNTING DRAWING, CABINET	4- 52471-09:01	--			1
0410	MOUNTING DRAWING, CABINET	4- 52471-10:01	--			1
0411	MOUNTING DRAWING, RACK	4- 52471-11:01	--			1
0412	MOUNTING DRAWING, PANEL	4- 52471-12:01	--			1



BILL-OF-MATERIAL "0"

DATE PRINTED: 93-10-26

PDS	PART TITLE / REMARKS	PART NUMBER	R	SF	UN	O101
0413	MOUNTING DRAWING, PANEL	3-- 52471-13:01	--			1
0414	MOUNTING DRAWING, PANEL	3-- 52471-14:01	--			1
0415	MOUNTING DRAWING, MACHINE	4-- 52471-15:01	--			1
0416	MOUNTING DRAWING, MACHINE	4-- 52471-16:01	--			1
0417	MOUNTING DRAWING, MACHINE	4-- 52471-17:01	--			1
0418	MOUNTING DRAWING, MACHINE	4-- 52471-18:01	--			1
0420	MOUNTING DRAWING, TPIH	4-- 52471-20:01	--			1
0421	MOUNTING DRAWING, TPIH	4-- 52471-21:01	--			1
0422	MOUNTING DRAWING, TPIH	4-- 52471-22:01	--			1
0423	MOUNTING DRAWING, TPIH	4-- 52471-23:01	--			1
0424	MOUNTING DRAWING, TPIH	4-- 52471-24:01	--			1
0425	MOUNTING DRAWING, TPIH	4-- 52471-25:01	--			1
0605	CONNECTION DRAWING	4-- 61232-05:01	--			1
0606	CONNECTION DRAWING	4-- 61232-06:01	--			1
0607	CONNECTION DRAWING	4-- 61232-07:01	--			1
0608	CONNECTION DRAWING	4-- 61232-08:01	--			1
0609	CONNECTION DRAWING	4-- 61232-09:01	--			1
0610	CONNECTION DRAWING	4-- 61232-10:01	--			1
0612	CONNECTION DRAWING	4-- 61232-12:01	--			1
0613	CONNECTION DRAWING	4-- 61232-13:01	--			1
0614	CONNECTION DRAWING	4-- 61232-14:01	--			1
0615	CONNECTION DRAWING	4-- 61232-15:01	--			1
0616	CONNECTION DRAWING	4-- 61232-16:01	--			1
0617	CONNECTION DRAWING	4-- 61232-17:01	--			1
0618	CONNECTION DRAWING	4-- 61232-18:01	--			1
0619	CONNECTION DRAWING	4-- 61232-19:01	--			1
0620	CONNECTION DRAWING	4-- 61232-20:01	--			1
0621	CONNECTION DRAWING	4-- 61232-21:01	--			1
0622	CONNECTION DRAWING	4-- 61232-22:01	--			1
0623	CONNECTION DRAWING	4-- 61232-23:01	--			1
0624	CONNECTION DRAWING	4-- 61232-24:01	--			1
0625	CONNECTION DRAWING	4-- 61232-25:01	--			1
0627	CONNECTION DRAWING	4-- 61232-27:01	--			1
0628	CONNECTION DRAWING	4-- 61232-28:01	--			1
0629	CONNECTION DRAWING	4-- 61232-29:01	--			1
0630	CONNECTION DRAWING	4-- 61232-30:01	--			1
0631	CONNECTION DRAWING	4-- 61232-31:01	--			1



PDS	PART TITLE / REMARKS	PART NUMBER	R	SF	UN	O101
0632	CONNECTION DRAWING	4- 61232-32:01	-	-	1	1
0633	CONNECTION DRAWING	4- 61232-33:01	-	-	1	1
0634	CONNECTION DRAWING	4- 61232-34:01	-	-	1	1
0635	CONNECTION DRAWING	4- 61232-35:01	-	-	1	1
0636	CONNECTION DRAWING	4- 61232-36:01	-	-	1	1
0643	CONNECTION DRAWING	4- 61232-43:01	-	-	1	1
0644	CONNECTION DRAWING	4- 61232-44:01	-	-	1	1
0645	CONNECTION DRAWING	4- 61232-45:01	-	-	1	1
0646	CONNECTION DRAWING	4- 61232-46:01	-	-	1	1
0647	CONNECTION DRAWING	4- 61232-47:01	-	-	1	1
0648	CONNECTION DRAWING	4- 61232-48:01	-	-	1	1
0649	CONNECTION DRAWING	4- 61232-49:01	-	-	1	1
0705	MAINS CONNECTION	4- 61252-05:01	-	-	1	1
0706	MAINS CONNECTION	4- 61252-06:01	-	-	1	1
0800:1	TERMINAL DRWG X001, X011	4- 570926-0001	-	-	1	1
0800:2	TERMINAL DRAWING X001	4- 570926-0002	-	-	1	1
0800:3	TERMINAL DRAWING X001	4- 570926-0003	-	-	1	1
0800:4	TERMINAL DRAWING X001	4- 570926-0004	-	-	1	1
0801	TERMINAL DRAWING X003	4- 571518	-	-	1	1
0802	TERMINAL DRAWING XL, X009	4- 571519	-	-	1	1
0803	LABEL EL-MANUAL	4- 570929	-	-	1	1
0804	INDEX EL-MANUAL	4- 571516	-	-	1	1
0805	FUSE PANEL LABEL	4- 571517	-	-	1	1
0806	TERMINAL BLOCK P,X1, F,X2	4- 571520	-	-	1	1
0807	TERMINAL DRWG X100, TPIH	4- 571524	-	-	1	1
0808	TERMINAL DRAWING XL1-3	4- 571525	-	-	1	1



USED IN ASSEMB. 41729 41756 41763 649205

ECN NUMBER: EC 17786 EC 19260 EC 20080  
DATE DISTRIBUTED 93-01-19 93-03-17 93-09-15

POS	PART TITLE / REMARKS	PART NUMBER	R	SP	UN	0101
	MOUNTING DRAWING, TPIH	4- 52471-20:01				X
	MOUNTING DRAWING, TPIH	4- 52471-21:01				X
	MOUNTING DRAWING, TPIH	4- 52471-22:01				X
	MOUNTING DRAWING, TPIH	4- 52471-23:01				X
	MOUNTING DRAWING, TPIH	4- 52471-24:01				X
	MOUNTING DRAWING, TPIH	4- 52471-25:01				X
A401	TPIH 2000 GENERATOR	C- 67600-0501	C			1
A402	TPIH 2000 GENERATOR	C- 67600-0501	C			1
A401:1	CONTACT UNIT	90110-0121	C			2
A401:2	COVER	90110-0122	C			2
A401:3	SIGN	359241-0261	C			1
A401:4	SIGN HOLDER	2- 359240-0100	C			1
A402:1	CONTACT UNIT	90110-0121	C			2
A402:2	COVER	90110-0122	C			2
A402:3	SIGN	359241-0261	C			1
A402:4	SIGN HOLDER	2- 359240-0100	C			1
M001	FAN	90264-0025	C			1
W370	COAXIAL CABLE L= 1150 MM	4- 551969-0003	C			1
W371	COAXIAL CABLE L= 1150 MM	4- 551969-0003	C			1
X100	TERMINAL DRWG X100, TPIH	4- 571524	-			1
0010	SIGN"FLASH SIGN"	90194-0016	C			1
0020	BLANK-OFF PLUG 22.5	4- 90002-0004	C			1
0030	NUT	90099-0110	C			1
0040	GLAND FITT	352136-0142	C			3



POSITION SUMMARY "A"

Date: 93-03-17

Machine: 649205

ECN 19260 '0'  
19930317 HK

Position	Sheet	Position	Sheet	Position	Sheet	Position	Sheet	Position	Sheet	Position	Sheet
A001	11:01	A106	45:01	M.E010	37:01	M.E046	40:01	M.E001C	06:01		
A002	35:01	A106	46:01	M.E011	37:01	M.E047	40:01	E004	06:01		
A004	18:01	A108	17:01	M.E012	37:01	M.E048A	41:01	M.E011	32:01		
A006	18:01	A114	61:01	M.E013	24:01	M.E048E	41:01				
A009	19:01	A114	62:01	M.E014	06:01	M.E050	20:01	F001	06:01		
A010	19:01	A115	63:01	M.E015	37:01	M.E051	40:01	F003	32:01		
A013	20:01	A115	64:01	M.E016A	41:01	M.E053	40:01	F005	07:01		
A014	20:01	A116	65:01	M.E016B	41:01	M.E054	25:01	F008	07:01		
A015	24:01	A116	66:01	M.E018	41:01	M.E055	20:01	F010	08:01		
P.A016:1	88:01	A117	67:01	M.E020	45:01	M.E061	40:01	F017	11:01		
A016A	34:01	A117	68:01	M.E021A	37:01	M.E062	41:01	F019	16:01		
A016B	34:01	A118	17:01	M.E021B	37:01	M.E063	40:01	F028A	08:01		
A017	24:01	A120	69:01	M.E021C	37:01	M.E064	25:01	F028E	08:01		
A018	25:01	A120	70:01	M.E024	39:01	M.E071	45:01	F028C	08:01		
A019	25:01	A121	71:01	M.E025	39:01	M.E080A	34:01	F029A	08:01		
A022	26:01	A121	72:01	M.E030A	38:01	M.E080B	34:01	F029B	08:01		
A023	30:01	A128	17:01	M.E030B	38:01	M.E085	41:01	F029C	08:01		
A024	30:01	A202	21:01	M.E032	39:01	M.E092	45:01	F030	10:01		
A025	72:01	A401	14:01	M.E033	39:01	M.E094	45:01	F031	10:01		
A030	21:01	A402	14:01	M.E034	25:01	M.E095	26:01	F041A	07:01		
P.A100	17:01	A450	27:01	M.E035	40:01	M.E104	40:01	F041E	07:01		
A101	36:01	A451	27:01	M.E036	21:01	M.E108	37:01	F042A	07:01		
A102	37:01			M.E037A	19:01	M.E233	36:01	F042E	07:01		
A102	38:01	M.E001	36:01	M.E037B	19:01			F055A	16:01		
A103	39:01	M.E002	38:01	M.E038	18:01	C001	06:01	F055E	16:01		
A103	40:01	M.E004	21:01	M.E039	19:01			F055C	16:01		
A104	41:01	M.E003	38:01	M.E040	18:01	D108	17:01	F056A	14:01		
A104	42:01	M.E007	38:01	M.E043	24:01			F056B	14:01		
A105	43:01	M.E008	39:01	M.E044	39:01	M.E001A	06:01	F056C	14:01		
A105	44:01	M.E009	39:01	M.E045	41:01	M.E001B	06:01	F202	07:01		

Based on ECN: 19260

POSITION SUMMARY

4- 44093-02:01

Sheet: 1  
Cont: 2



POSITION SUMMARY "A"

Date: 93-03-17

Machine: 649205

ECN 19260 \*0\*  
19930317 HK

Position	Sheet	Position	Sheet	Position	Sheet	Position	Sheet	Position	Sheet
G100	17:01	K002	65:01	K099	65:01	M.M006	11:01	R091	37:01
		K003	35:01	K105	10:01	M.M007	10:01	R093	13:01
P.H00111	85:01	K006	66:01	K106	10:01	M.M010	11:01	R094	10:01
P.H00112	55:01	K014	63:01	K108	08:01	M.M012	12:01	R094	37:01
P.H00211	85:01	K026	66:01	K110	32:01	M.M013	11:01	R098	10:01
P.H00212	85:01	K030	66:01	K111	08:01	M.M014	10:01	R098	41:01
P.H0025	88:01	K036	32:01	K112	08:01	M.M016	10:01	R099	12:01
P.H00311	85:01	K046	66:01	K113	08:01	M.M017	12:01	R099	41:01
P.H00312	85:01	K048	65:01	K114	08:01			R201	12:01
P.H0035	88:01	K051	63:01	K201	32:01	P002	63:01	R201	37:01
P.H00411	85:01	K052	66:01	K207	07:01	P.P003	88:01		
P.H00412	86:01	K053	66:01			P004	72:01	M.R001	06:01
P.H0045	88:01	K054	67:01	L001	06:01	P005	06:01	R003	14:01
P.H00511	86:01	K071	65:01	M.L001	14:01			R004	14:01
P.H00512	86:01	K075	65:01	L002	06:01	R001	05:01	M.R005A	07:01
P.H00611	86:01	K077	63:01	M.L002	14:01	R002	05:01	M.R005B	07:01
P.H00612	86:01	K081	62:01	L004	06:01	R003	10:01	M.R005C	07:01
P.H0065	88:01	K082	63:01	P.L1	57:01	R003	37:01	M.R031	07:01
P.H00711	86:01	K083	67:01	P.L1	58:01	R012	16:01	M.R032	08:01
P.H00712	86:01	K084	67:01	P.L3	85:01	R051	12:01	M.R035	08:01
P.H00811	86:01	K087	62:01	P.L3	86:01	R051	37:01	M.R036	08:01
P.H00812	87:01	K088	65:01	P.L4	87:01	R077	12:01	M.R037	07:01
P.H00911	87:01	K091	63:01	P.L4	88:01	R077	37:01	M.R038	07:01
P.H00912	87:01	K092	65:01			R081	10:01	R110	32:01
P.H01011	87:01	K093	62:01	M.M.PLF	13:01	R081	37:01		
P.H01012	87:01	K094	62:01	M001	14:01	R082	11:01	P.S001	35:01
P.H0115	88:01	K095	67:01	M.M001	12:01	R082	37:01	S002	37:01
M.H031	32:01	K096	65:01	M002	06:01	R087	10:01	P.S002H	57:01
		K097	67:01	M.M004	11:01	R087	41:01	S003	40:01
P.I	17:01	K098	62:01	M.M005	10:01	R091	11:01	P.S003H	57:01

Based on ECN: 19260

POSITION SUMMARY

4- 44093-02:01

Sheet: 2  
Cont: 3



Machine: 649205

ECN 19260 \*0\*  
19930317 HK

Position	Sheet	Position	Sheet	Position	Sheet	Position	Sheet	Position	Sheet
S004	38:01	W407	18:01	M.Y021	61:01				
M.S004	35:01	W408	18:01	M.Y022	69:01				
P.S004H	57:01	W409	19:01	M.Y023	68:01				
P.S006H	57:01	W410	19:01	M.Y024	61:01				
P.S007	57:01	W411	20:01	M.Y025	68:01				
P.S011H	57:01	W412	20:01	M.Y026	61:01				
P.S012	57:01	W447	34:01	M.Y027	64:01				
M.S014	38:01	W448	34:01	M.Y029	69:01				
P.S019	58:01	W450	19:01	M.Y031	69:01				
P.S020	58:01	W604	21:01	M.Y032	62:01				
M.S028	06:01			M.Y033	70:01				
S032	35:01	M.X001	36:01	M.Y034	70:01				
M.S033	37:01	X010	06:01	M.Y035	70:01				
S034	37:01			M.Y039	70:01				
M.S035	37:01	M.Y001	62:01	M.Y041	70:01				
		M.Y002	69:01	M.Y042	71:01				
T001	16:01	M.Y003	69:01	M.Y043	71:01				
T002	07:01	M.Y004	70:01	M.Y051	68:01				
T009	07:01	M.Y005	69:01	M.Y063	71:01				
		M.Y006	69:01	M.Y086	68:01				
V003	16:01	M.Y007	69:01	M.Y092	71:01				
V010	32:01	M.Y008	68:01	M.Y102	62:01				
V011	32:01	M.Y009	68:01						
		M.Y012	64:01	P.Z001	17:01				
P.W017	34:01	M.Y013	64:01	P.Z002	57:01				
P.W017	35:01	M.Y014	64:01						
P.W017	57:01	M.Y017	68:01						
W370	14:01	M.Y018	61:01						
W371	14:01	M.Y019	68:01						
W406	21:01	M.Y020	61:01						

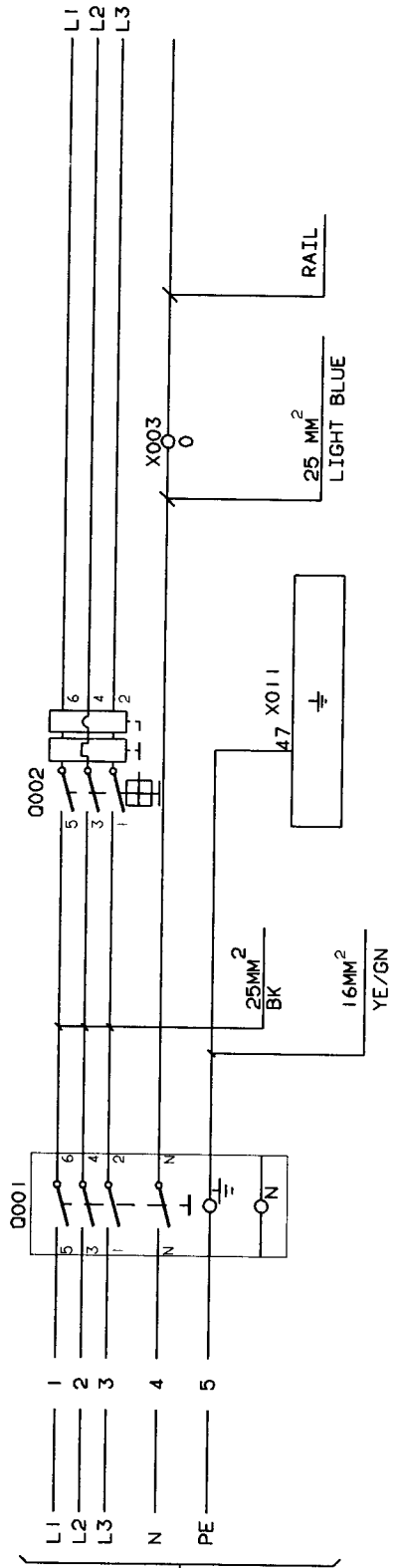

MAINS 400/230V  
FOR CONNECTION  
SEE DRAWING NO:  
61252-05:01

FOR TYPE OF WIRE, WIRING INSTRUCTIONS ETC.  
SEE SPECIFICATION FOR SUBSUPPLIERS TPUS 3502.22

WHERE NOTHING ELSE IS SAID: WIRE 0.75 mm<sup>2</sup> BU  
OR LINESUMMARY IS VALID

INTRODUCED WITH AM NO.	19260	DATE	930310	SIGN.	HK/UTH	DESCRIPTION:	MAINS CONNECTION	
TABLE								
AM NO.								
DATE								
SIGN.								
ALTERATIONS ONLY IN COLUMN							MACHINE:	TBA/9-1401 S.A
								44093-05:01

This drawing must not without the consent of Tetra Pak be copied, transmitted or disclosed to any third party.

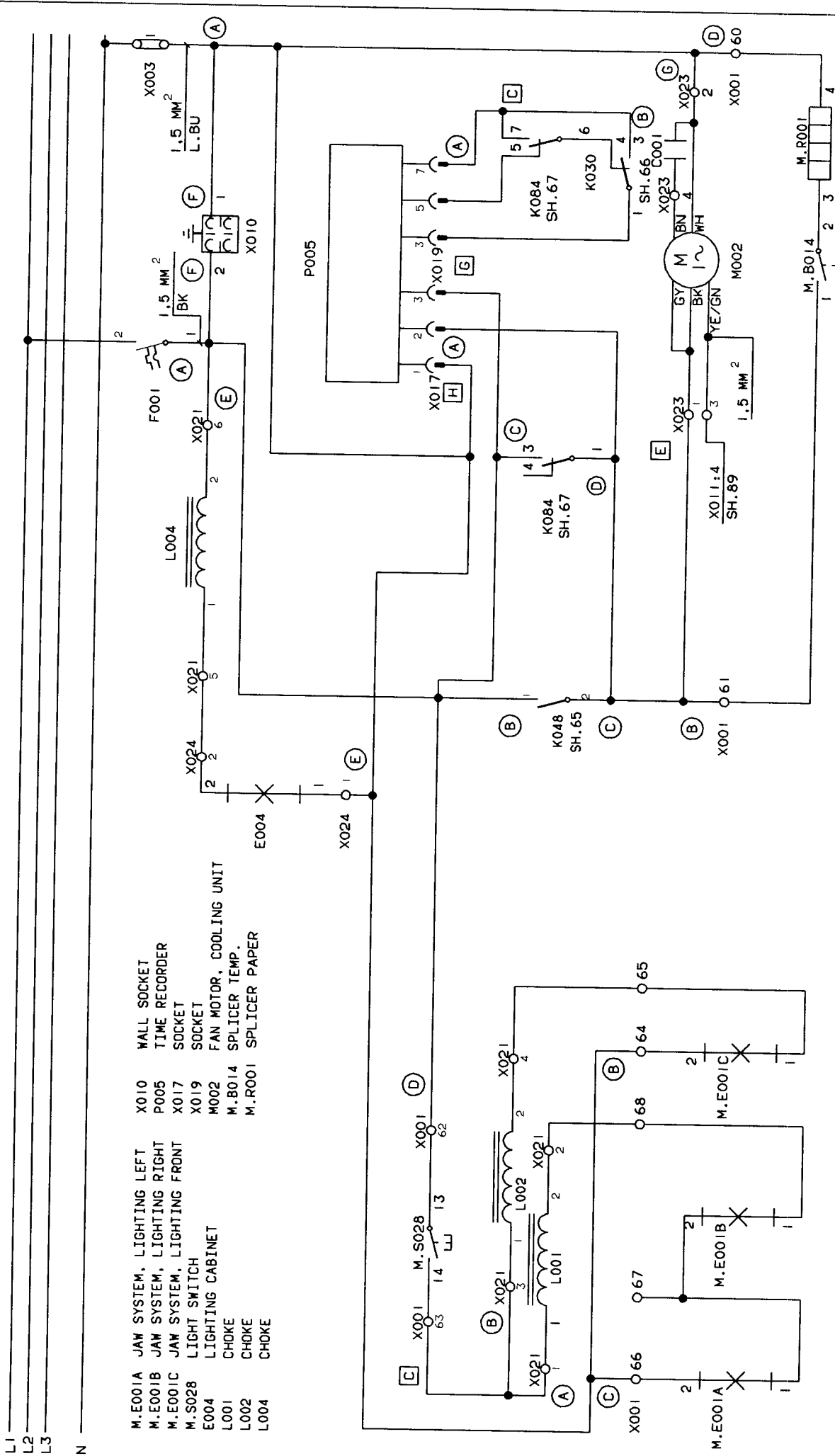

- |         |                            |        |                         |
|---------|----------------------------|--------|-------------------------|
| M.E001A | JAW SYSTEM, LIGHTING LEFT  | X010   | WALL SOCKET             |
| M.E001B | JAW SYSTEM, LIGHTING RIGHT | P005   | TIME RECORDER           |
| M.E001C | JAW SYSTEM, LIGHTING FRONT | X017   | SOCKET                  |
| M.S028  | LIGHT SWITCH               | X019   | SOCKET                  |
| E004    | LIGHTING CABINET           | M002   | FAN MOTOR, COOLING UNIT |
| L001    | CHOKE                      | M.B014 | SPLICER TEMP.           |
| L002    | CHOKE                      | M.R001 | SPLICER PAPER           |
| L004    | CHOKE                      |        |                         |

INTRODUCED BY: AM. NO.	19260	DATE:	930310	BY:	HK/UTH
TABLE					
AM. NO.					
DATE					
BY:					
ALTERATIONS ONLY IN CADAM					
DESCRIPTION: LIGHT FIXTURES, SPLICER				MACHINE: TBA/9-1401 S.A.	
				44093-06:01	

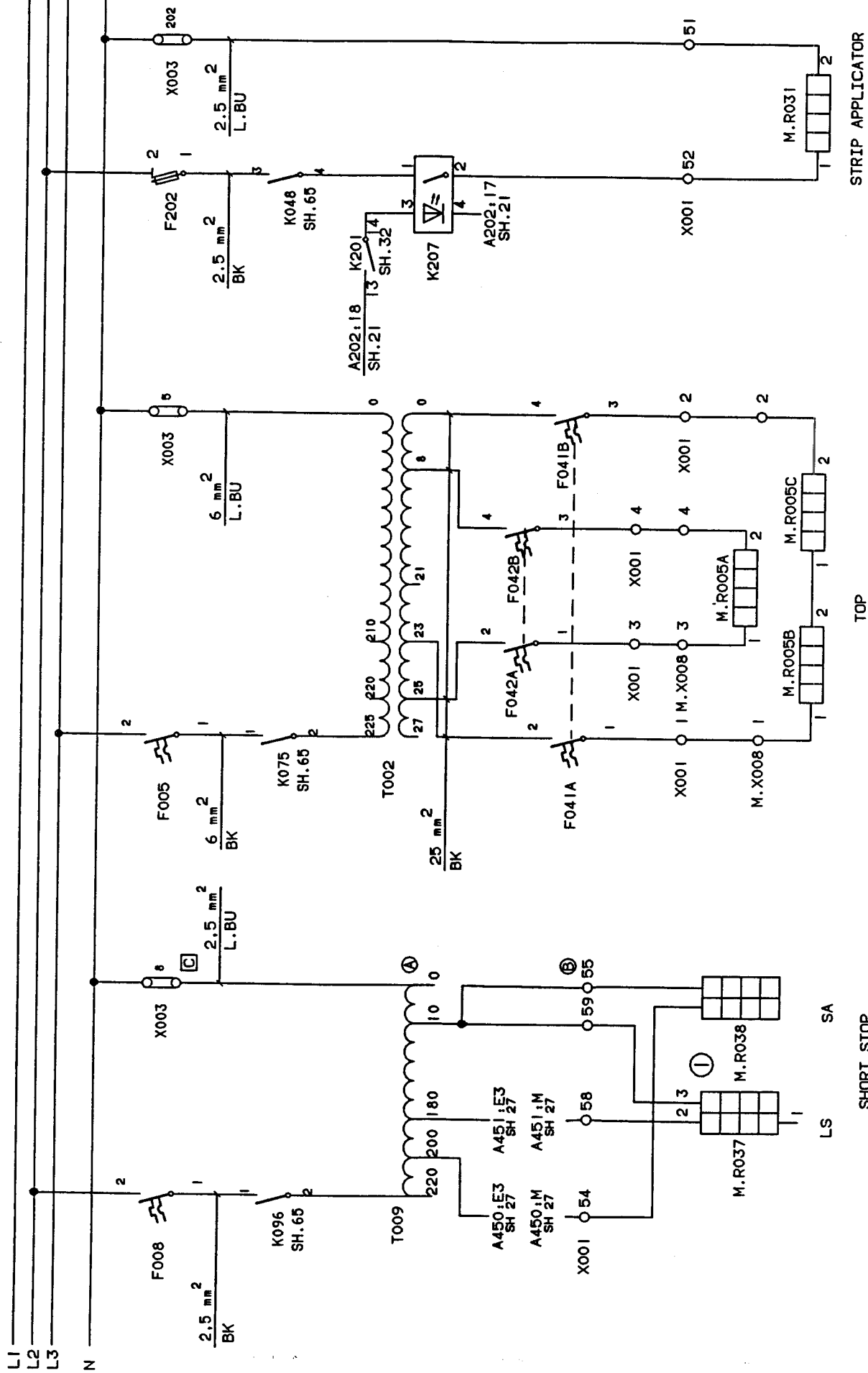

TOP  
FLAP SEALING

SHORT STOP  
LS SA

STRIP APPLICATOR

INTRODUCED WITH M/NO	DATE	930310	S10M	HK/UTH	ELEMENT PIN CONFIGURATION	DESCRIPTION	ELEMENTS	
A	19260				⊕			
B					⊕			
20080	20398				⊕	1-2= 1200W		
930909	930930				⊕	1-3= 700W		
HK/MRI	HK/MRI				⊕	2-3= 450W		
DRAWING REMARKS							MACHINE	TBA/9-1401 S.A.
								44093-07:01

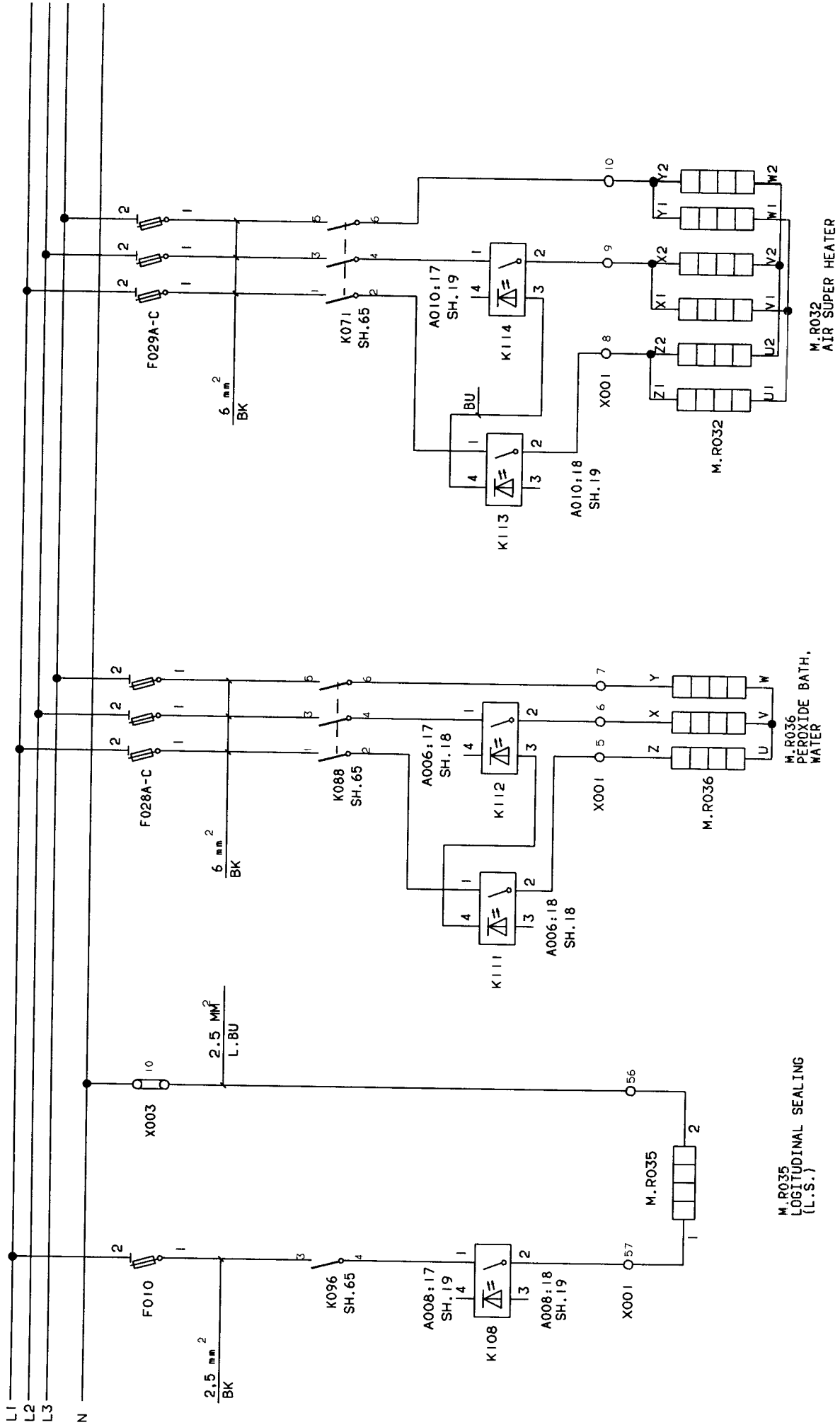

INTRODUCED BY: AM. NO.	19260	DATE:	930310	SIGN.	HK/UTH
TITLE					
AM. NO.					
DATE					
SIGN.					
ALTERATIONS ONLY IN CADAM					
DESCRIPTION:			ELEMENTS		
MACHINE:			TBA/9-1401 S.A		
			44093-08:01		

DRAWING REMARKS

This drawing must not without the consent of Tetra Pak, be copied, transmitted or disclosed to any third party.

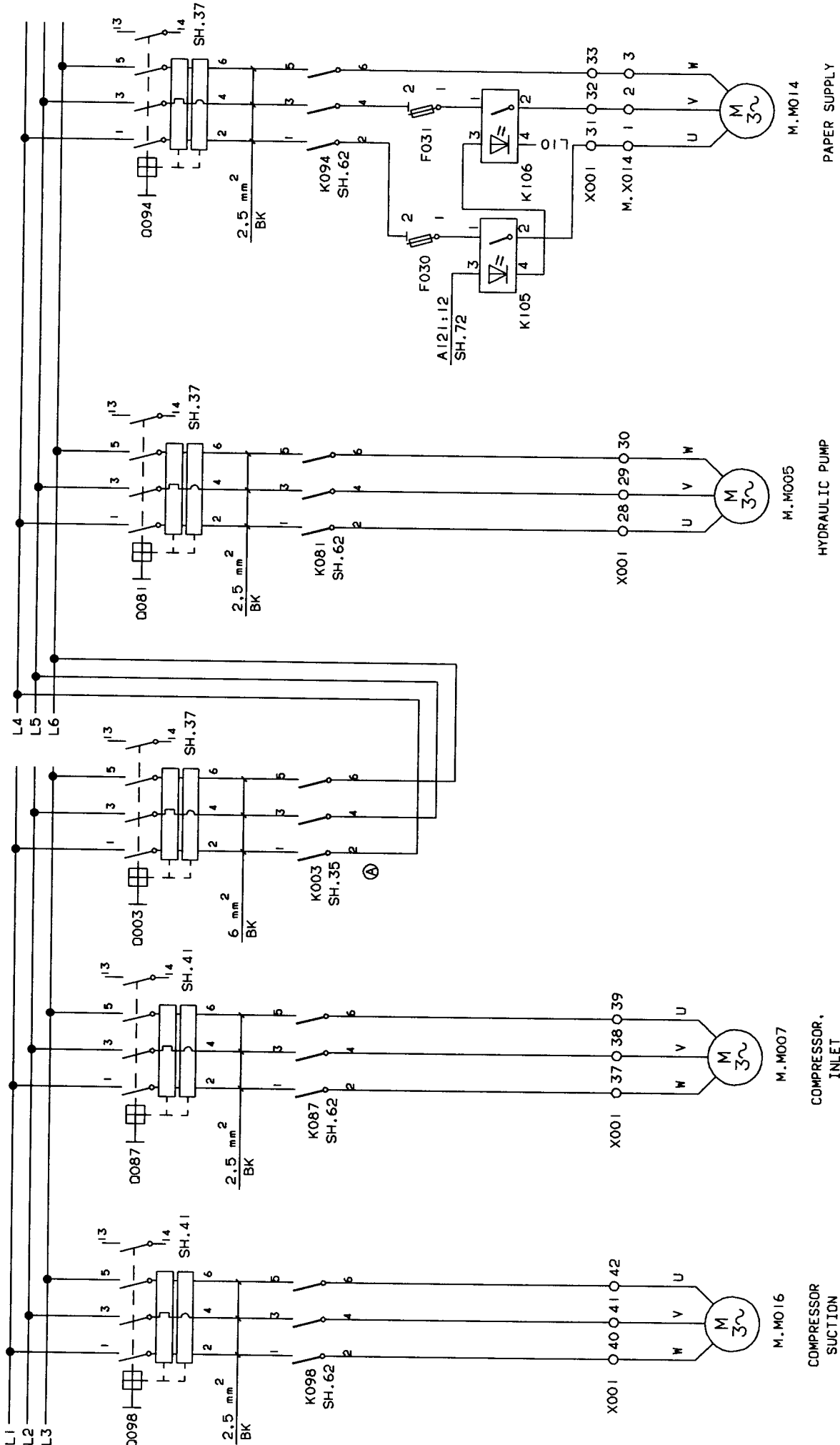

INTRODUCED WITH AM. NO.	19260	DATE	930310	STATION	HK/UTH
DRW. NO.	20080	DATE	930909	STATION	HK/MRI
DESCRIPTION	MOTORS				
MACHINE	TBA/9-1401 S.A				
ALTERATIONS ONLY IN CADAM	44093-10:01				

This drawing must not without the consent of Tetra Pak be copied, transmitted or disclosed to any third party.

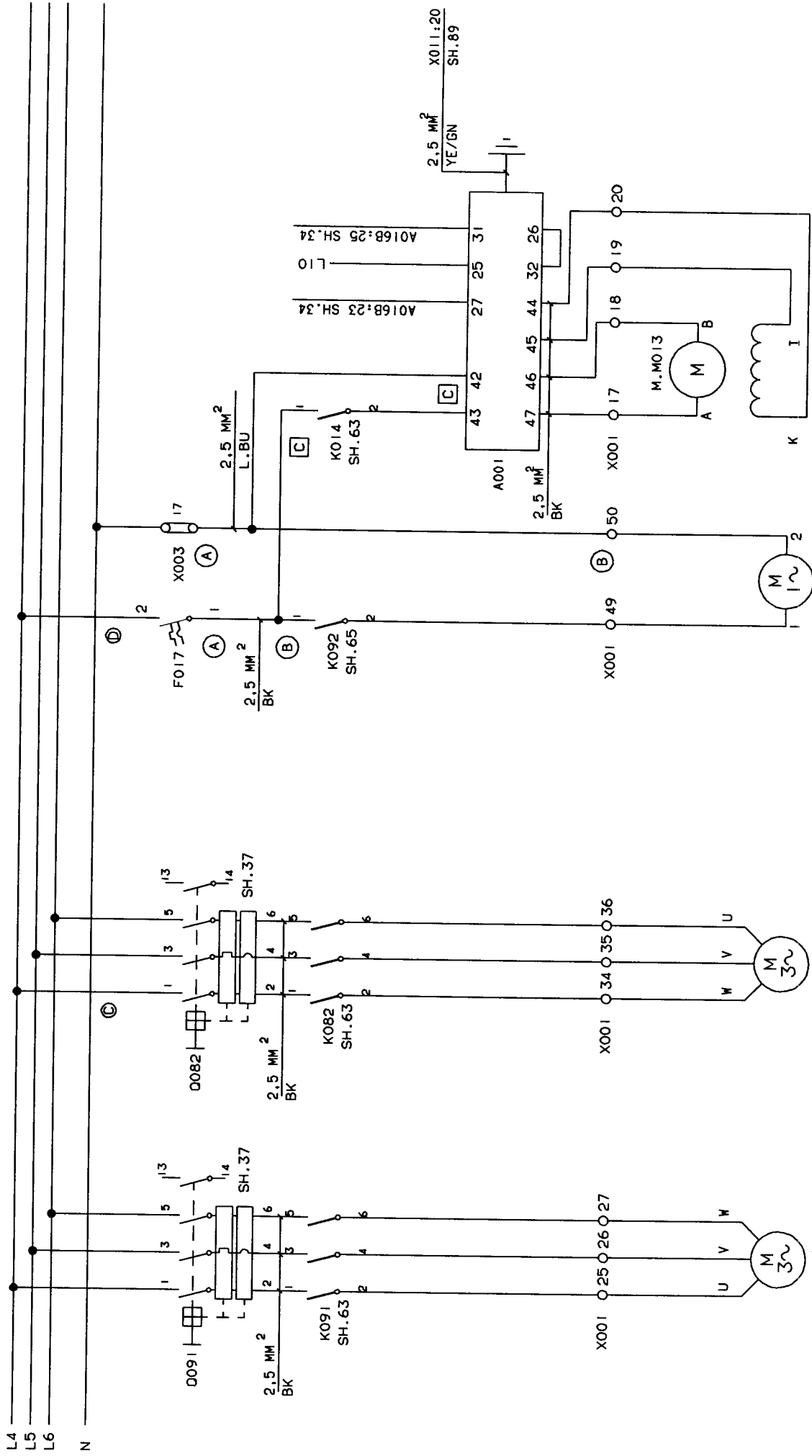

BENDING ROLLER  
M.M006  
DETERGENT PUMP

M.M004  
CLEANING SYSTEM,  
CIRCULATION PUMP

M.M010  
PEROXIDE PUMP

INTRODUCED WITH AM. NO.	19260	DATE	930310	STEP.	HK/UTH
TABLE NO.	20080	DATE	930909	STEP.	HK/MRI
ALTERATIONS ONLY IN CADAM					
DESCRIPTION:			MOTORS		
MACHINE:			TBA/9-1401 S.A.		
DRAWING REMARKS			44093-11:01		

This drawing must not without the consent of Tetra Pak be copied, transmitted or disclosed to any third party.

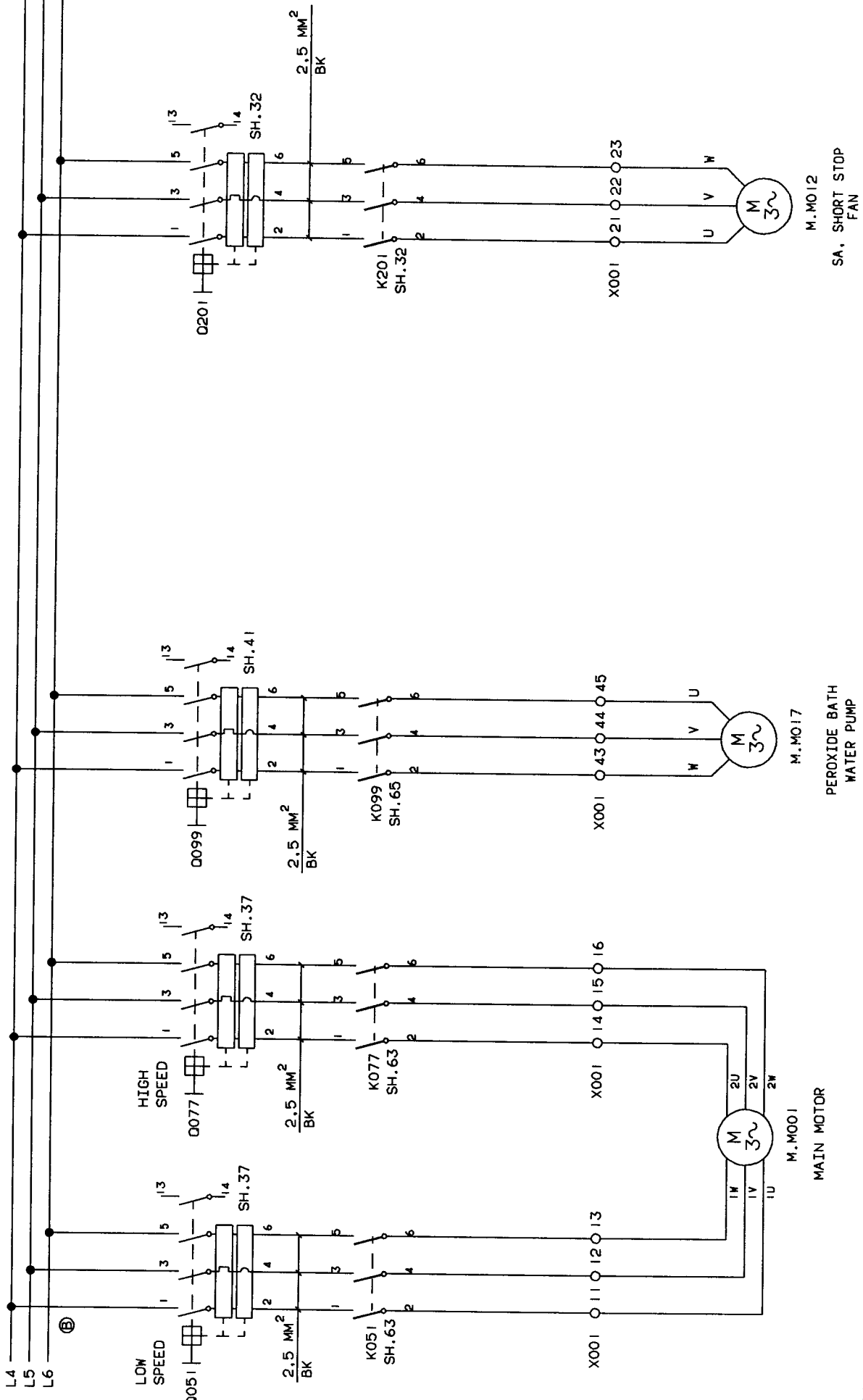

INTRODUCED WITH AM. NO.	19260	DATE	930310	SIGN.	HK/UTH
TABLE	A				
AM. NO.	20080				
DATE	930909				
SIGN.	HK/MRI				
ALTERATIONS ONLY IN CADAM					
DESCRIPTION:			MOTORS		
MACHINE:			TBA/9-1401 S.A		
			44093-12:01		

**Tetra Pak**  
LUND SWEDEN

This drawing must not without the consent of Tetra Pak be copied, transmitted or disclosed to any third party.

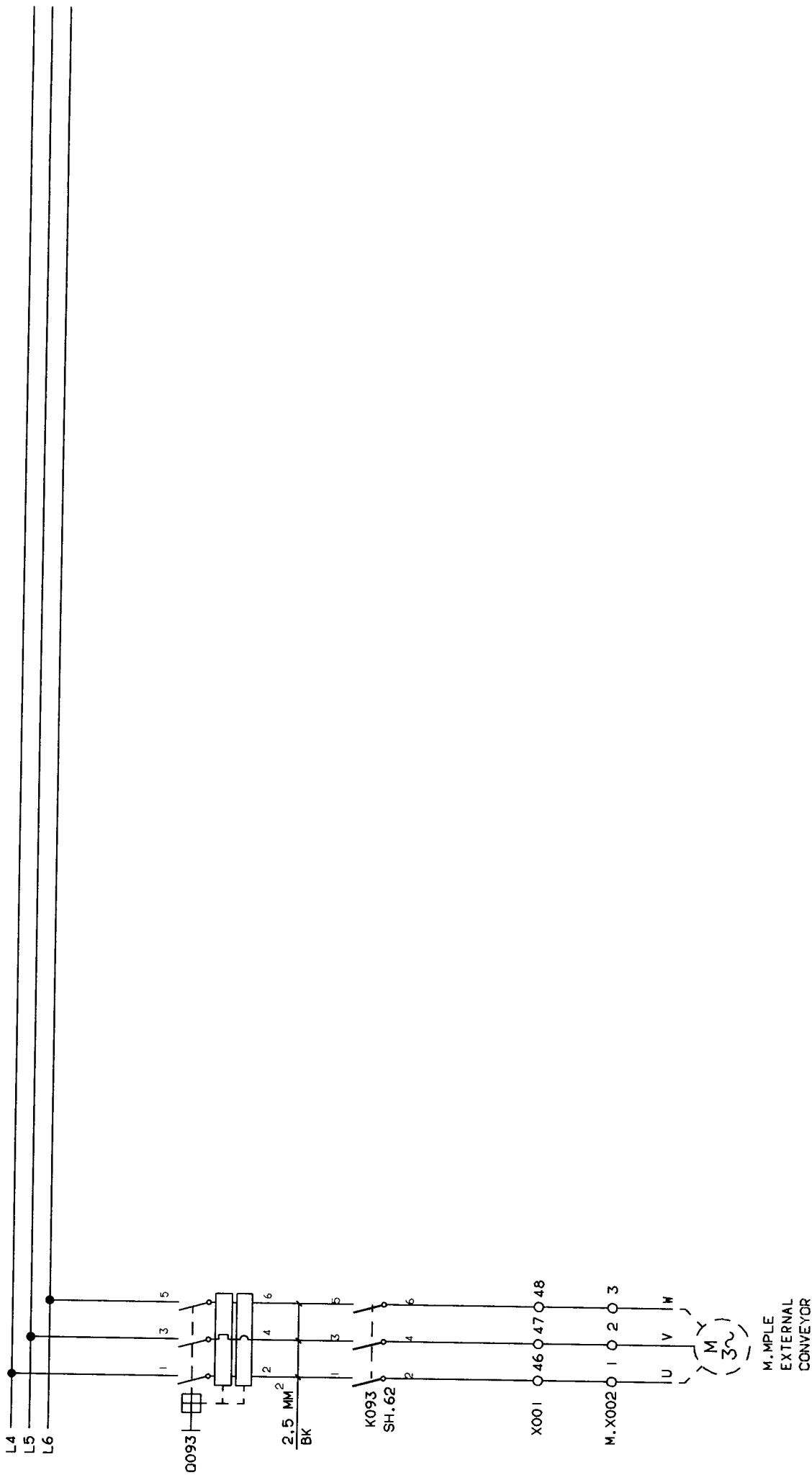

INTRODUCED WITH AM. NO.	DATE: 19260	SIGN. HK/LUTH	DESCRIPTION: MOTORS
ISSUE			
AM. NO.			
DATE			
SIGN.			
ALTERATIONS ONLY IN CADAM			MACHINE: TBA/9-1401 S.A
			44093-13:01

DRAWING REMARKS

This drawing must not without the consent of Tetra Pak be copied, transmitted or disclosed to any third party.

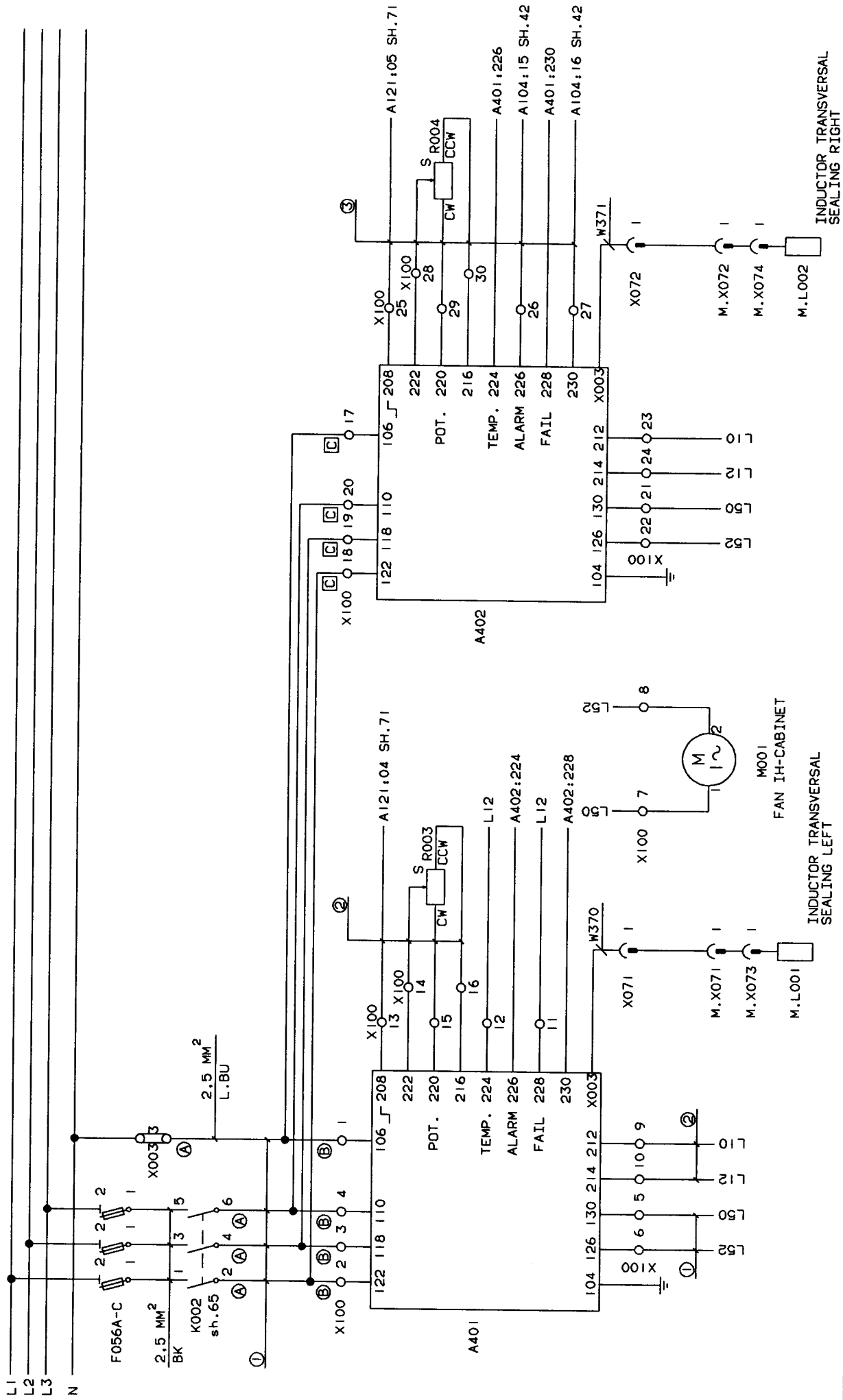

INTRODUCED WITH AM NO.	19260	DATE	930310	REV.	HK/UTH
TITLE	A				
APP NO	20080				
DATE	930909				
BY	HK/MPI				
ALTERATIONS ONLY IN CADAM					
				DESCRIPTION:	IH-GENERATOR
				MACHINE:	TBA/9-1401 S.A
					44093-14:01

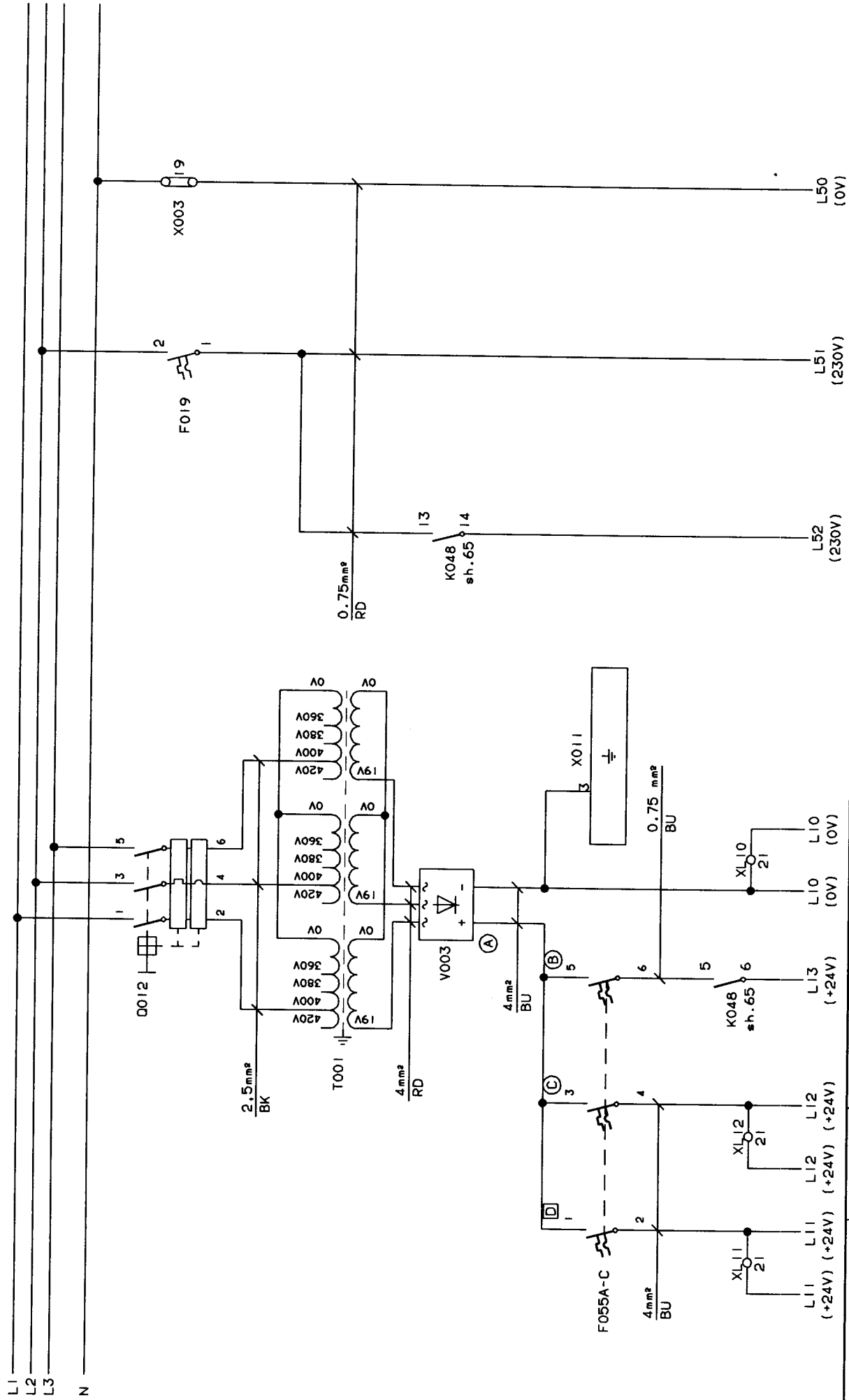

INTRODUCED WITH AM NO.	19260	DATE	930310	BY	HK/UTH
ISSUE	A	AM NO.	20080	DATE	930909
BY	HK/MPI	ALTERATIONS ONLY IN CADAM			
DESCRIPTION: CONTROL VOLTAGE					
MACHINE: TBA/9-1401 S.A					
44093-16:01					

This drawing must not without the consent of Tetra Pak be copied, transmitted or disclosed to any third party.

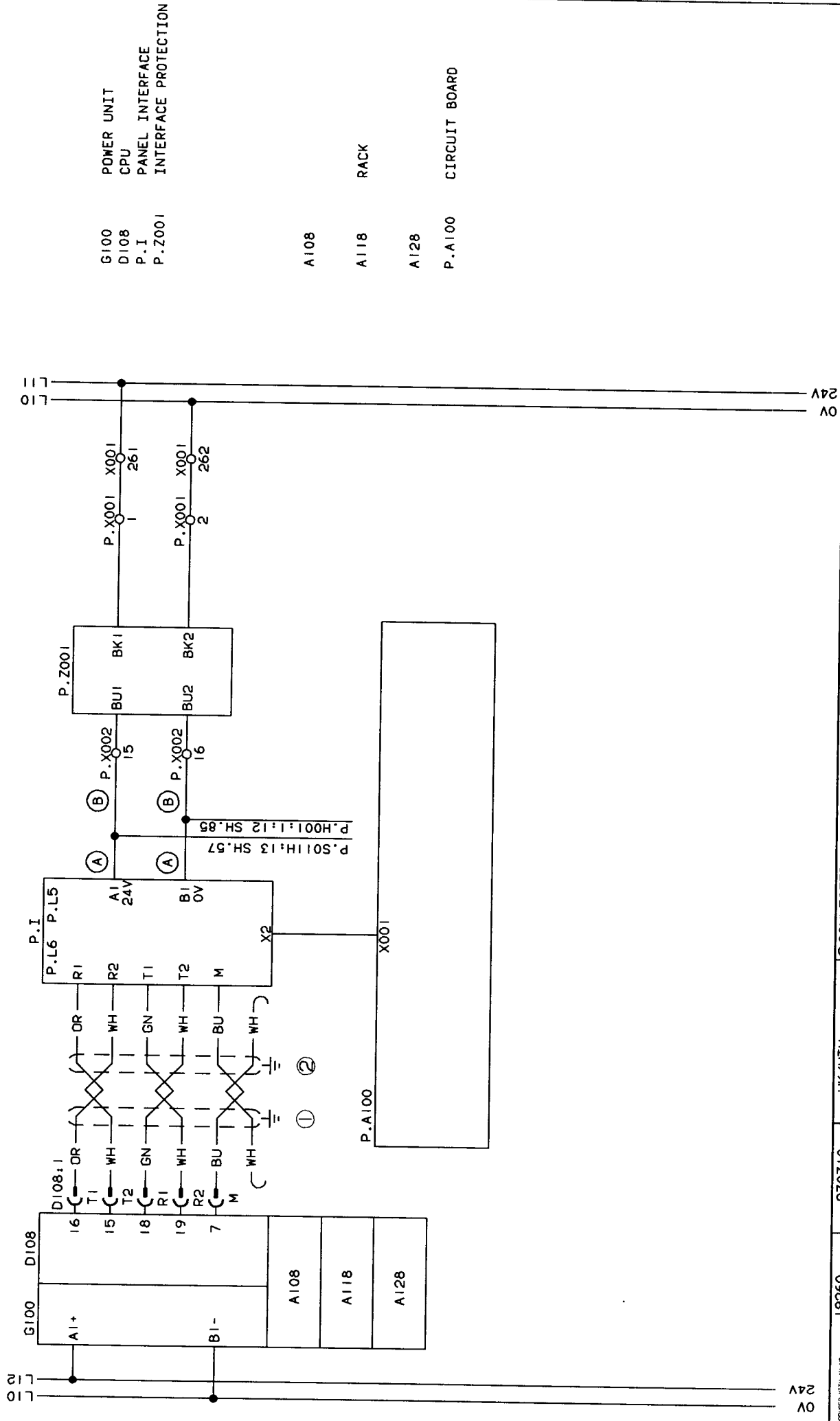

G100 POWER UNIT  
D108 CPU  
P.I PANEL INTERFACE  
P.Z001 INTERFACE PROTECTION

A108 RACK  
A118 RACK  
A128 RACK  
P.A100 CIRCUIT BOARD

INTRODUCED BY: AM 40	DATE: 19260	SIGN: HK/UTH	DESCRIPTION: TPMS
TABLE A	930310	① CONNECTED TO D-SUB COVER	
AM NO. 20080		② CONNECTED TO MOUNTINGPLATE NEAR INTERFERENCE PROT.	
DATE 930909			
SIGN HK/MRI			
ALTERATIONS ONLY IN CADAM			MACHINE: TBA/9-1401 S.A
			DRAWING REMARKS
			44093-17:01

This drawing must not without the consent of Tetra Pak be copied, transmitted or disclosed to any third party.

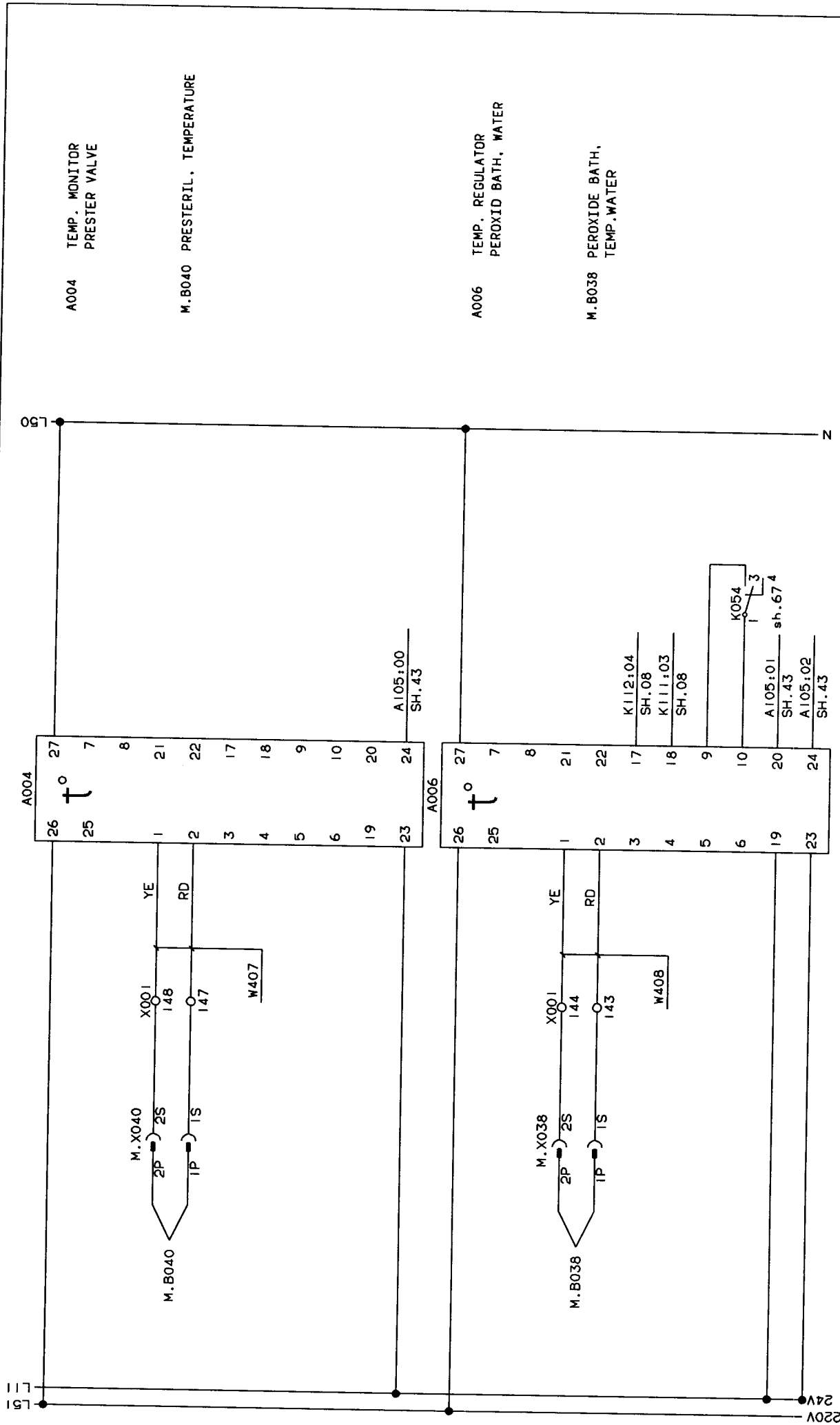

INTRODUCED WITH AM. NO.	DATE	930310	SIGN.	HK/JUTH
ISSUE				
AM. NO.				
DATE				
SIGN.				
ALTERNATIONS ONLY IN CADAM				
DRAWING REMARKS				
DESCRIPTION: REGULATORS				
MACHINE: TBA/9-1401 S.A				
44093-18:01				

This drawing must not without the consent of Tetra Pak be copied, transmitted or disclosed to any third party.

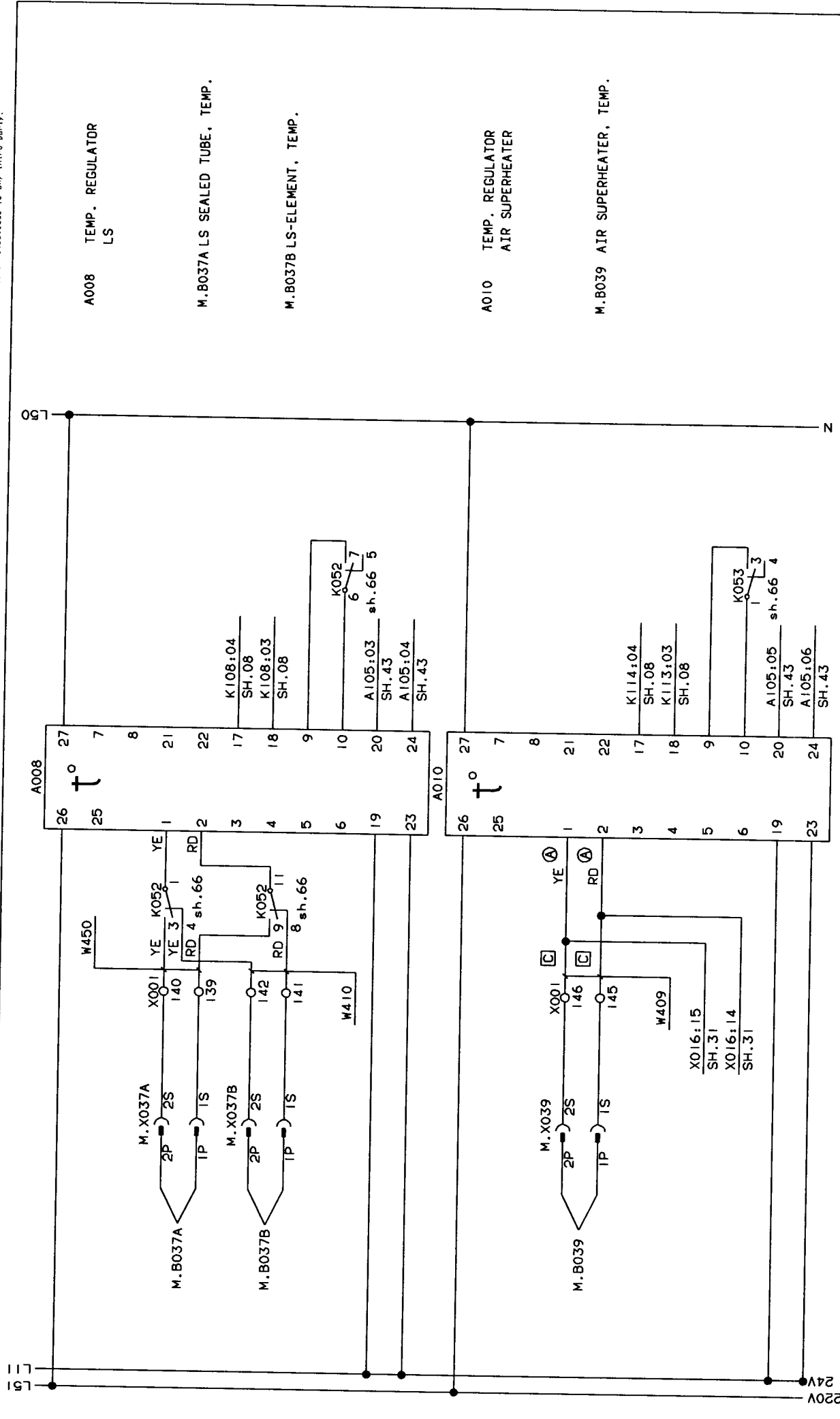

INTRODUCED BY: AM NO.	19260	DATE:	930310	BY:	HK/JUTH
TABLE					
AM NO.					
DATE					
BY					
ALTERNATIONS ONLY IN CADAM					
DRAWING REMARKS					
				DESCRIPTION:	REGULATORS
				MACHINE:	TBA/9-1401 S.A
					44093-19:01

This drawing must not without the consent of Tetra Pak be copied, transmitted or disclosed to any third party.

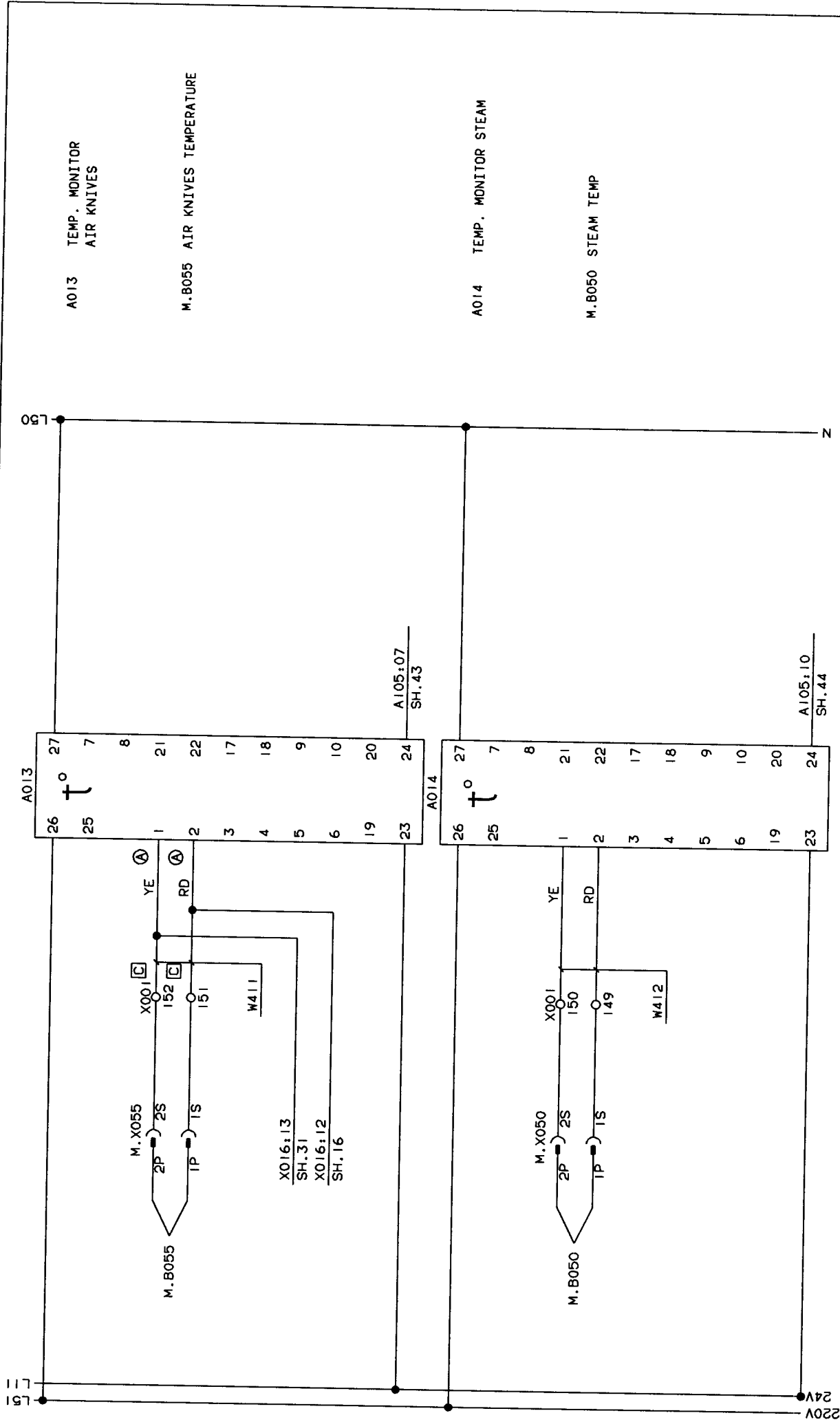

INTRODUCED WITH AM NO.	19260	DATE	930310	SUPP.	HK/LJTH
NAME					
AM NO.					
DATE					
SIGN.					
ALTERATIONS ONLY IN CADAM					
DESCRIPTION:			REGULATORS		
MACHINE:			TBA/9-1401 S.A		
DRAWING REMARKS			44093-20:01		

This drawing must not without the consent of Tetra Pak, be copied, transmitted or disclosed to any third party.

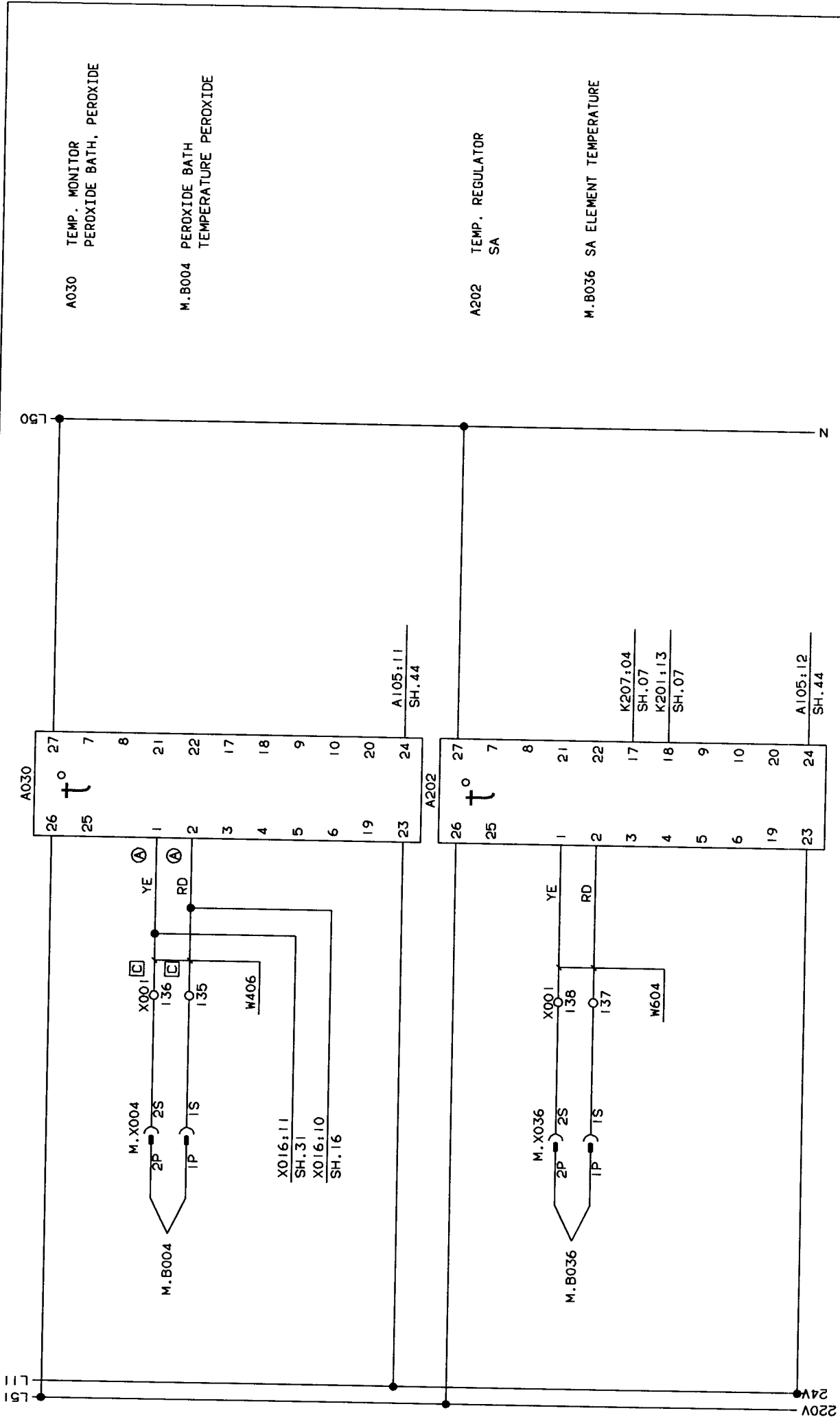

INTRODUCED WITH AM NO.	DATE	BY	CHK/UTH	DESCRIPTION:	MACHINE:
	19260	920325	HK/UTH	REGULATORS	TBA/9-1401 S.A
TITLE					
AM NO.					
DATE					
BY					
CHK					
DRAWING REMARKS					
ALTERATIONS ONLY IN CADAM					
					44093-21:01

This drawing must not without the consent of Tetra Pak be copied, transmitted or disclosed to any third party.

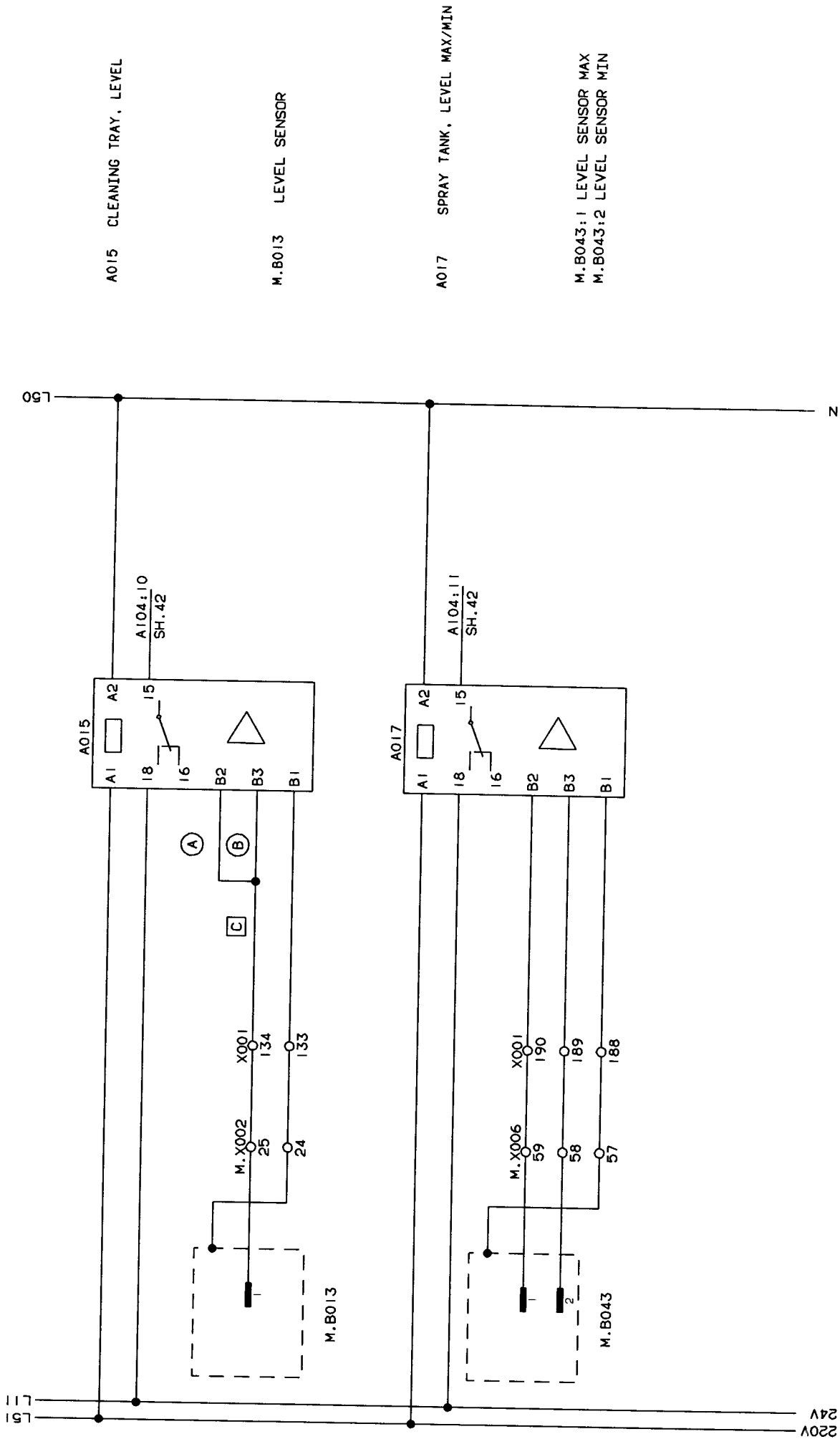

INTRODUCED WITH AM NO.	19260	DATE	930310	REV.	HK/UTH
TITLE					
AM NO.					
DATE					
REV.					
ALTERATIONS ONLY IN CADAM					
DESCRIPTION:				LEVEL MONITORS	
MACHINE:				TBA/9-1401 S.A	
				DRAWING REMARKS	
				44093-24:01	

This drawing must not without the consent of Tetra Pak be copied, transmitted or disclosed to any third party.

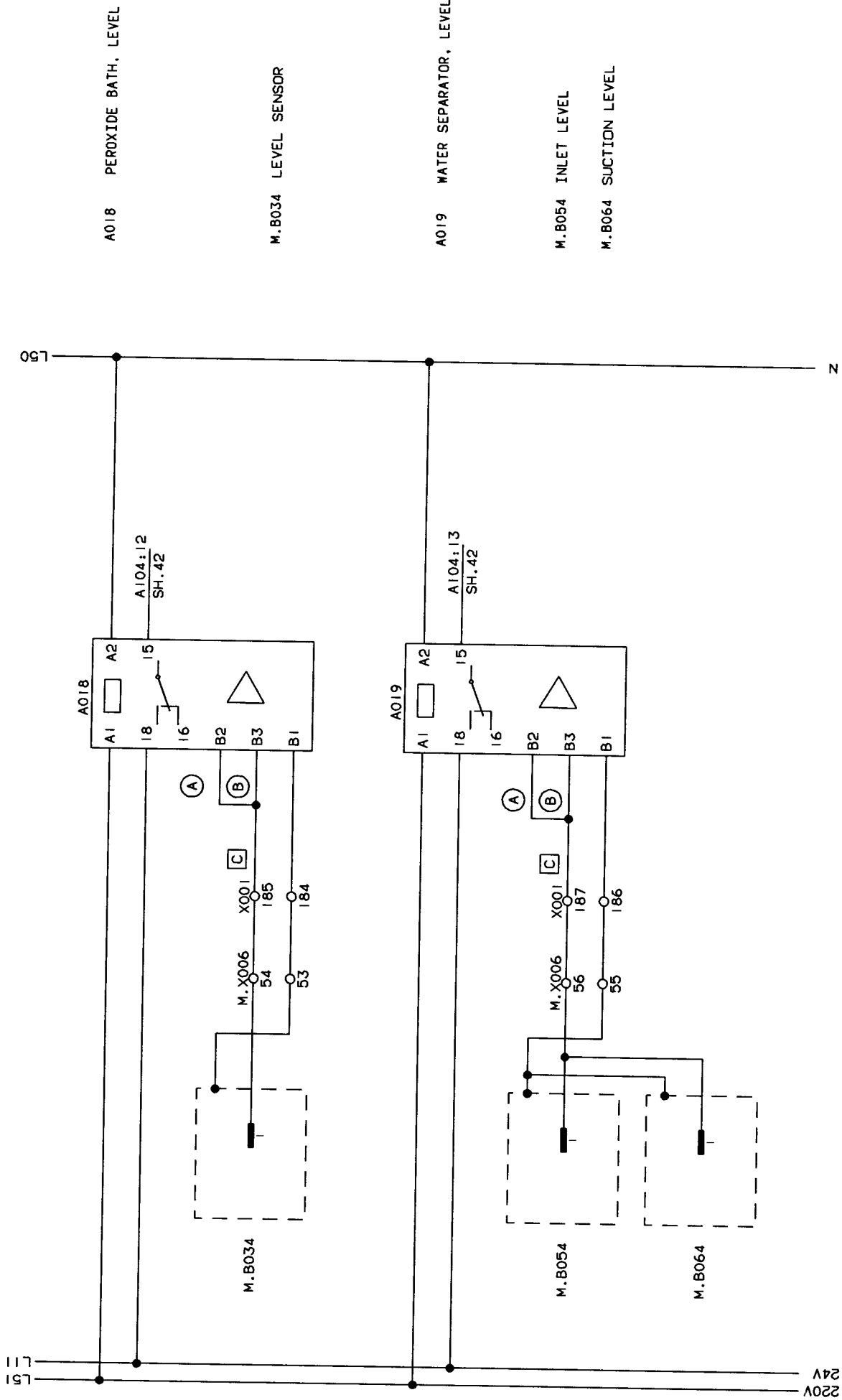

INTRODUCED WITH AM NO.	DATE	930310	SIGN.	HK/ZUTH
TITLE	AM NO.			
DATE				
SIGN.				
ALTERATIONS ONLY IN CADAM				
DESCRIPTION: LEVEL MONITORS			MACHINE: TBA/9-1401 S.A	
			44093-25:01	

This drawing must not without the consent of Tetra Pak be copied, transmitted or disclosed to any third party.

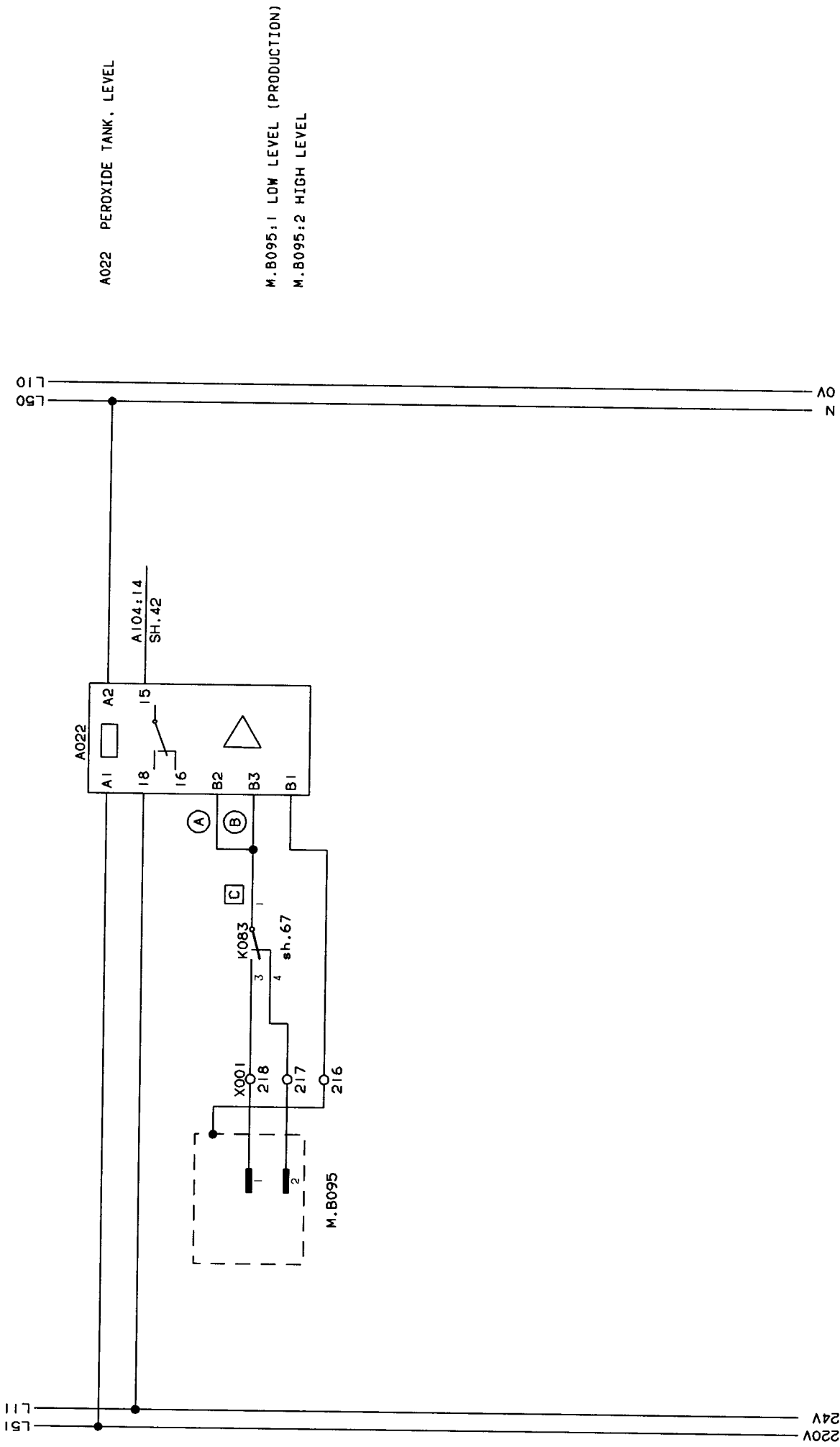

INTEGRATED WITH AM NO.	19260	DATE	930310	BURN.	HK/UTH
TABLE					
AM NO.					
DATE					
BURN.					
ALTERATIONS ONLY IN CADAM					
DESCRIPTION: LEVEL MONITORS			MACHINE: TBA/9-1401 S.A		
DRAWING REMARKS					
44093-26:01					

This drawing must not without the consent of Tetra Pak be copied, transmitted or disclosed to any third party.

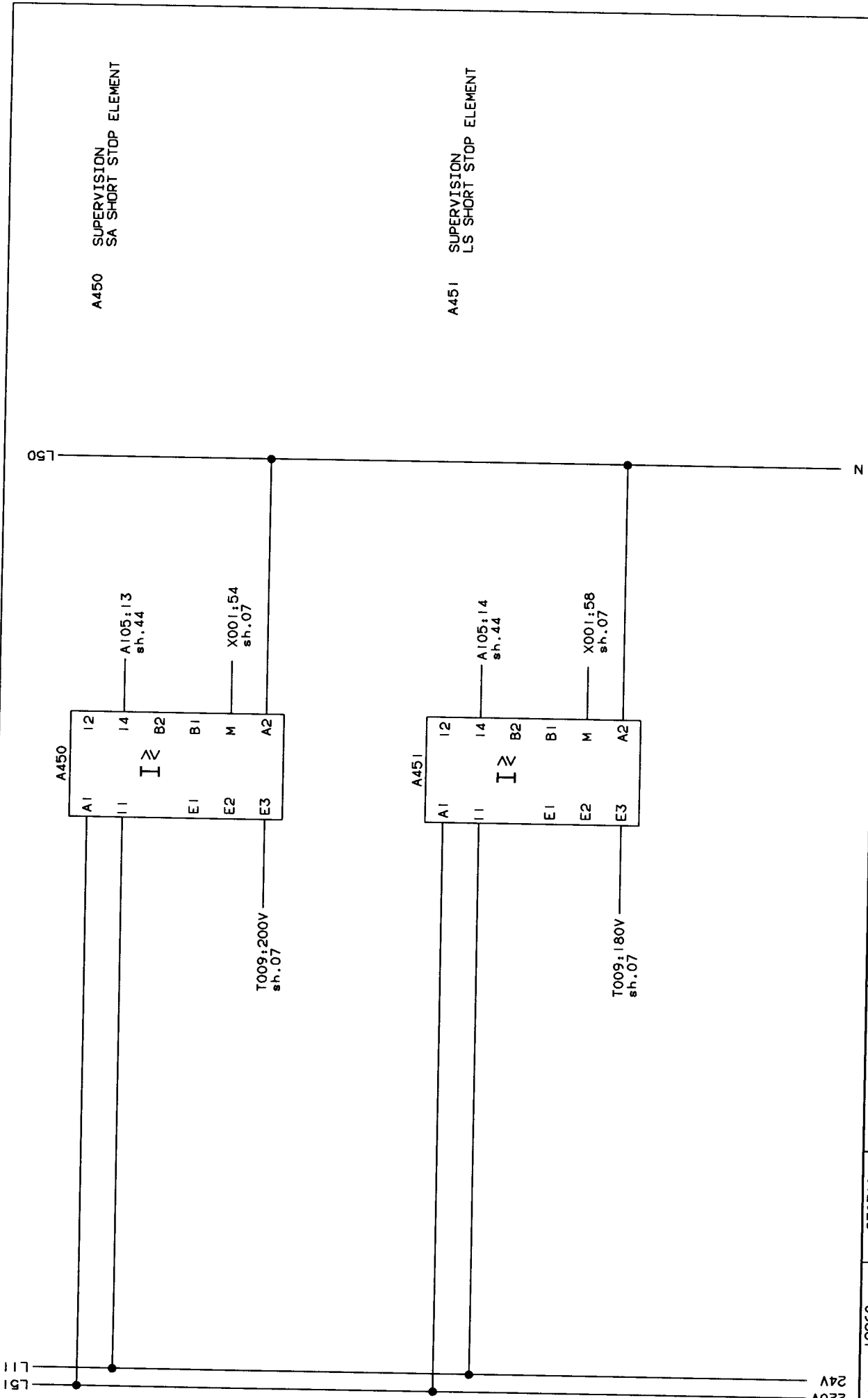

INTRODUCED WITH AM NO.	19260	DATE:	930310	SIGN.	HK/JUTH
TITLE					
AM NO.					
DATE					
SIGN.					
ALTERATIONS ONLY IN CADAM					
DESCRIPTION:				CURRENT MONITORS	
MACHINE:				TBA/9-1401 S.A.	
				44093-27:01	

This drawing must not without the consent of Tetra Pak be copied, transmitted or disclosed to any third party.

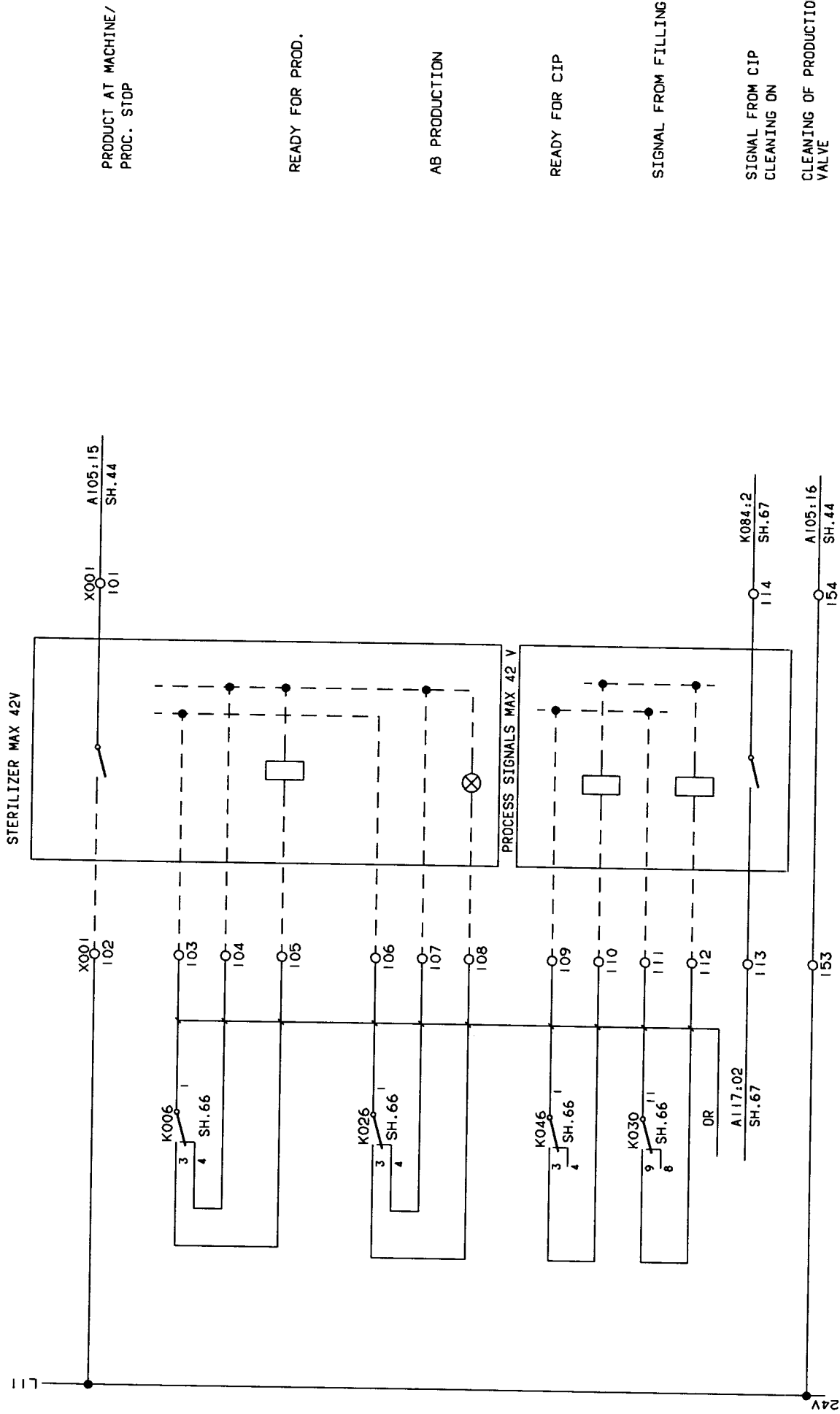

PRODUCT AT MACHINE/  
PROC. STOP

READY FOR PROD.

AB PRODUCTION

READY FOR CIP

SIGNAL FROM FILLING

SIGNAL FROM CIP  
CLEANING ON

CLEANING OF PRODUCTION  
VALVE

INTRODUCED WITH AM. NO.	19260	DATE:	930310	SIGN.	HK/UTH
ISSUE	A				
AM. NO.	20080				
DATE	930909				
SIGN.	HK/MRL				
ALTERATIONS ONLY IN CADAM					
DESCRIPTION:				STERILIZER	
MACHINE:				TBA/9-1401 S.A	
				44093-29:01	

This drawing must not without the consent of Tetra Pak be copied, transmitted or disclosed to any third party.

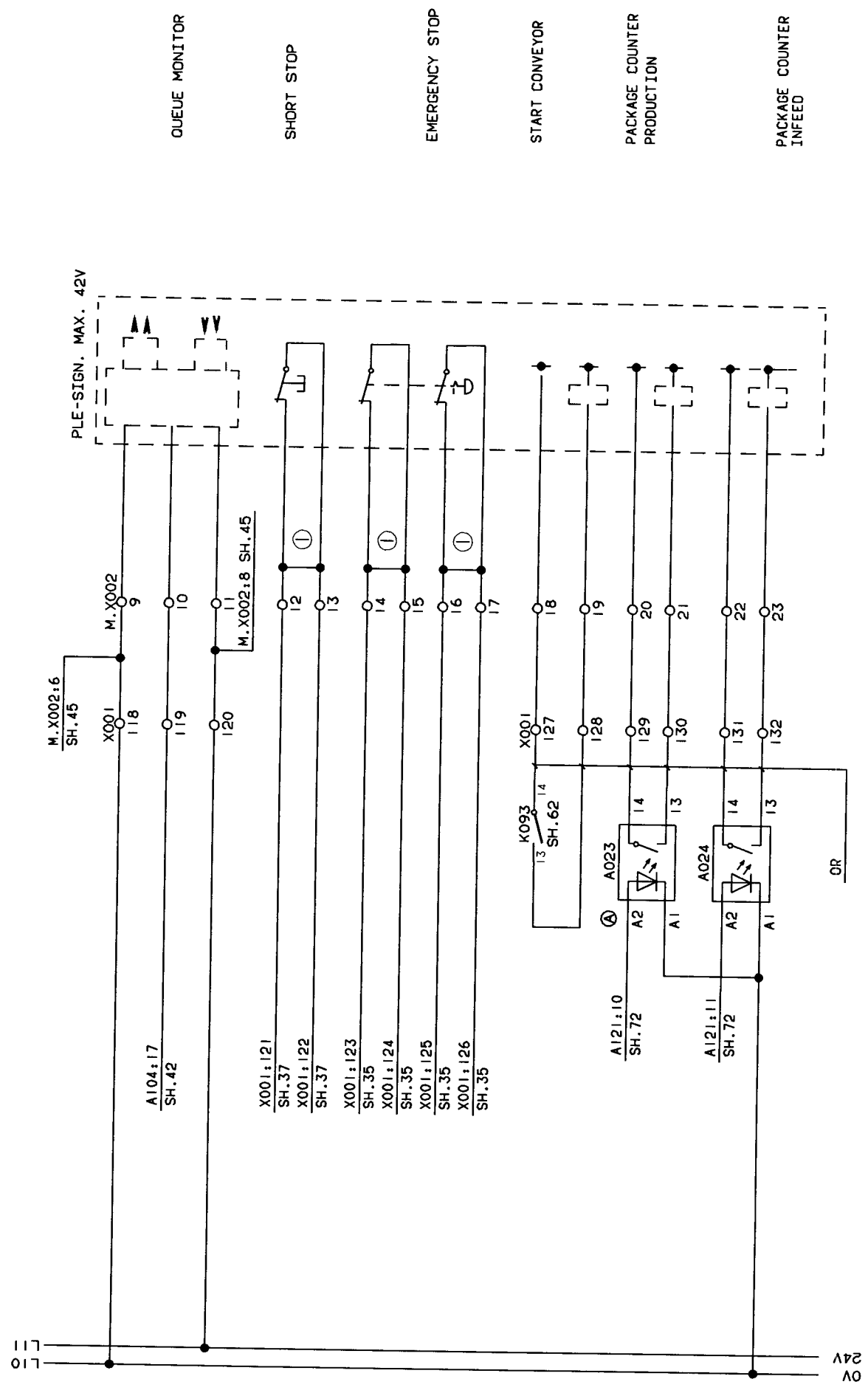

QUEUE MONITOR

SHORT STOP

EMERGENCY STOP

START CONVEYOR

PACKAGE COUNTER PRODUCTION

PACKAGE COUNTER INFEEED

INTRODUCED BY: AM NO	DATE: 19260	SIGN: HK/UTH	DESCRIPTION: PLE
DRAWN			
AM NO			
DATE			
SIGN			
ALTERATIONS ONLY IN CADAM			MACHINE: TBA/9-1401 S.A
			44093-30:01

This drawing must not without the consent of Tetra Pak be copied, transmitted or disclosed to any third party.

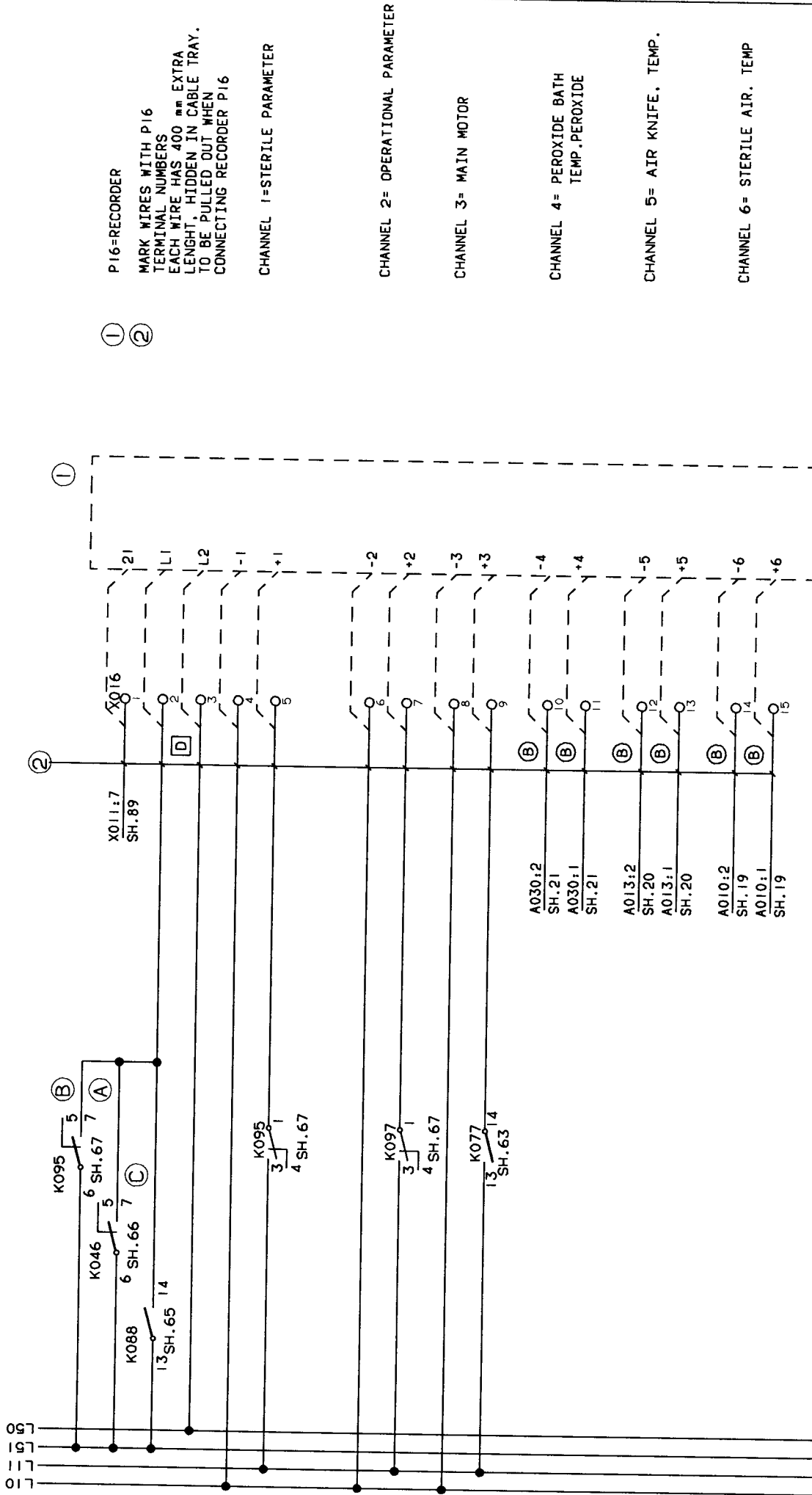

PI6=RECORDER

MARK WIRES WITH PI6  
TERMINAL NUMBERS  
EACH WIRE HAS 400 mm EXTRA  
LENGHT, HIDDEN IN CABLE TRAY.  
TO BE PULLED OUT WHEN  
CONNECTING RECORDER PI6

CHANNEL 1=STERILE PARAMETER

CHANNEL 2= OPERATIONAL PARAMETER

CHANNEL 3= MAIN MOTOR

CHANNEL 4= PEROXIDE BATH  
TEMP. PEROXIDE

CHANNEL 5= AIR KNIFE. TEMP.

CHANNEL 6= STERILE AIR. TEMP

0V  
24V  
220V  
N

INTRODUCED WITH AM. NO.	19260	DATE	930310	SIGN.	HK/UTH
JURISDICTION					
AM. NO.					
DATE					
SIGN.					
ALTERNATIONS ONLY IN CADAM					
DESCRIPTION: PROCESS RECORDER				MACHINE: TBA/9-1401 S.A	
44093-31:01					

This drawing must not without the consent of Tetra Pak be copied, transmitted or disclosed to any third party.

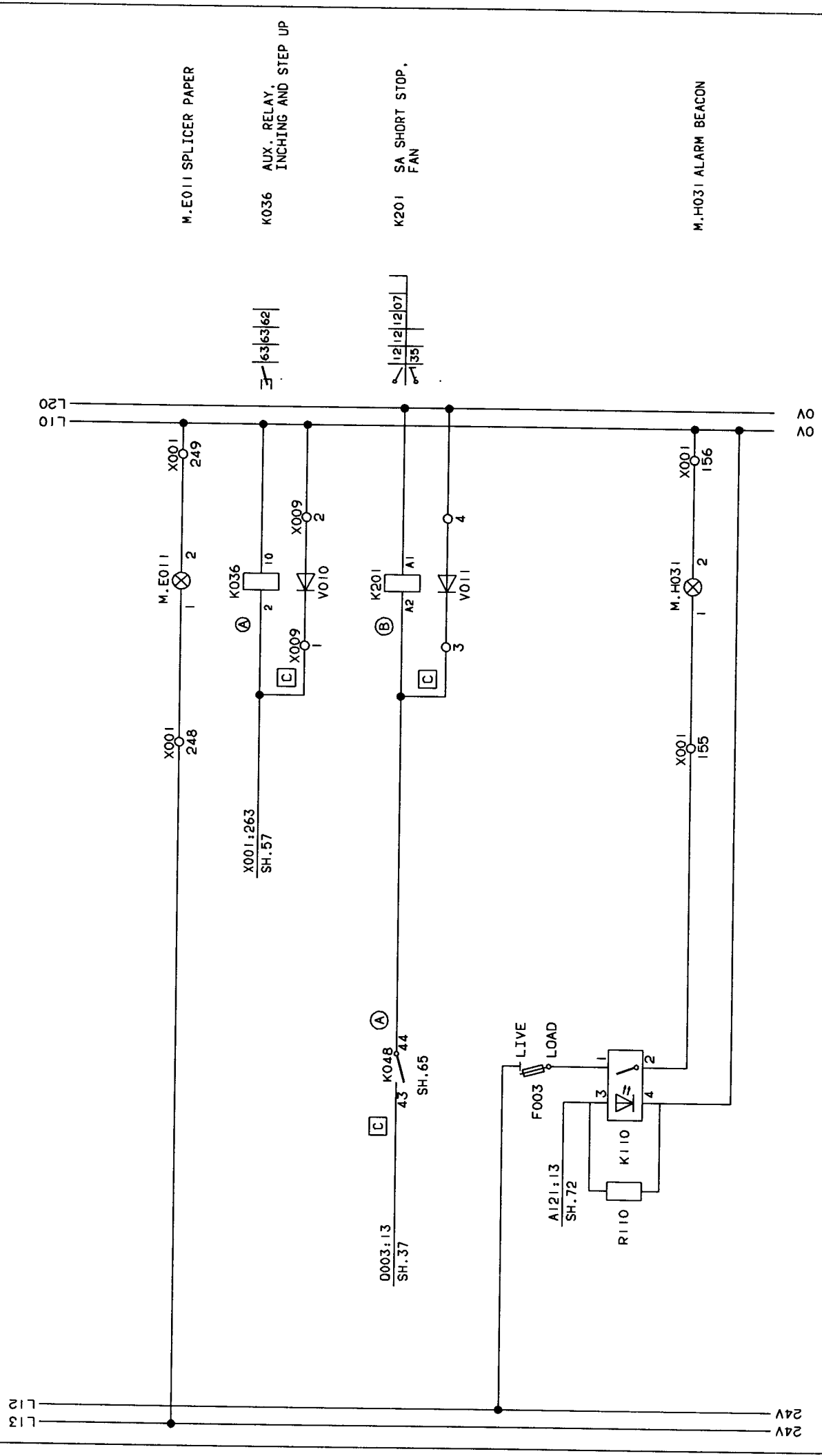

INTRODUCED BY: AM NO	DATE	930310	BY: HK/UTH
ISSUE	A		
AM NO	20080		
DATE	930909		
BY: HK/MRI			
ALTERATIONS ONLY IN CADAM			
DESCRIPTION:		AUXILIARY RELAYS	
MACHINE:		TBA/9-1401 S.A	
		44093-32:01	

This drawing must not without the consent of Tetra Pak be copied, transmitted or disclosed to any third party.

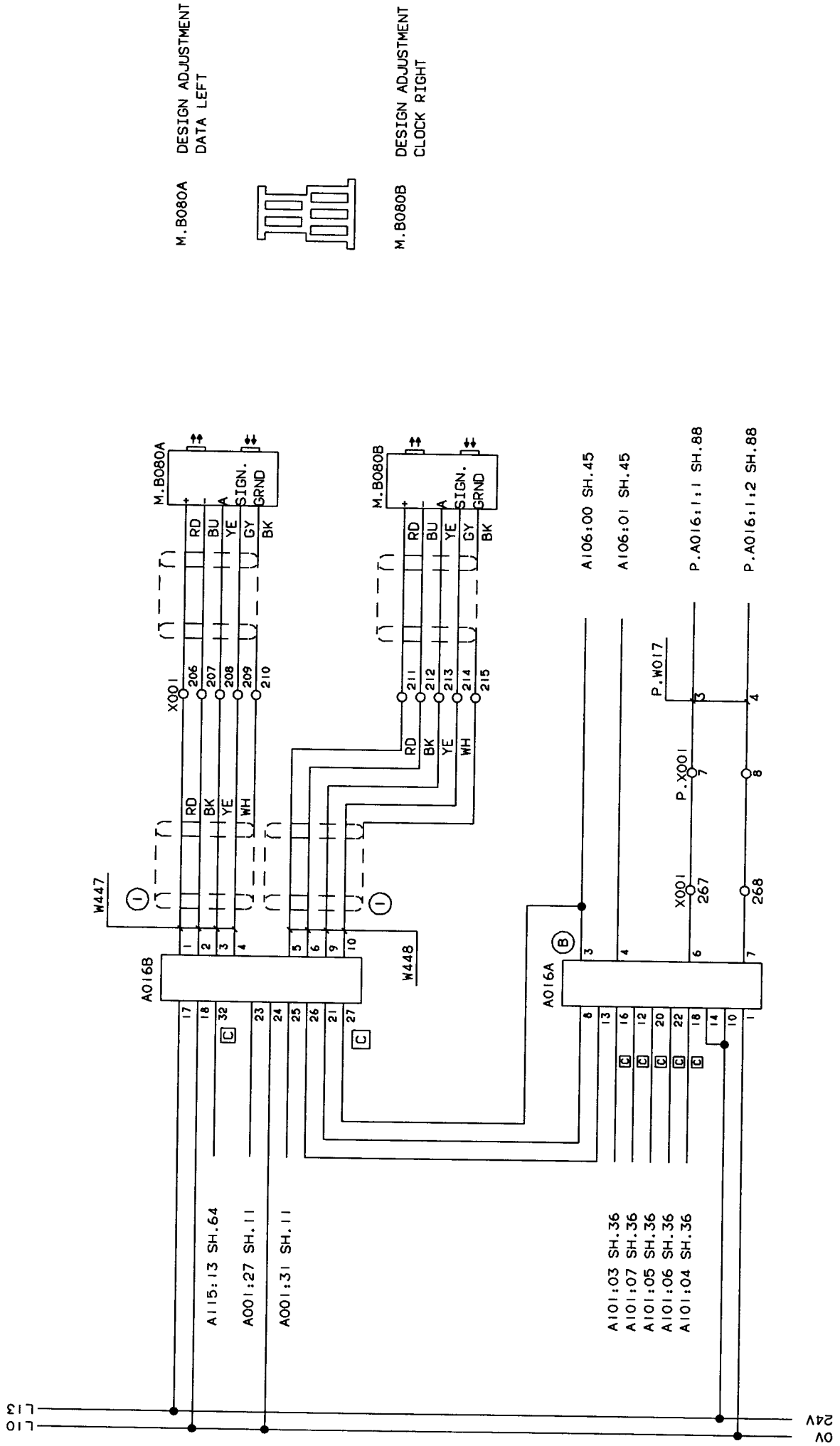

OV 24V

INTRODUCED BY: AM. NO.	19260	DATE:	930310	SIGN.	HK/UTH	SHIELD SHALL BE CUT OFF AT A016B	
DRAWING NO.	A	REV. NO.	20080	DATE:	930909	DESCRIPTION: PRINTED DESIGN CORRECTION	
BY:	HK/MRI	DATE:		DATE:		MACHINE: TBA/9-1401 S.A 44093-34:01	
ALTERATIONS ONLY IN CADAM							



This drawing must not without the consent of Tetra Pak, be copied, transmitted or disclosed to any third party.

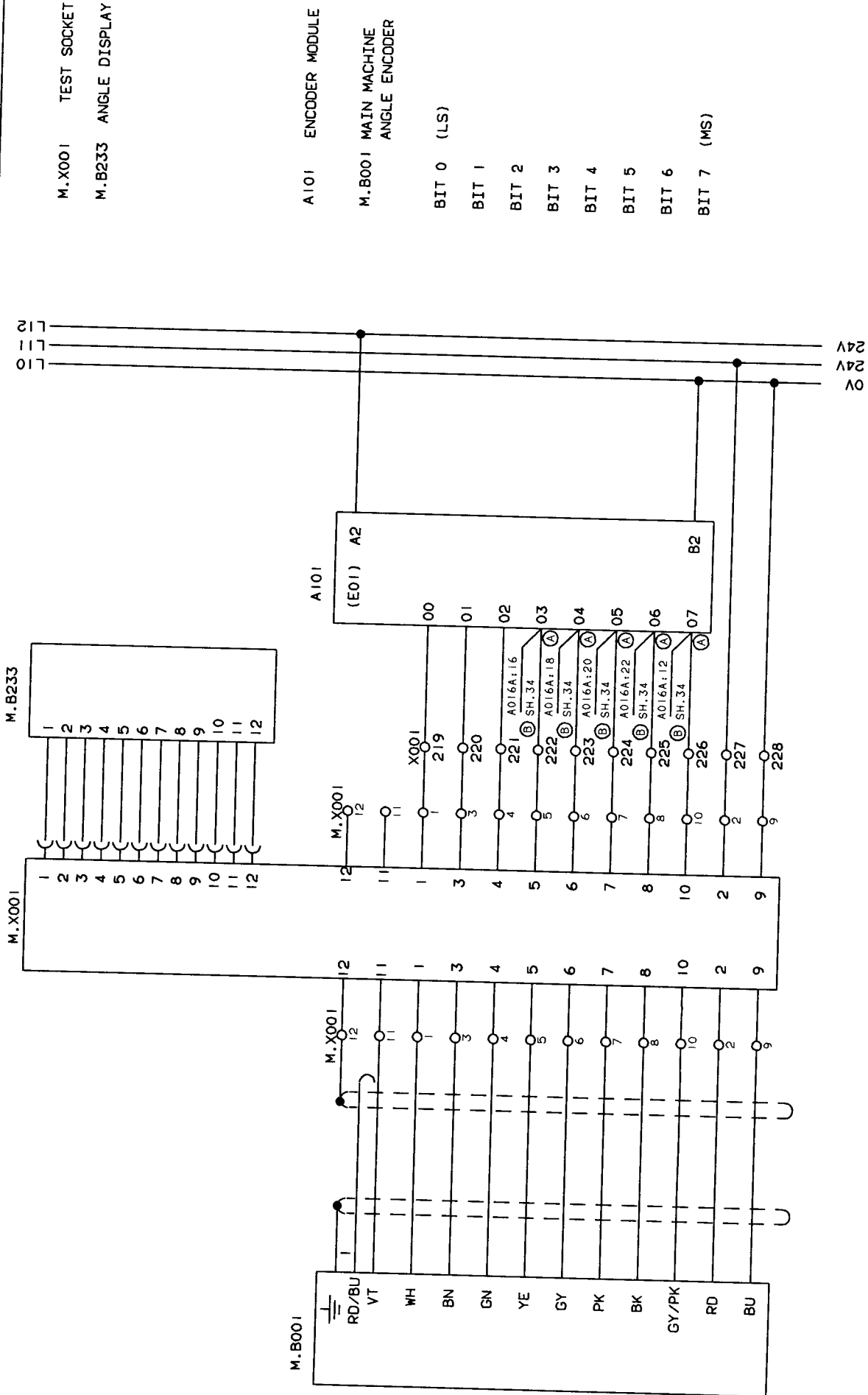

INTRODUCED WITH AM NO.	19260	DATE	930310	BY	HK/UTH
ISSUE					
AM NO.					
DATE					
BY					
ALTERATIONS ONLY IN CADAM					
DESCRIPTION:				ANGLE ENCODER, MAIN MACHINE	
MACHINE:				TBA/9-1401 S.A	
				44093-36:01	



This drawing must not without the consent of Tetra Pak be copied, transmitted or disclosed to any third party.

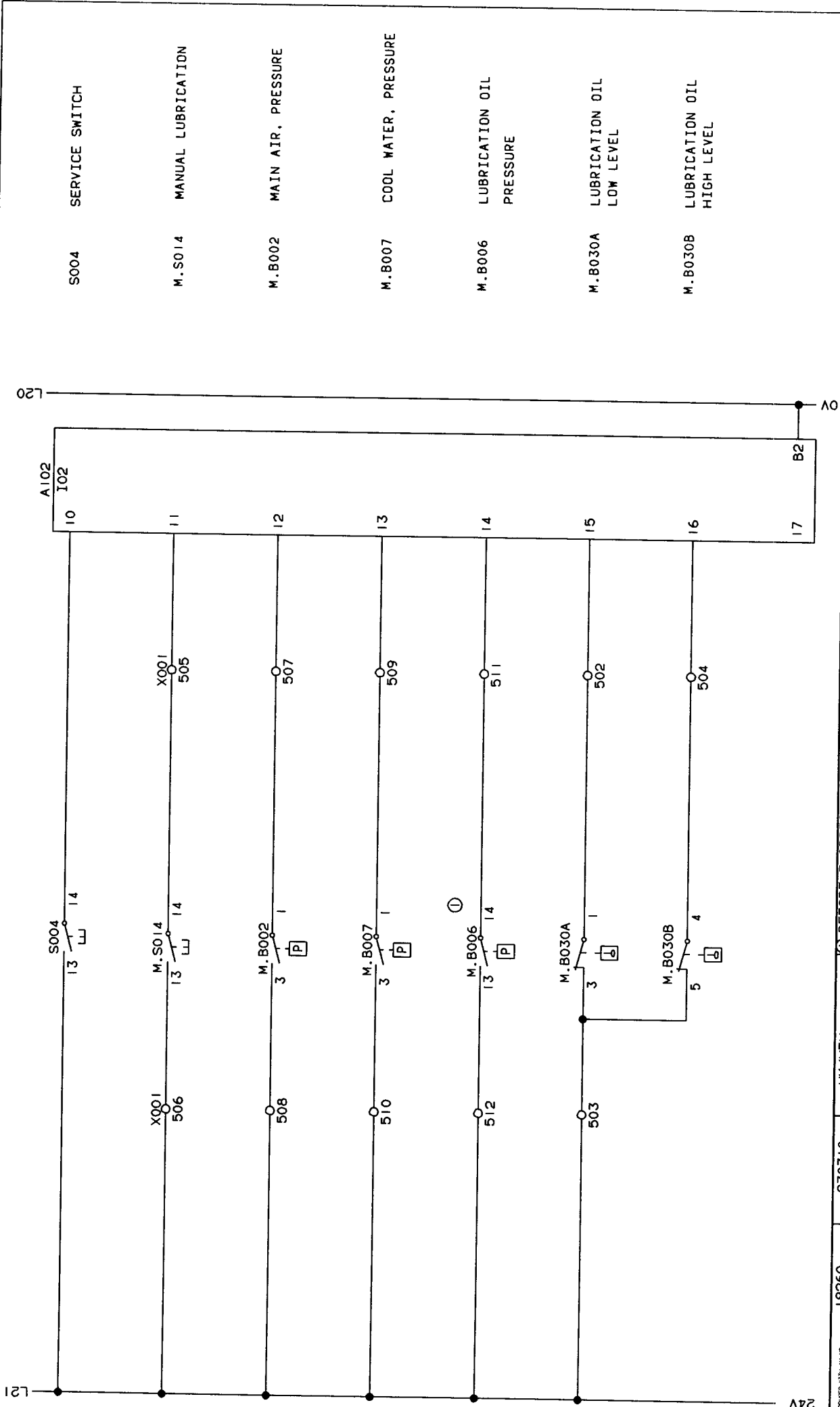

24V

- S004 SERVICE SWITCH
- M.S014 MANUAL LUBRICATION
- M.B002 MAIN AIR, PRESSURE
- M.B007 COOL WATER, PRESSURE
- M.B006 LUBRICATION OIL PRESSURE
- M.B030A LUBRICATION OIL LOW LEVEL
- M.B030B LUBRICATION OIL HIGH LEVEL

INTRODUCED BY: AN NO.	19260	DATE:	930310	SIGN:	HK/UTH
ISSUE	A				
	B				
APP NO.	20080		20406		
DATE	930909		931015		
SIGN	HK/MRI		HK/MRI		
ALTERATIONS ONLY IN CADAM					
DESCRIPTION: PLC-IN, OPERATION MONITORS					
MACHINE: TBA/9-1401 S.A					
DRAWING REMARKS					
DRAWING NO: 44093-38:01					

Ⓢ BEFORE T-ORDER T-13147 AND T-20163 THE CONNECTION IS 1 AND 3 INSTEAD OF 13 AND 14

This drawing must not without the consent of Tetra Pak be copied, transmitted or disclosed to any third party.

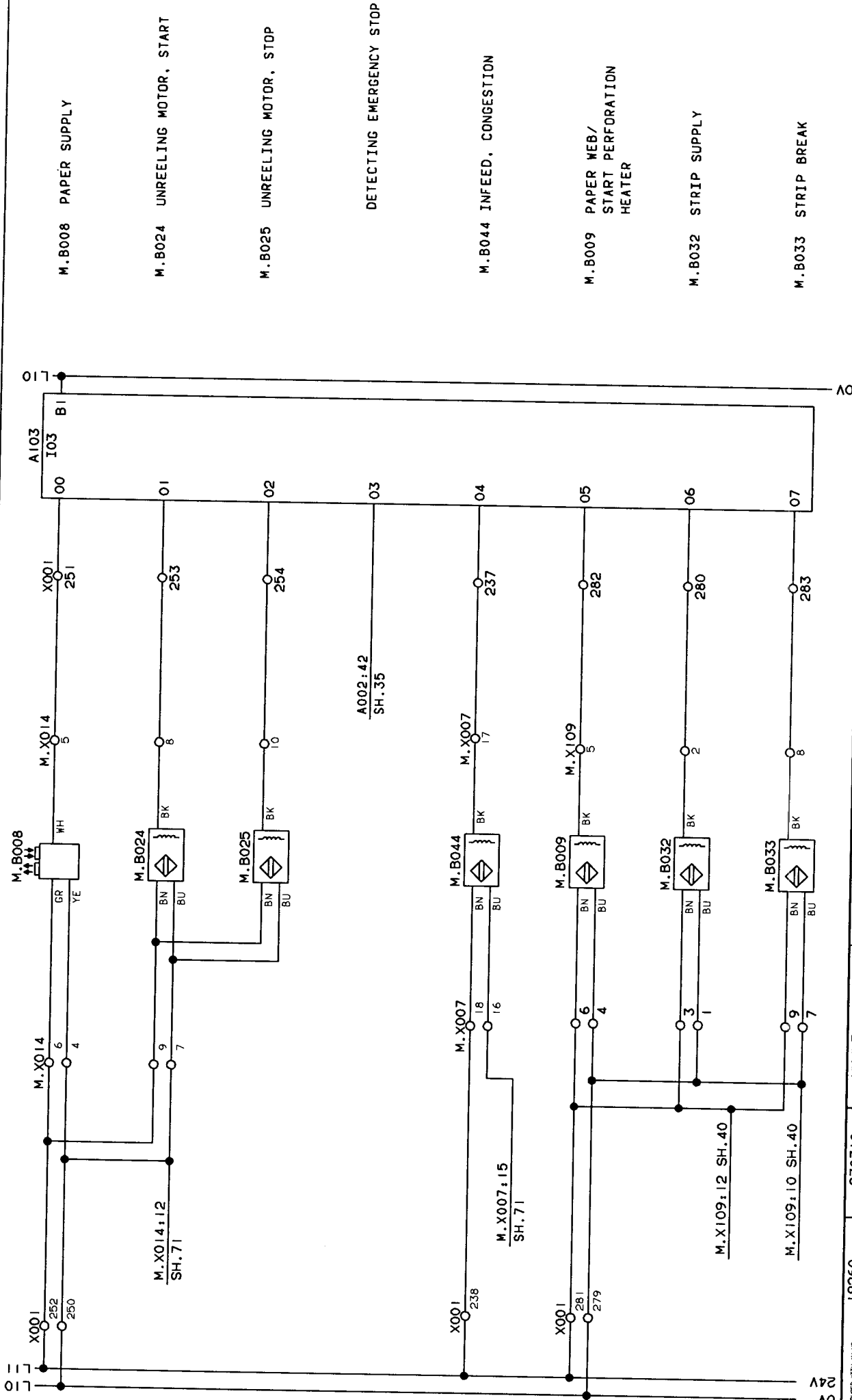

INTRODUCED BY: AM NO.	19260	DATE:	930310	REV:	HK/UTH
TITLE					
AM NO.					
DATE					
BY					
ALTERNATIONS ONLY IN CADAM					
DESCRIPTION:				PLC-IN, OPERATION MONITORS	
MACHINE:				TBA/9-1401 S.A	
				44093-39:01	

This drawing must not without the consent of Tetra Pak, be copied, transmitted or disclosed to any third party.

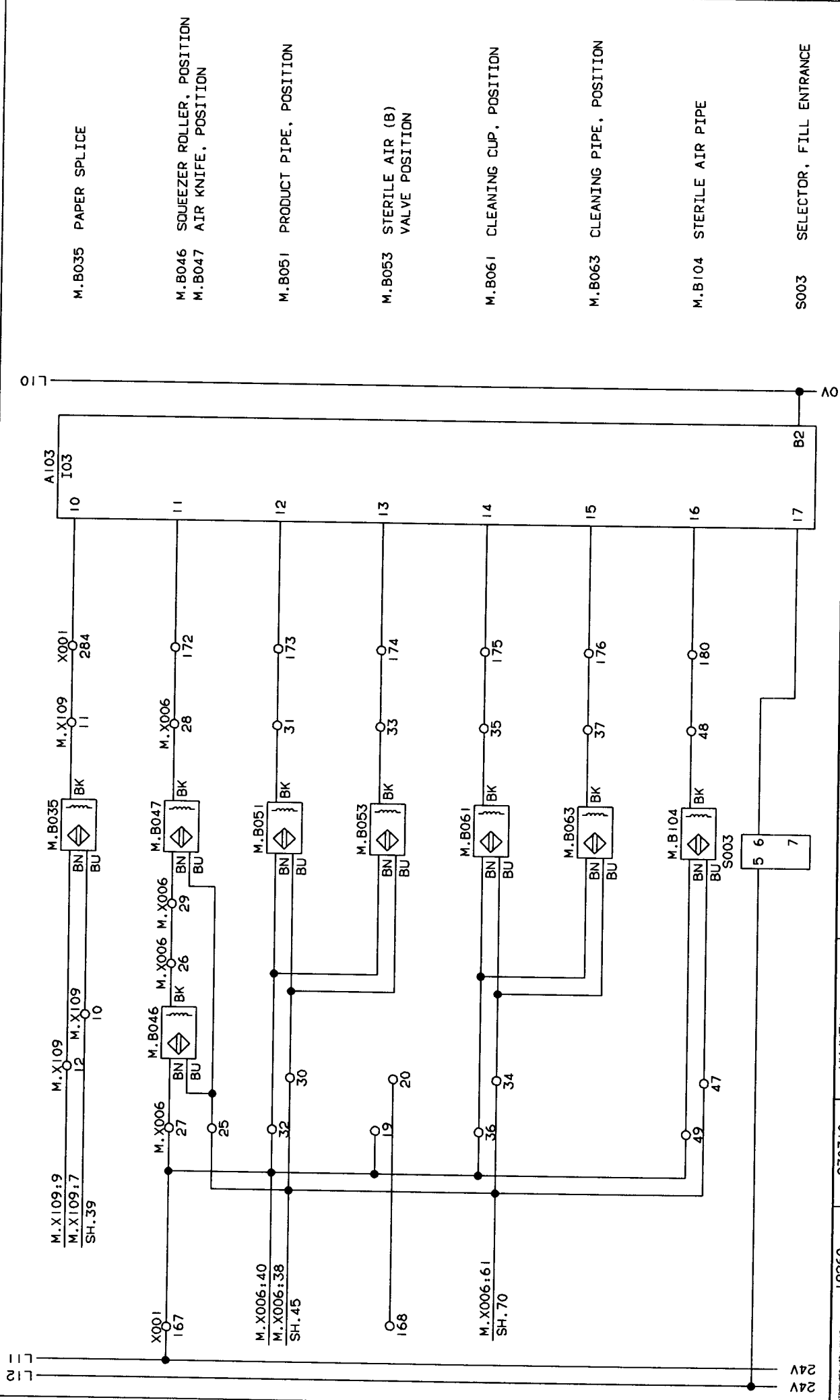

M.B035 PAPER SPLICE

M.B046 SQUEEZER ROLLER, POSITION  
M.B047 AIR KNIFE, POSITION

M.B051 PRODUCT PIPE, POSITION

M.B053 STERILE AIR (B)  
VALVE POSITION

M.B061 CLEANING CUP, POSITION

M.B063 CLEANING PIPE, POSITION

M.B104 STERILE AIR PIPE

S003 SELECTOR, FILL ENTRANCE

INTRODUCED WITH AM. NO.	19260	DATE	930310	SIGN.	HK/UTH
TABLE NO.	A	AN. NO.	20080	DATE	930909
BY	HK/MRI	DATE		DATE	
ALTERATIONS ONLY IN COLUMNS					
DESCRIPTION:				PLC-IN, OPERATION MONITORS	
MACHINE:				TBA/9-1401 S.A	
				44093-40:01	

This drawing must not without the consent of Tetra Pak be copied, transmitted or disclosed to any third party.

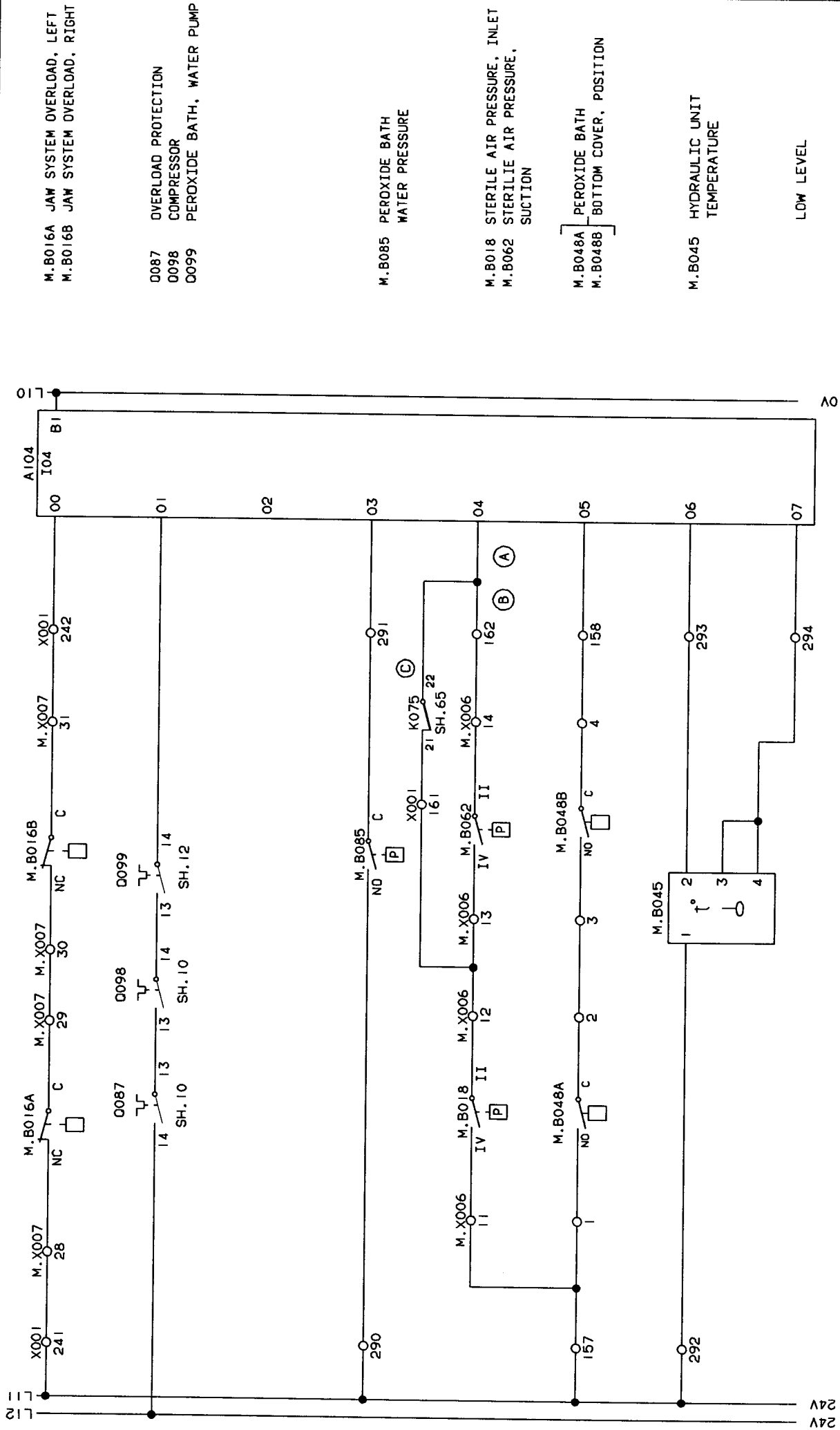

INTRODUCED BY: AN NO.	19260	DATE:	930310	BY:	HK/UTH
FRANK	A				
REV. NO.	20080				
DATE	930909				
BY:	HK/MRI				
ALTERATIONS ONLY IN CADAM					
DESCRIPTION:				PLC-IN, OPERATION MONITORS	
MACHINE:				TBA/9-1401 S.A	
				44093-41:01	

This drawing must not without the consent of Tetra Pak be copied, transmitted or disclosed to any third party.

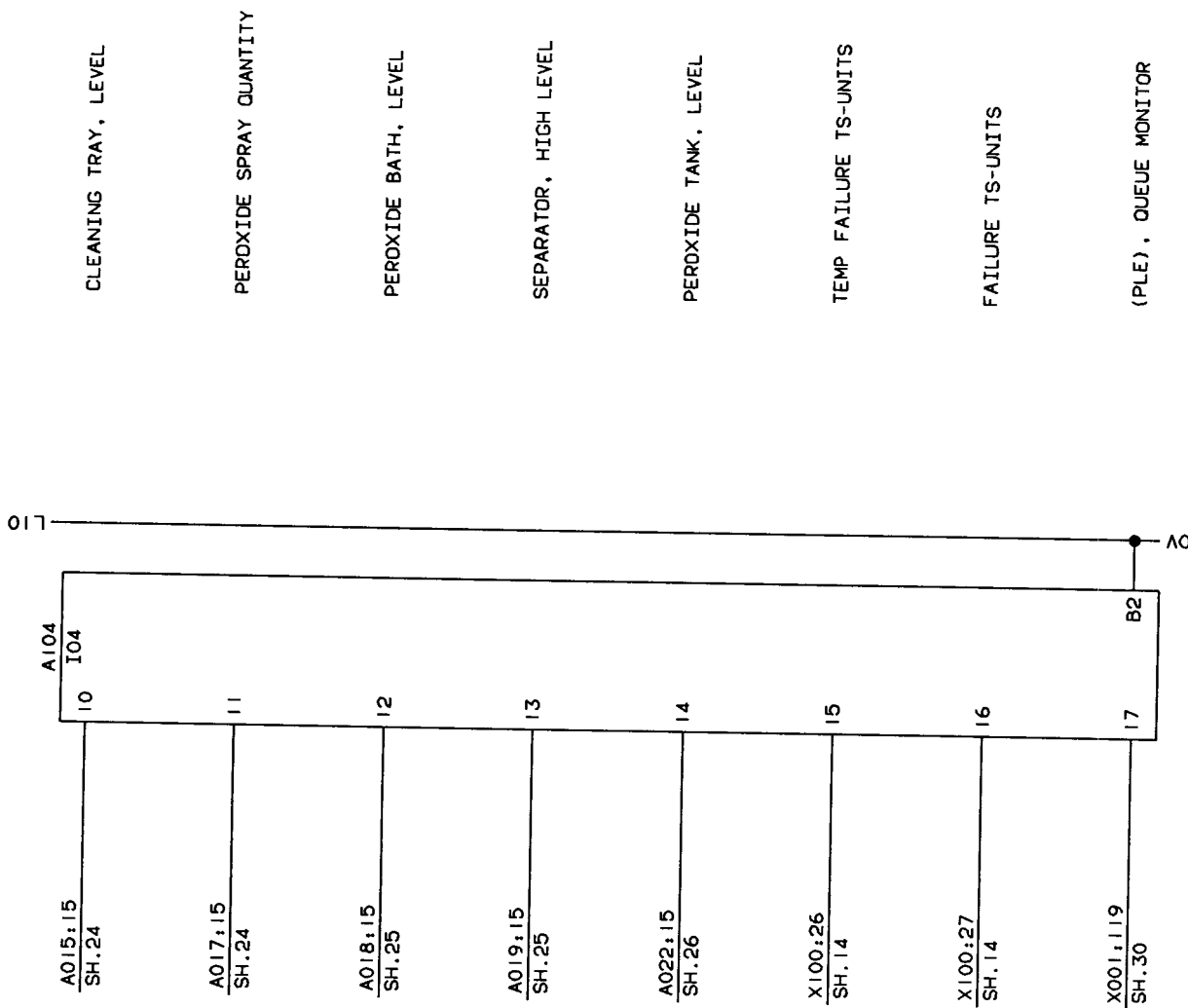

INTRODUCED WITH AM NO.	19260	DATE	930310	SIGN.	HK/UTH	DESCRIPTION	PLC-IN
ISSUE							
AM NO.							
DATE							
BY							
DRAWING REMARKS							
ALTERATIONS ONLY IN CADAM							MACHINE: TBA/9-1401 S.A
							44093-42:01

This drawing must not without the consent of Tetra Pak be copied, transmitted or disclosed to any third party.

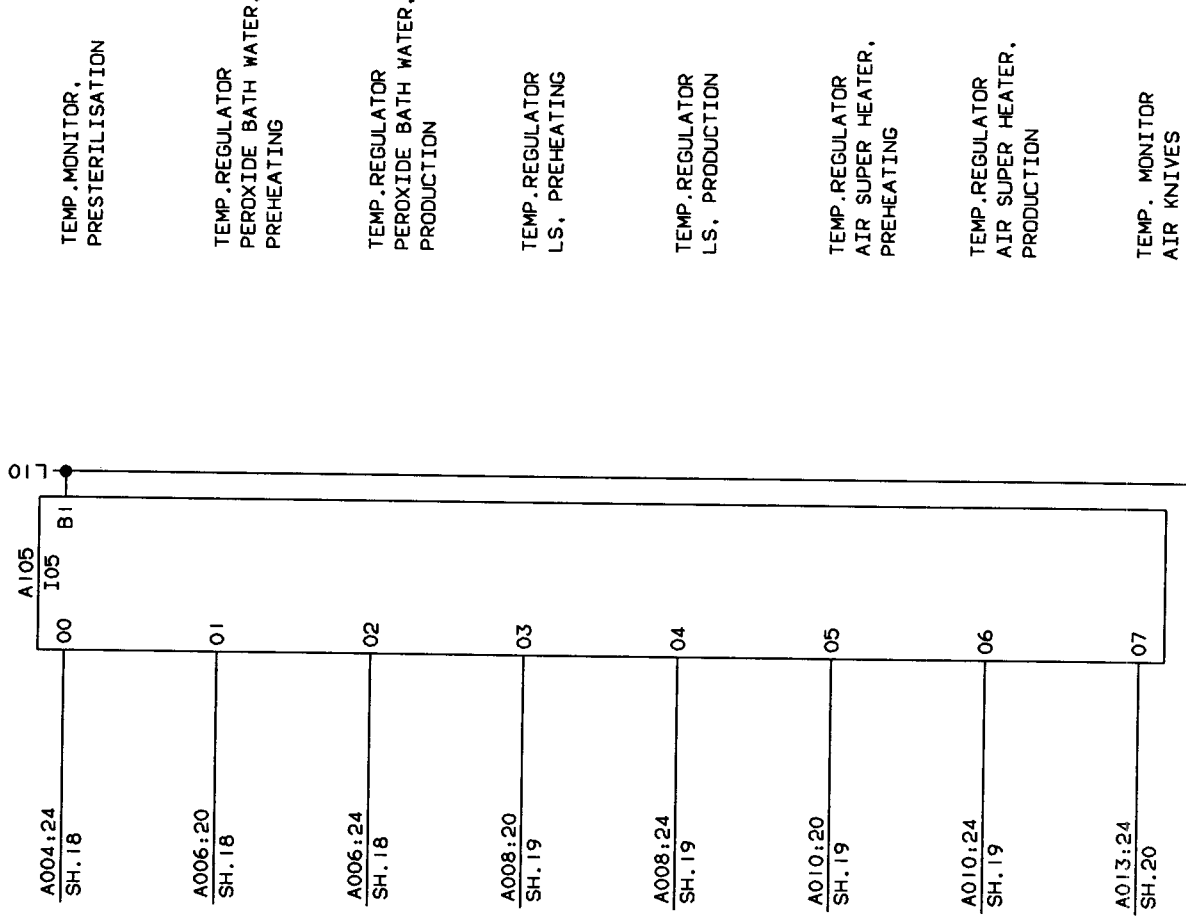

INTRODUCED BY AM. NO.	19260	DATE	930310	BY	HK/LJTH
ISSUE					
AM. NO.					
DATE					
BY					
ALTERATIONS ONLY IN CADAM					
DESCRIPTION: PLC-IN				MACHINE: TBA/9-1401 S.A	
				44093-43:01	

This drawing must not without the consent of Tetra Pak be copied, transmitted or disclosed to any third party.

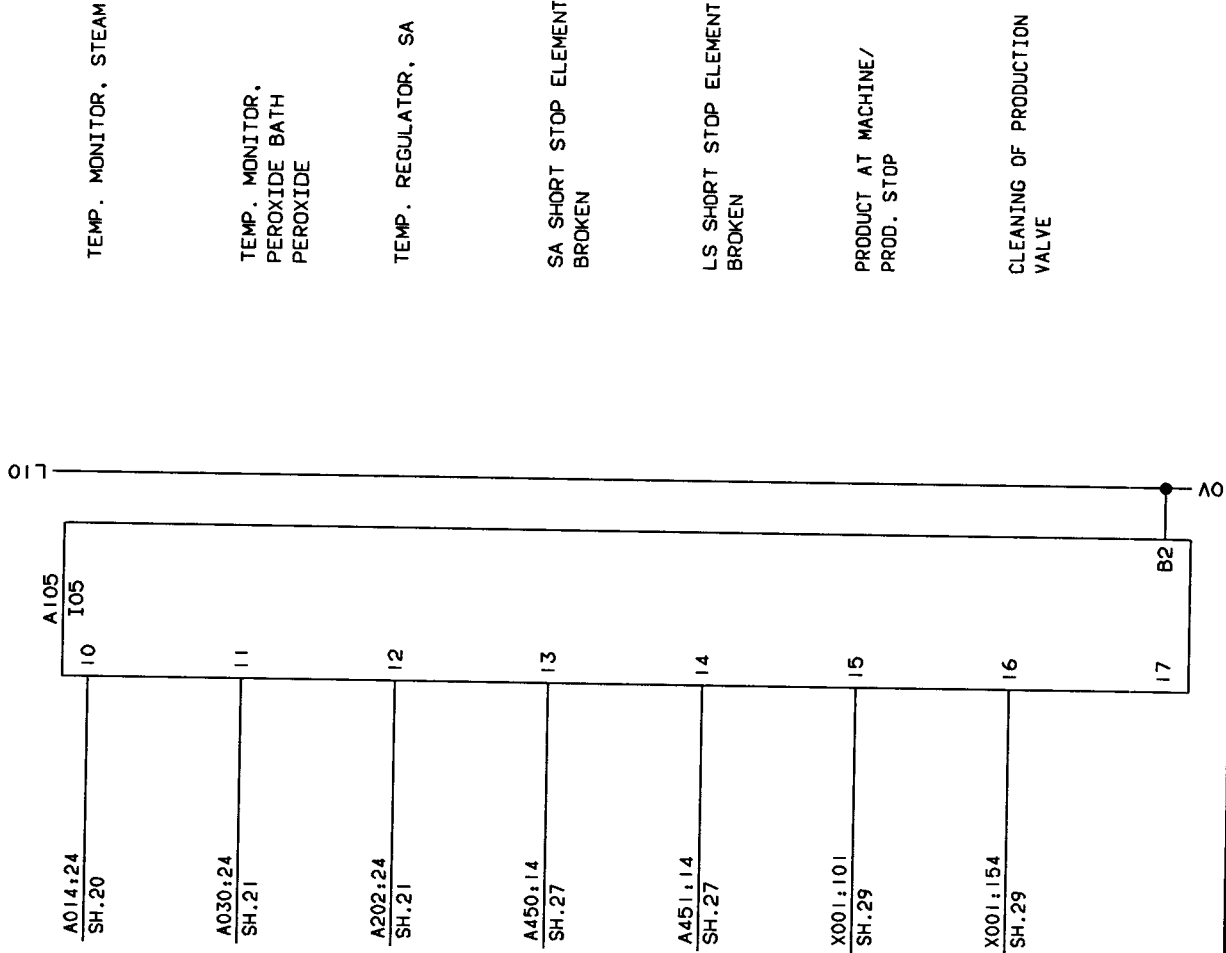

INTRODUCED WITH AM NO.	19260	DATE	930310	STED	HK/UTH
TABLE					
AM NO					
DATE					
STED					
ALTERATIONS ONLY IN CADAM					
DESCRIPTION: PLC-IN				MACHINE: TBA/9-1401 S.A	
				44093-44:01	
DRAWING REMARKS					

This drawing must not without the consent of Tetra Pak be copied, transmitted or disclosed to any third party.

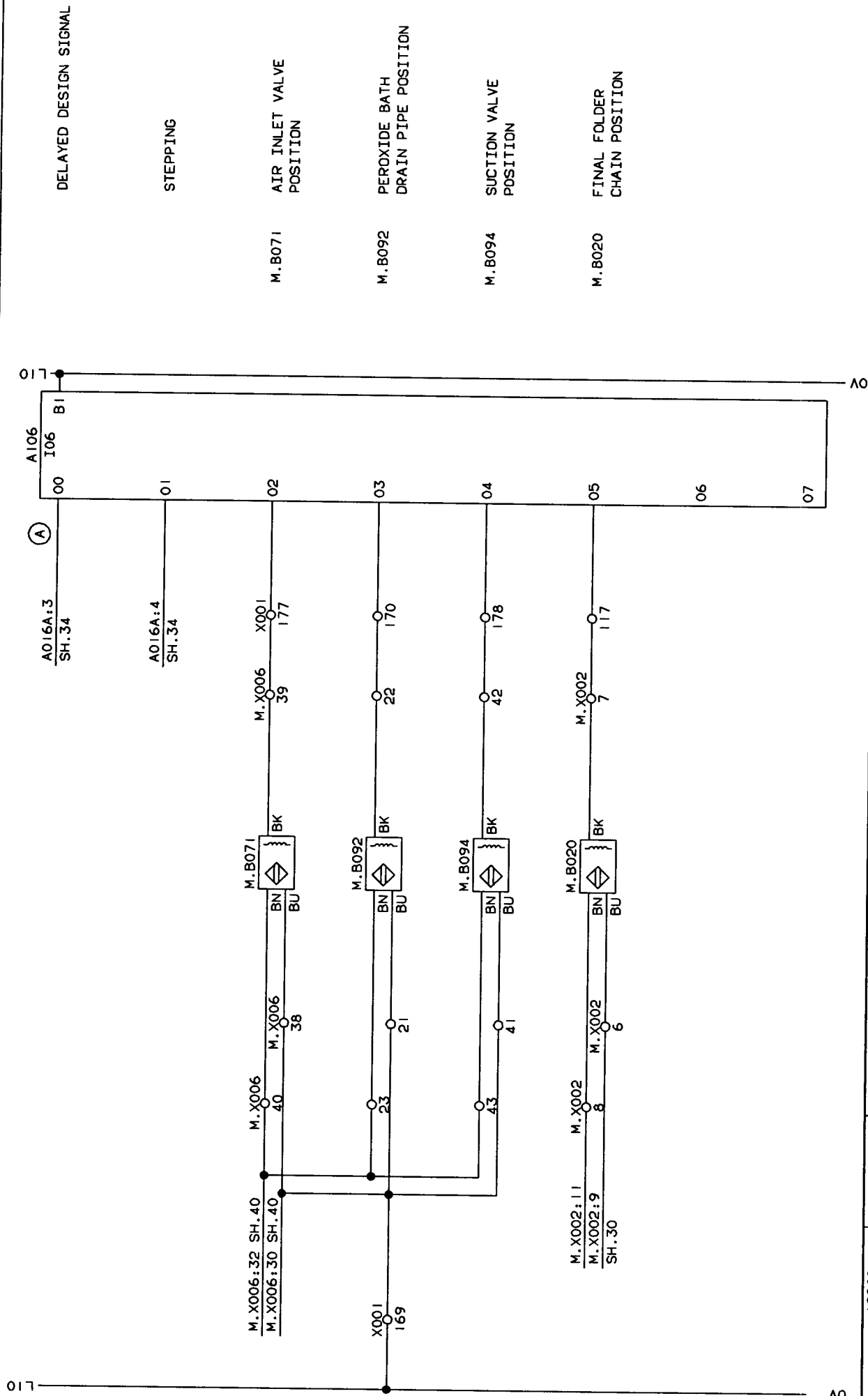

INTRODUCED BY: AM. NO.	DATE	930310	BY: HK/UTH	DESCRIPTION:	PLC-IN, FAST SCAN
TABLE					
AM. NO.					
DATE					
BY: BK					
ALTERATIONS ONLY IN CADAM					
				MACHINE:	TBA/9-1401 S.A
					44093-45:01

This drawing must not without the consent of Tetra Pak be copied, transmitted or disclosed to any third party.

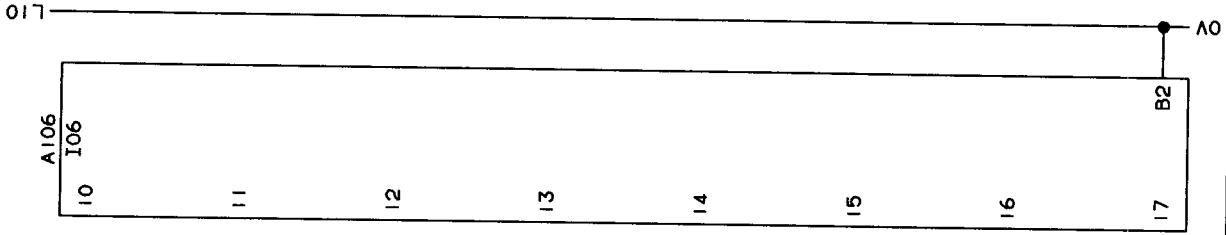

INTRODUCED WITH AM NO.	19260	DATE	930310	EDN.	HK/UTH	DESCRIPTION	PLC-IN	
TITLE								
AM NO.								
DATE								
EDN.								
ALTERATIONS ONLY IN CADAM							MACHINE	TBA/9-1401 S.A
DRAWING REMARKS								44093-46:01

This drawing must not without the consent of Tetra Pak be copied, transmitted or disclosed to any third party.

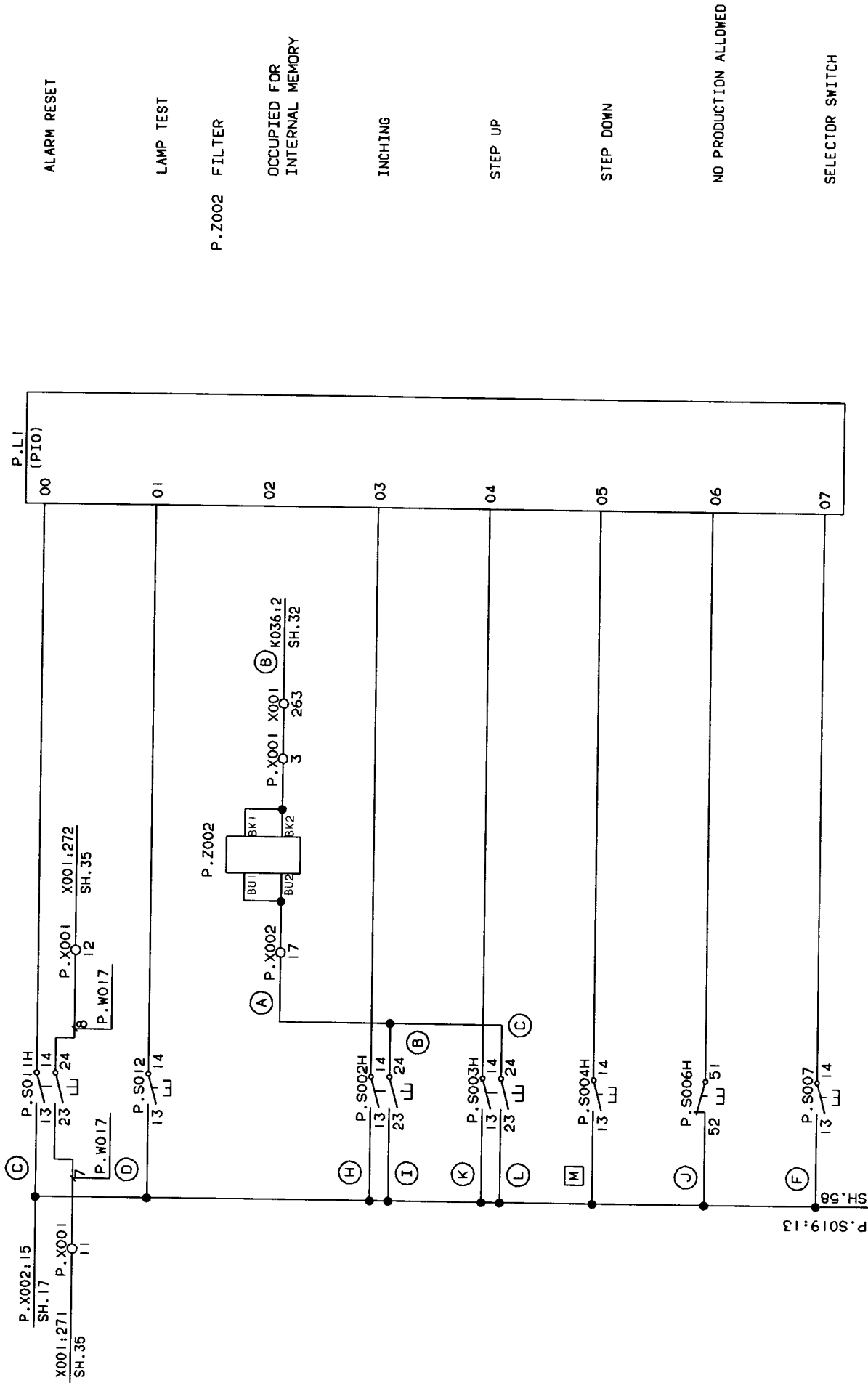

- ALARM RESET
- LAMP TEST
- P.Z002 FILTER
- OCCUPIED FOR INTERNAL MEMORY
- INCHING
- STEP UP
- STEP DOWN
- NO PRODUCTION ALLOWED
- SELECTOR SWITCH

INTRODUCED BY: AN NO	19260	DATE	930310	STEN	HK/UTH
TABLE	A				
AN NO	20080				
DATE	930825				
STEN	HK/PSG				
ALTERATIONS ONLY IN CADAM					
				DESCRIPTION:	PANEL INTERFACE, IN
				MACHINE:	TBA/9-1401 S.A
					44093-57:01

This drawing must not without the consent of Tetra Pak, be copied, transmitted or disclosed to any third party.

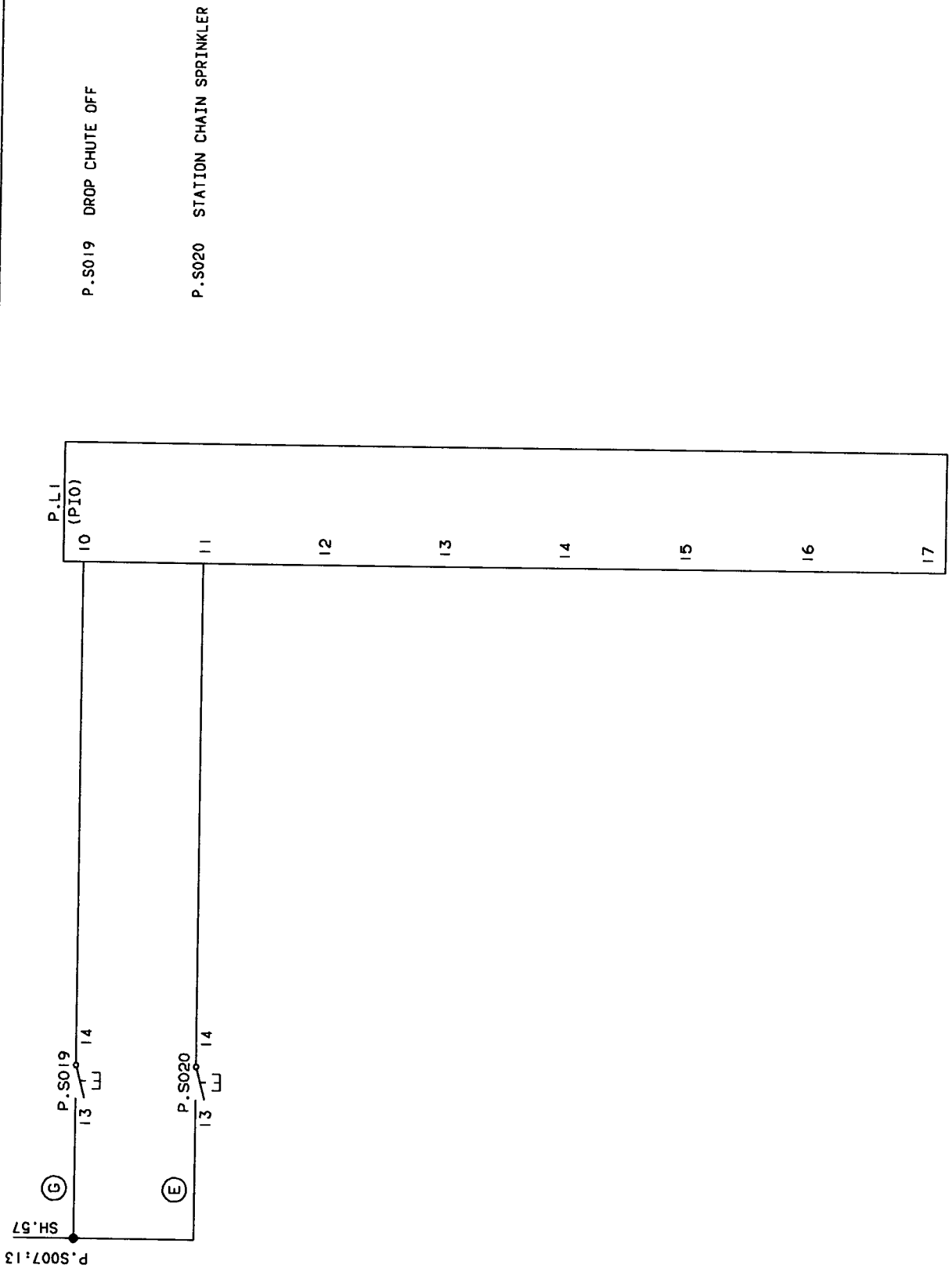

P.S019 DROP CHUTE OFF

P.S020 STATION CHAIN SPRINKLER

INTRODUCED WITH AM NO.	19260	DATE	930310	SIGN.	HK/JTH
TITLE					
AM NO.					
DATE					
SIGN.					
ALTERATIONS ONLY IN CADAM					
				DESCRIPTION:	PANEL INTERFACE, IN
				MACHINE:	TBA/9-1401 S.A
					44093-58:01

DRAWING REMARKS

This drawing must not without the consent of Tetra Pak be copied, transmitted or disclosed to any third party.

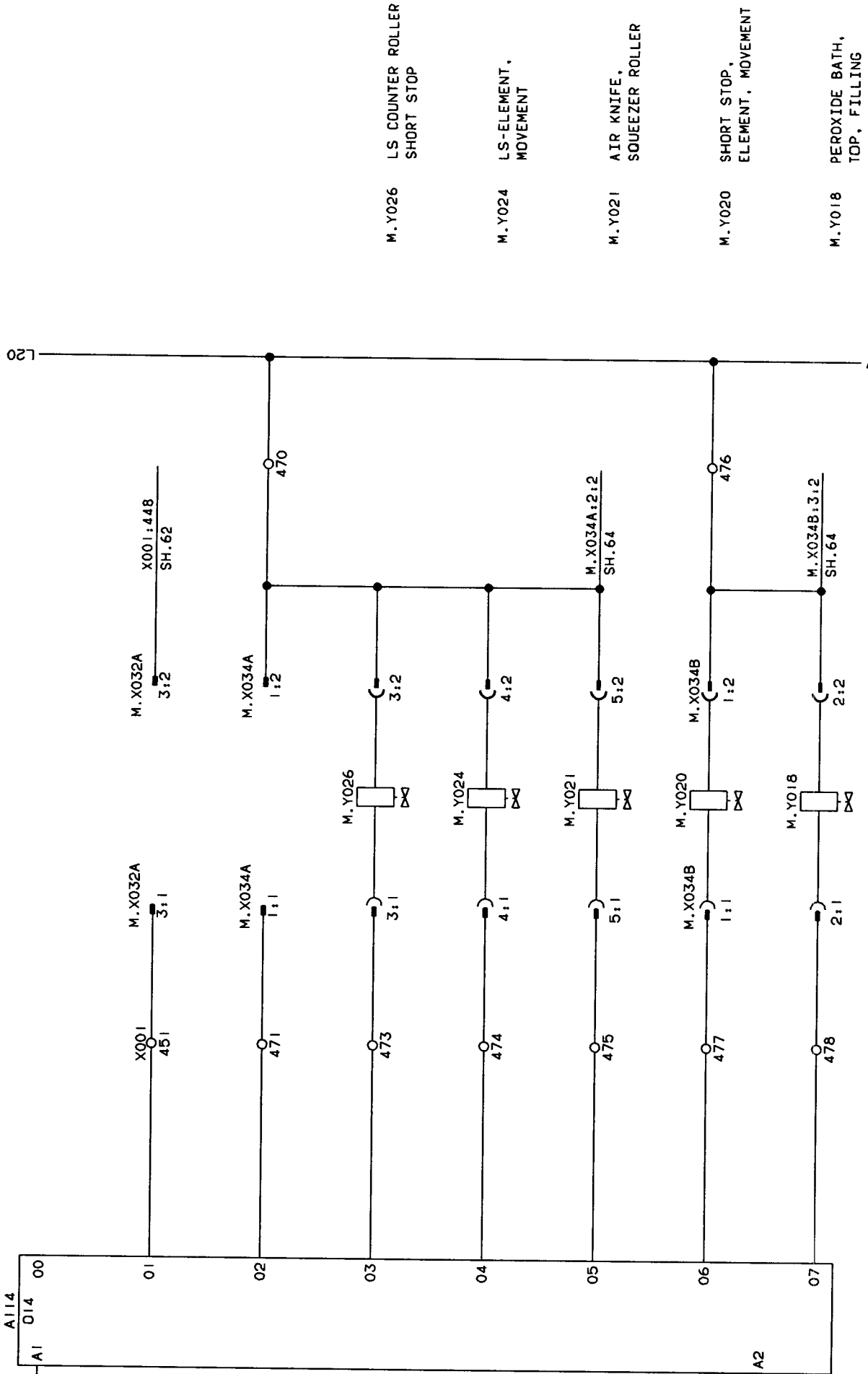

INTRODUCED BY: AN NO	DATE	930310	BIDN.	HK/UTH	DESCRIPTION:
					PLC-OUT, VALVES
DATE					
DATE					
BIDN.					
DRAWING REMARKS					MACHINE: TBA/9-1401 S.A
ALTERATIONS ONLY IN CADAM					44093-61:01

This drawing must not without the consent of Tetra Pak be copied, transmitted or disclosed to any third party.

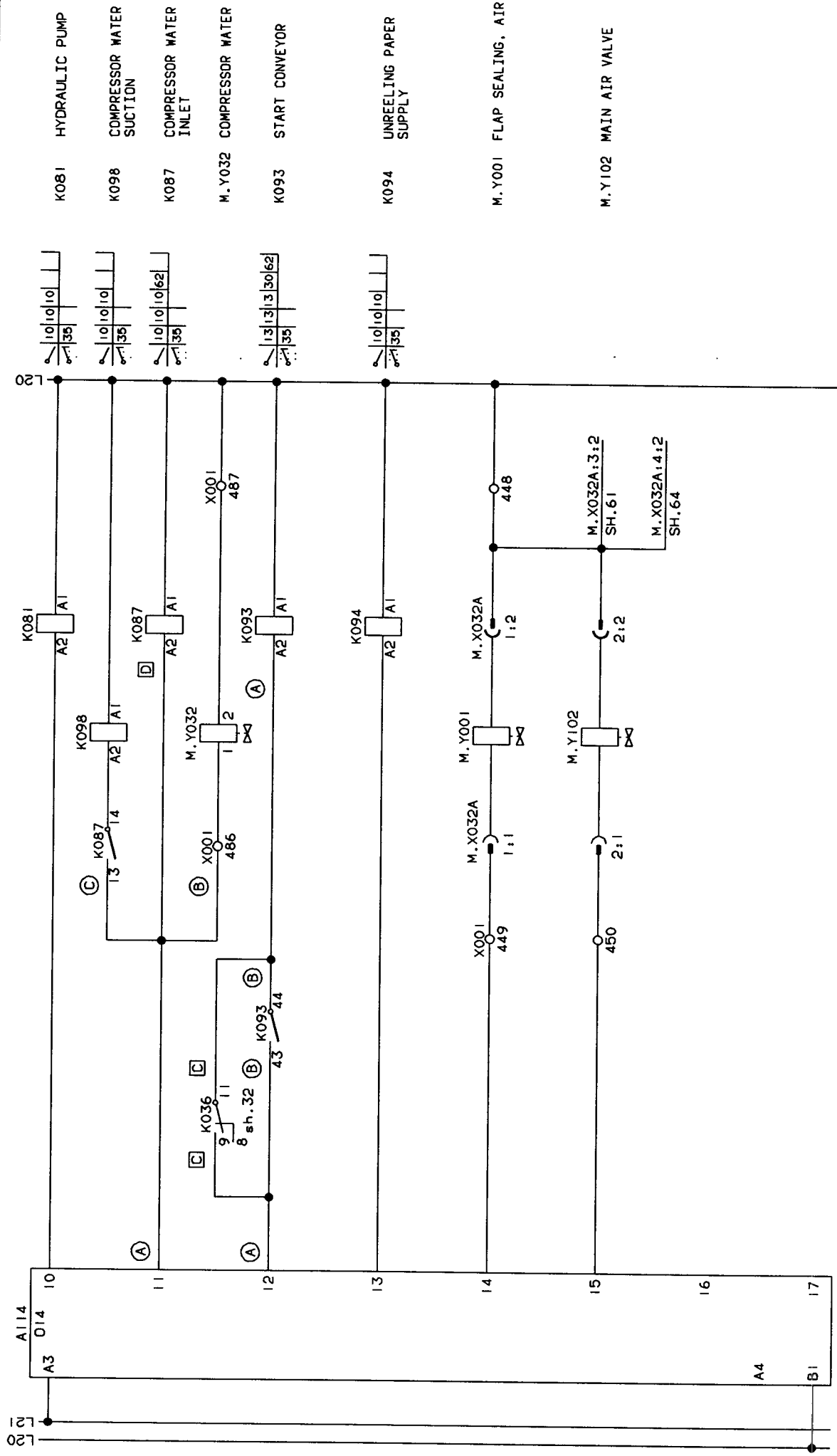

2V  
2AV

30

INTRODUCED BY: AM. NO.	19260	DATE:	930310	SIGN.	HK/UTH
TABLE	A				
REV. NO.	20080				
DATE	930909				
SIGN.	HK/MRI				
ALTERATIONS ONLY IN CADAM					
DESCRIPTION:			PLC OUT, EMERGENCY MODULE		
MACHINE:			TBA/9-1401 S.A		
			44093-62:01		



This drawing must not without the consent of Tetra Pak be copied, transmitted or disclosed to any third party.

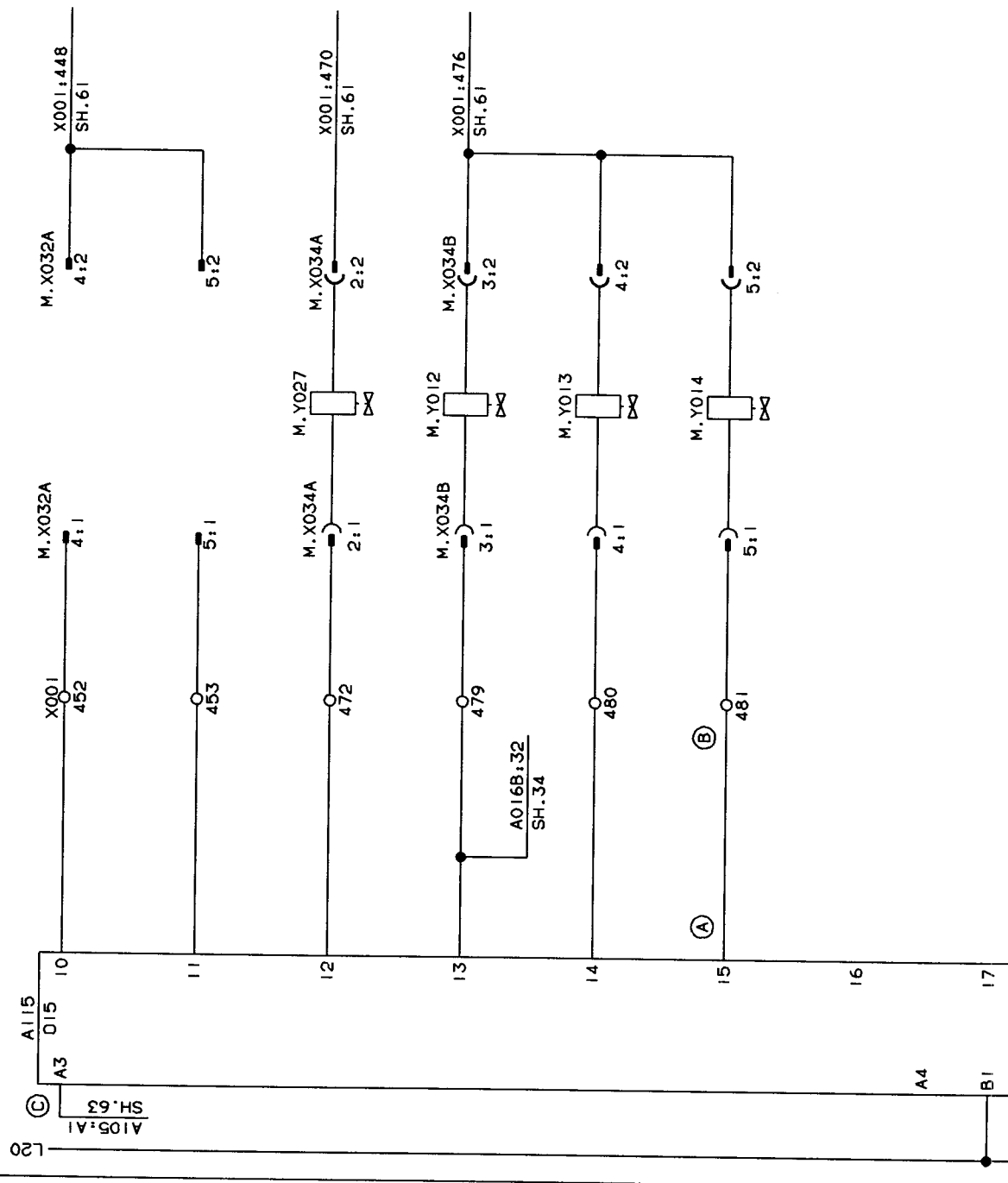

INTRODUCED WITH AM. NO.	19260	DATE:	930310	STOR.	HK/UTH	DESCRIPTION:	PLC-OUT, VALVES
TABLE	A	AM. NO.	20080	DATE	930909	MACHINE:	TBA/9-1401 S.A
DATE	930909	STOR.	HK/MRI	DRAWING REMARKS			
							44093-64:01

This drawing must not, without the consent of Tetra Pak, be copied, transmitted or disclosed to any third party.

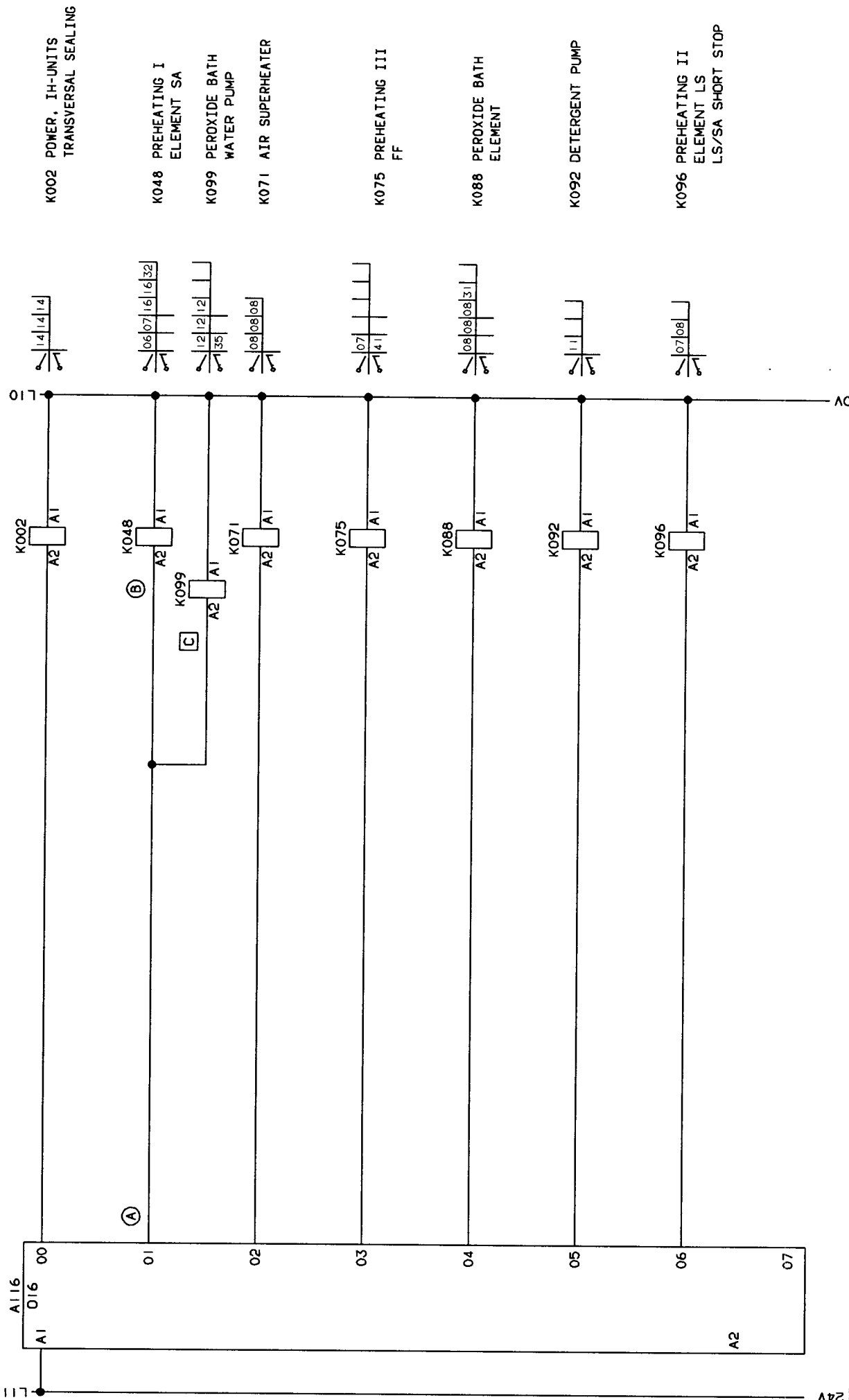

K002 POWER, IH-UNITS  
TRANSVERSAL SEALING

K048 PREHEATING I  
ELEMENT SA

K099 PEROXIDE BATH  
WATER PUMP

K071 AIR SUPERHEATER

K075 PREHEATING III  
FF

K088 PEROXIDE BATH  
ELEMENT

K092 DETERGENT PUMP

K096 PREHEATING II  
ELEMENT LS  
LS/SA SHORT STOP

INTRODUCED WITH AM NO.	19260	DATE	930310	BY	HK/JUTH
ISSUE					
AM NO.					
DATE					
BY					
ALTERNATIONS ONLY IN CADAM					
DESCRIPTION:				PLC-OUT, CONTACTORS	
MACHINE:				TBA/9-1401 S.A	
				DRAWING NO. 44093-65:01	

This drawing must not without the consent of Tetra Pak be copied, transmitted or disclosed to any third party.

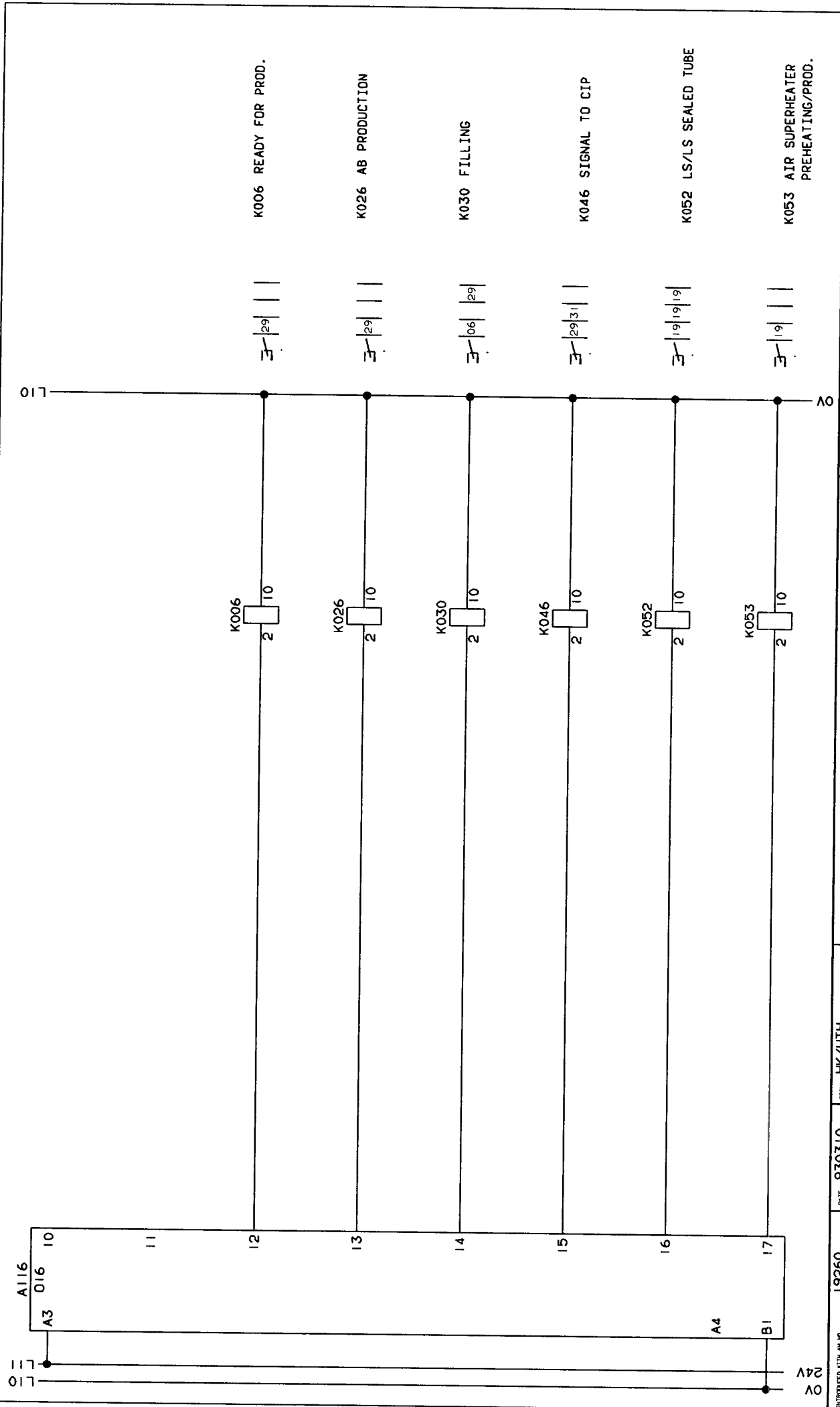

K006 READY FOR PROD.

K026 AB PRODUCTION

K030 FILLING

K046 SIGNAL TO CIP

K052 LS/LS SEALED TUBE

K053 AIR SUPERHEATER  
PREHEATING/PROD.

INTRODUCED WITH AM. NO.	19260	DATE	930310	BY	HK/UTH
TABLE NO.					
DATE					
BY					
DESCRIPTION: PLC-OUT, RELAYS					
MACHINE: TBA/9-1401 S.A					
DRAWING REMARKS					
44093-66:01					

ALTERATIONS ONLY IN CADAM

This drawing must not without the consent of Tetra Pak be copied, transmitted or disclosed to any third party.

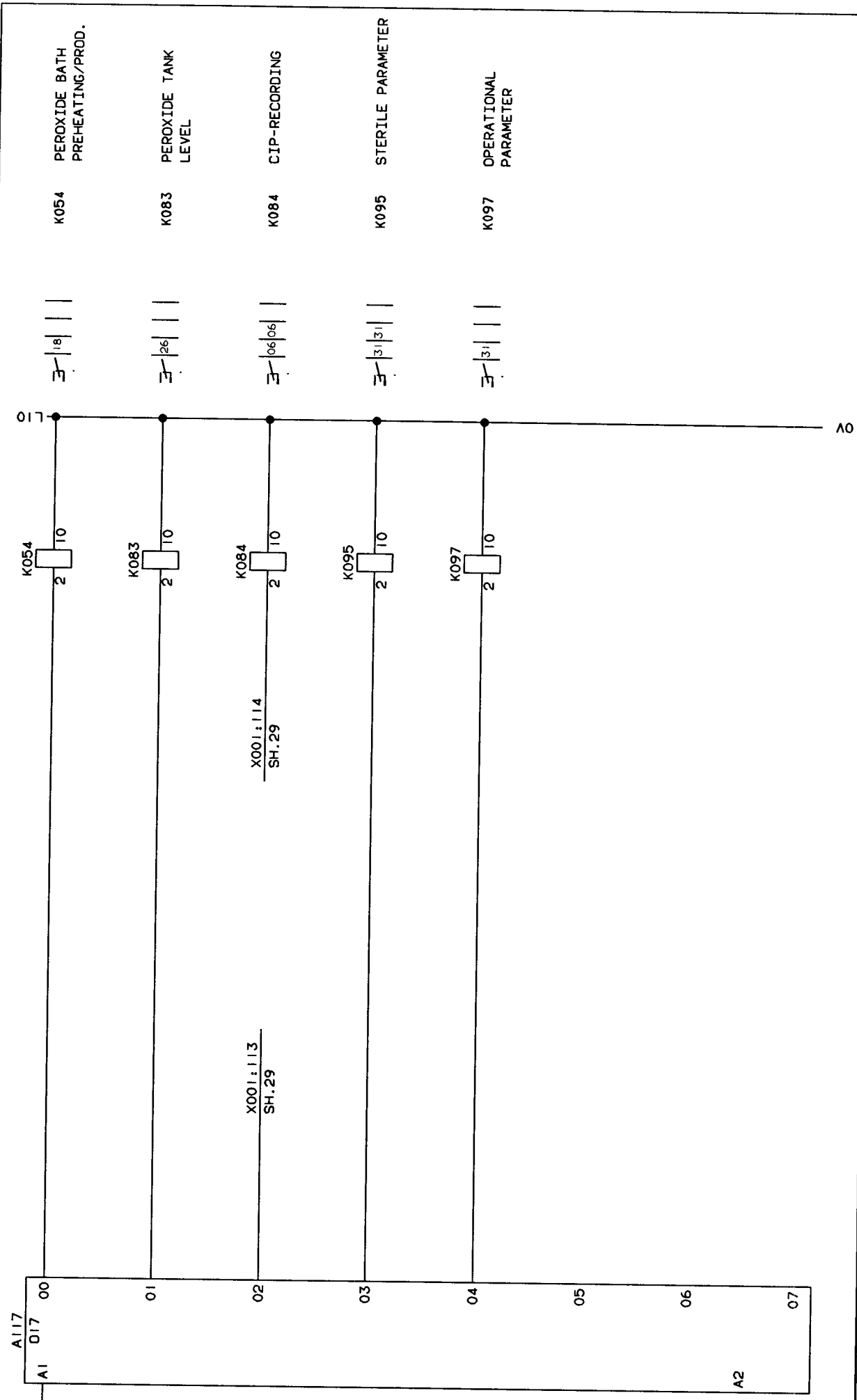

INTRODUCTION BY AM NO.	19260	DATE	930310	SIGN.	HK/UJH
ISSUE					
AM NO.					
DATE					
SIGN.					
ALTERATIONS ONLY IN CADAM					
DESCRIPTION: PLC-OUT, RELAYS				MACHINE: TBA/9-140   S.A	
				DRAWING NO: 44093-67:01	

This drawing must not without the consent of Tetra Pak be copied, transmitted or disclosed to any third party.

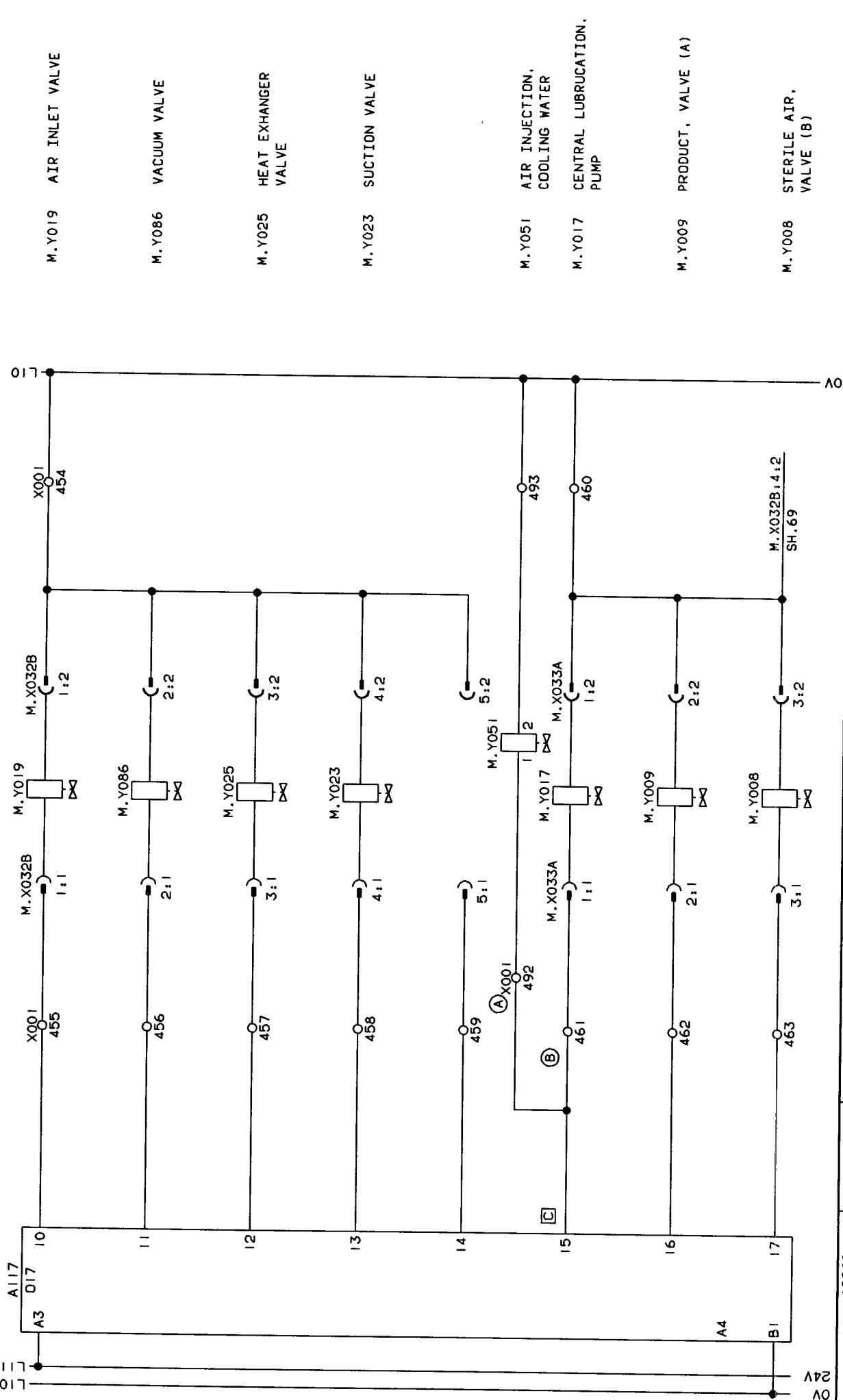

- M.Y019 AIR INLET VALVE
- M.Y086 VACUUM VALVE
- M.Y025 HEAT EXCHANGER VALVE
- M.Y023 SUCTION VALVE
- M.Y051 AIR INJECTION, COOLING WATER
- M.Y017 CENTRAL LUBRICATION, PUMP
- M.Y009 PRODUCT, VALVE (A)
- M.Y008 STERILE AIR, VALVE (B)

INTRODUCED WITH AM. NO.	19260	DATE	930310	BY	HK/JUTH
ISSUE	A	AM. NO.	20080	DATE	930909
BY	HK/MRI	DATE	930909	BY	HK/MRI
DESCRIPTION: PLC-OUT, VALVES					
MACHINE: TBA/9-1401 S.A					
DRAWING REMARKS					
ALTERATIONS ONLY IN COLOM					
44093-68:01					

This drawing must not without the consent of Tetra Pak be copied, transmitted or disclosed to any third party.

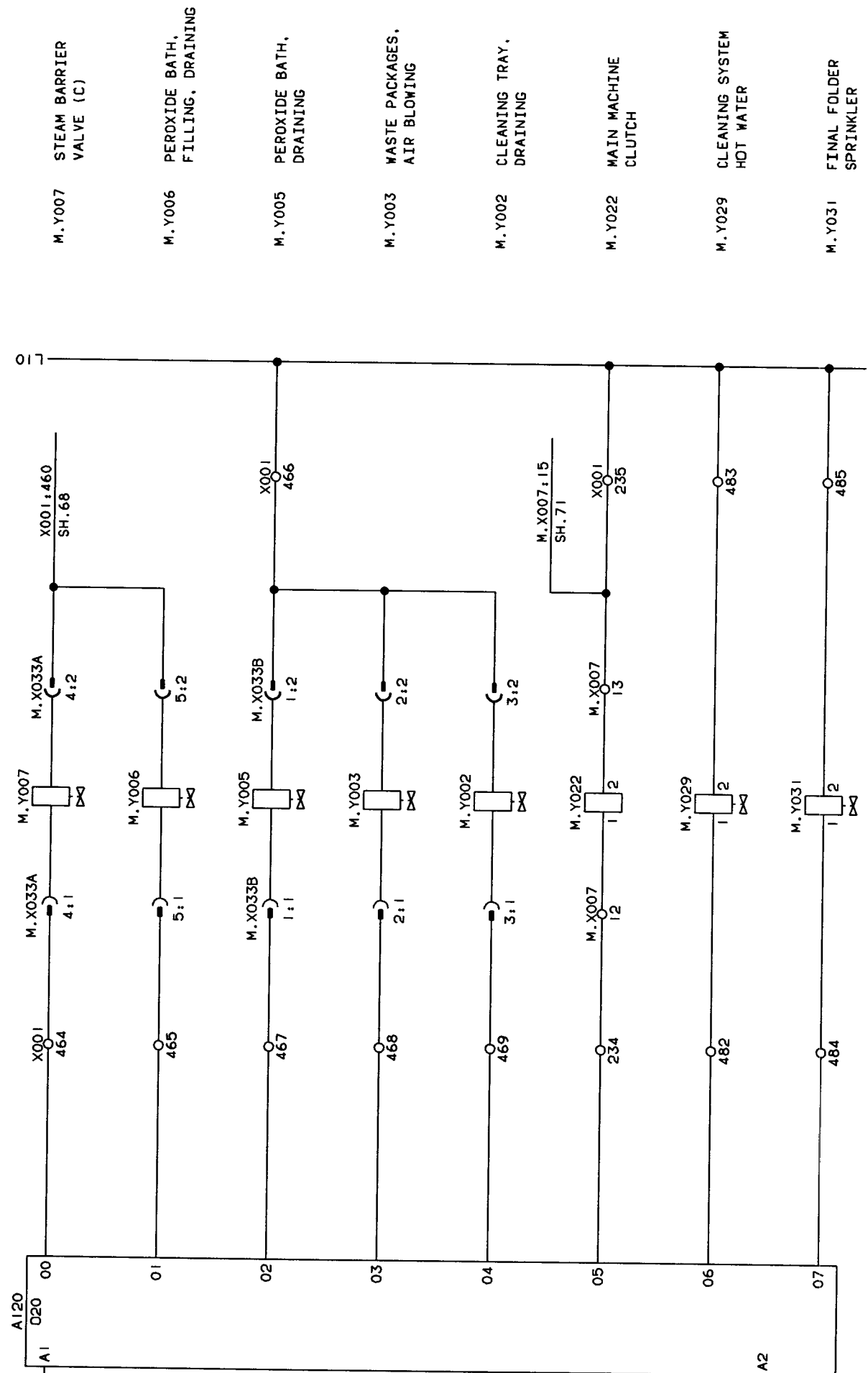

M.Y007	STEAM BARRIER VALVE (C)
M.Y006	PEROXIDE BATH, FILLING, DRAINING
M.Y005	PEROXIDE BATH, DRAINING
M.Y003	WASTE PACKAGES, AIR BLOWING
M.Y002	CLEANING TRAY, DRAINING
M.Y022	MAIN MACHINE CLUTCH
M.Y029	CLEANING SYSTEM HOT WATER
M.Y031	FINAL FOLDER SPRINKLER

INTRODUCED WITH AM NO.	DATE	930310	SIGN.	HK/JUTH
ISSUE				
AM NO.				
DATE				
SIGN.				
ALTERATIONS ONLY IN CADD				
DESCRIPTION: PLC-OUT, VALVES				MACHINE: TBA/9-1401 S.A
				44093-69:01

This drawing must not without the consent of Tetra Pak, be copied, transmitted or disclosed to any third party.

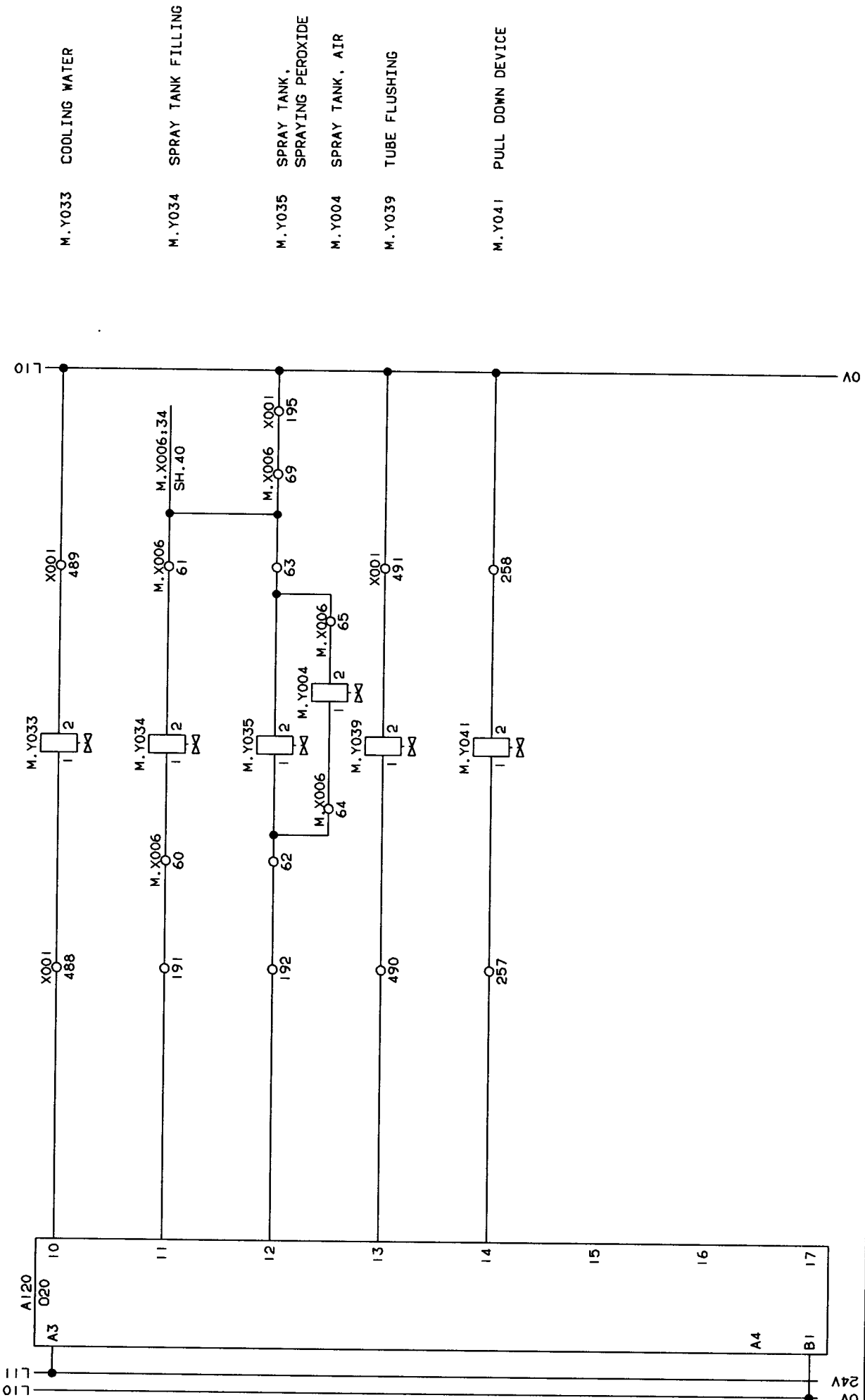

INTRODUCED BY: AM NO.	DATE: 19260	BY: 930310	CHK/UTH	DESCRIPTION: PLC-OUT, VALVES
ISSUE				
AM NO.				
DATE				
BY				
BY				MACHINE: TBA/9-1401 S.A
ALTERATIONS ONLY IN CADAM				MACHINE: 44093-70:01

This drawing must not without the consent of Tetra Pak be copied, transmitted or disclosed to any third party.

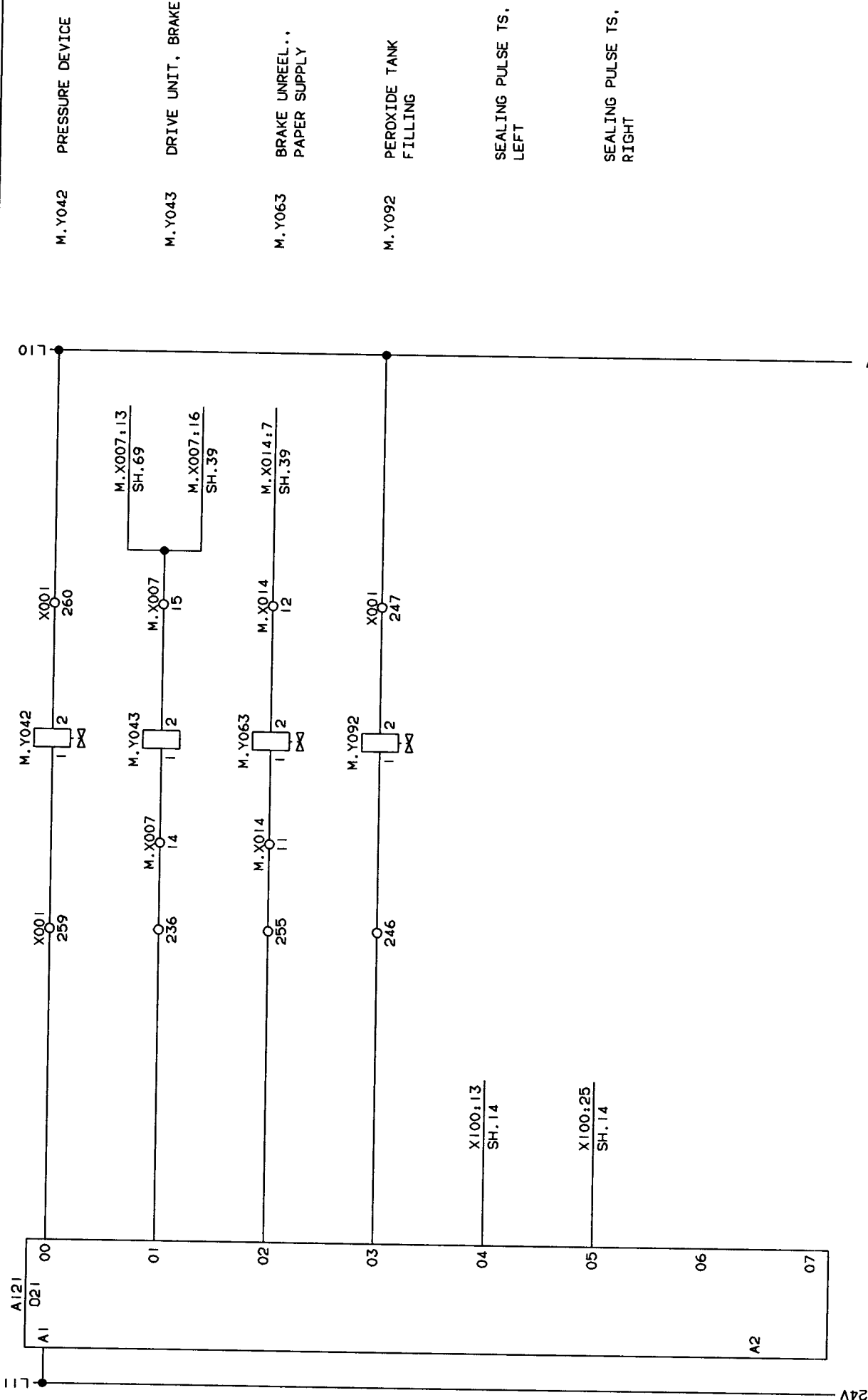

INTRODUCED BY: AM. NO.	19260	DATE:	930310	SIGN.	HK/JUTH
TITLE					
AM. NO.					
DATE					
SIGN.					
ALTERATIONS ONLY IN COLUMN					
				DESCRIPTION:	PLC-OUT, VALVES
				MACHINE:	TBA/9-1401 S.A
					44093-71:01

This drawing must not without the consent of Tetra Pak be copied, transmitted or disclosed to any third party.

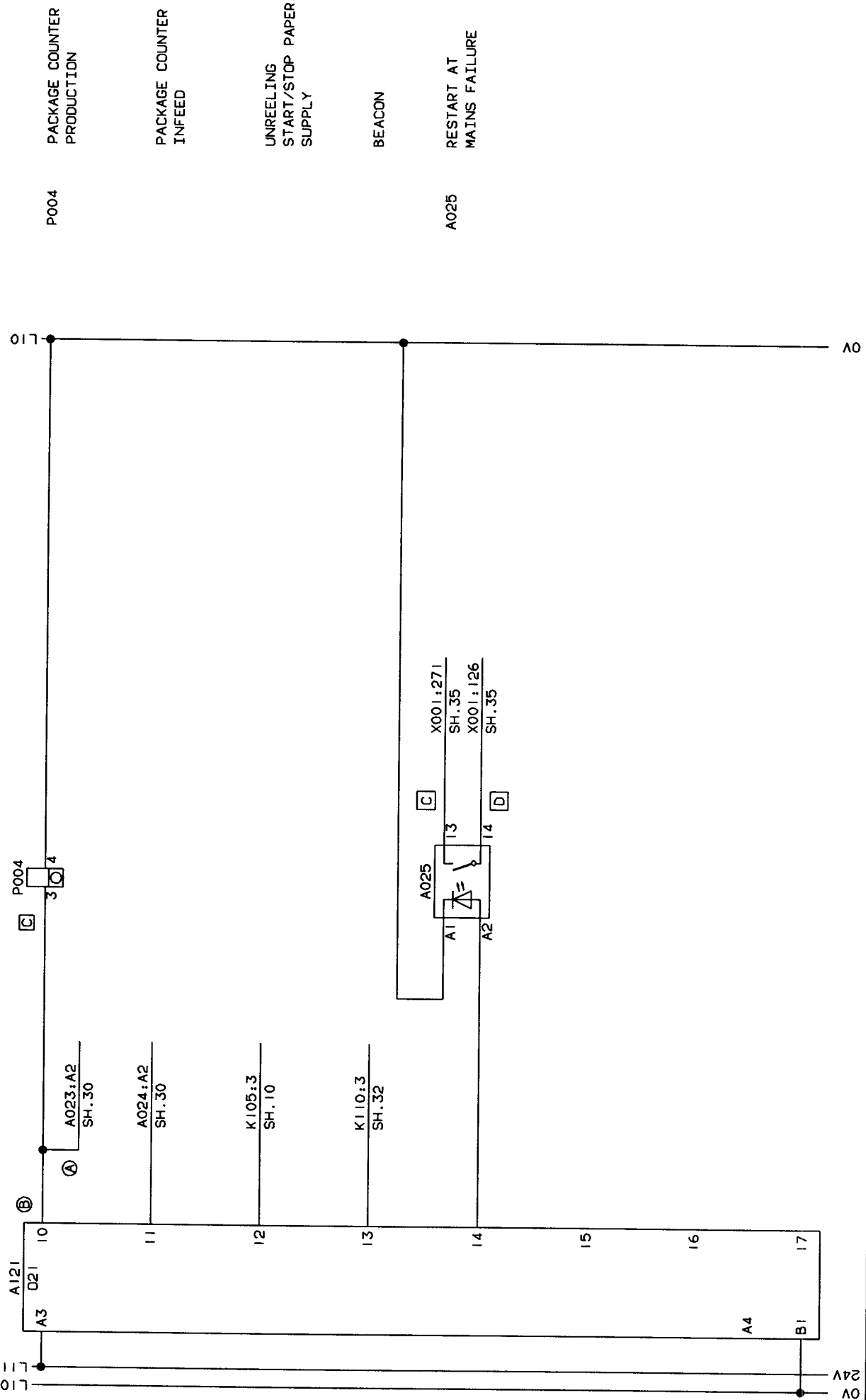

P004 PACKAGE COUNTER PRODUCTION  
 PACKAGE COUNTER INFEEED  
 UNREELING START/STOP PAPER SUPPLY  
 BEACON  
 A025 RESTART AT MAINS FAILURE

INTRODUCED BY: A	DATE: 19260	BY: 930310	CHK/UTH	DESCRIPTION: PLC-OUT
REV: 20080				
DATE: 930909				
BY: HK/MRI				
ALTERATIONS ONLY IN CADAM				MACHINE: TBA/9-1401 S.A
				DRAWING REMARKS
				44093-72:01

This drawing must not without the consent of Tetra Pak, be copied, transmitted or disclosed to any third party.

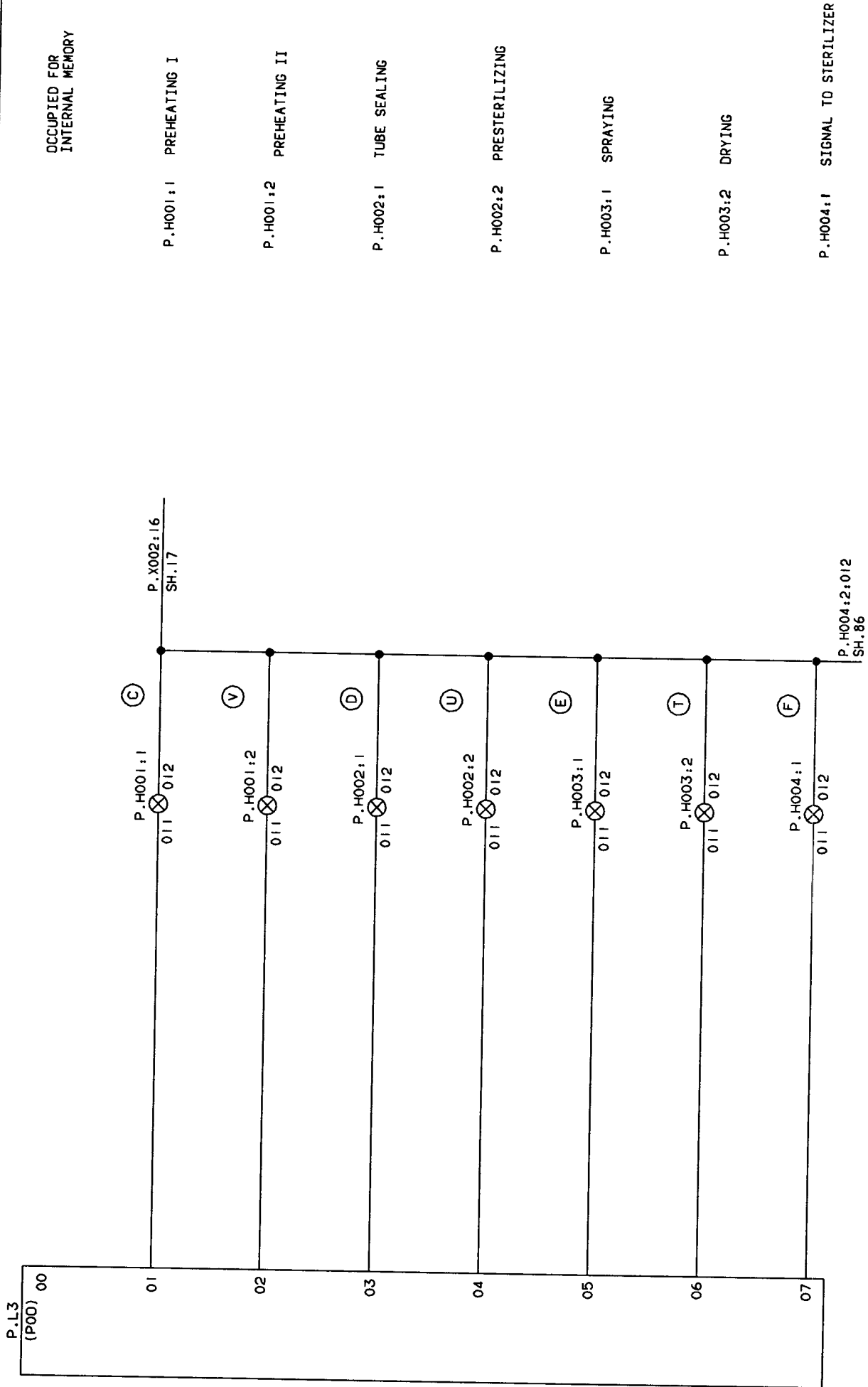

INTRODUCED WITH AM NO.	DATE	930310	BY	HK/UTH
ISSUE				
AM NO.				
DATE				
BY				
ALTERATIONS ONLY IN CADAM				
DRAWING REMARKS				
DESCRIPTION:			PANEL INTERFACE OUT	
MACHINE:			TBA/9-1401 S.A	
			44093-85:01	

This drawing must not without the consent of Tetra Pak be copied, transmitted or disclosed to any third party.

P.H004:1:012  
SH.85

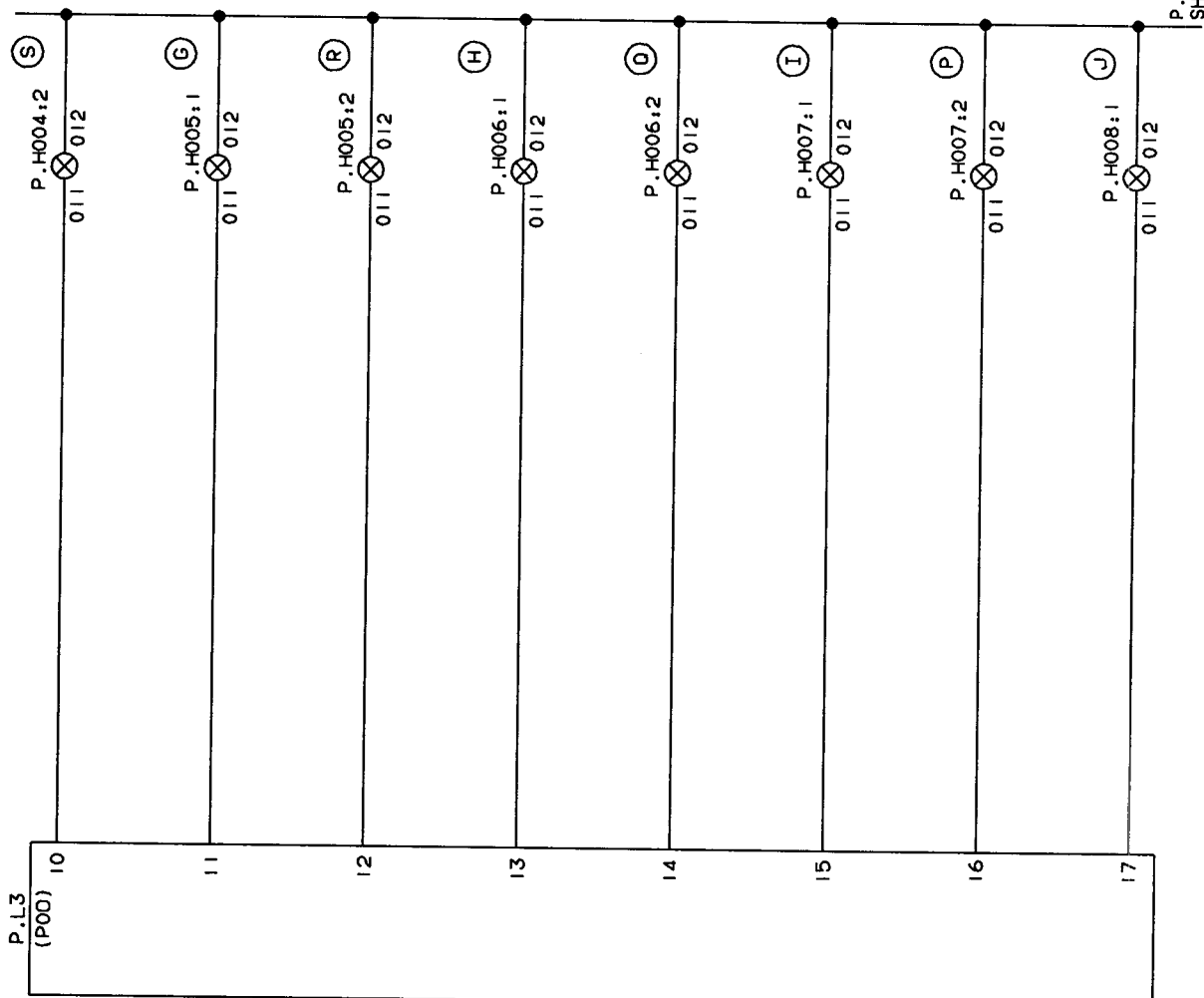

- P.H004:2 SIGNAL FROM STERILIZER
- P.H005:1 START SEQUENCE
- P.H005:2 DRIVE MOTOR ON
- P.H006:1 FILLING
- P.H006:2 PRODUCTION
- P.H007:1 NO PRODUCTION ALLOWED
- P.H007:2 PRODUCTION FINISHED
- P.H008:1 WORK ENVIRONMENT ASEPTIC CHAMBER ON

INTRODUCED BY: AN. NO.	19260	DATE:	930310	BY:	HK/UTH
ISSUE					
AN. NO.					
DATE					
BY:					
ALTERATIONS ONLY IN CADAM					
DESCRIPTION:				PANEL INTERFACE OUT	
MACHINE:				TBA/9-1401 S.A	
DRAWING REMARKS:				44093-86:01	

This drawing must not without the consent of Tetra Pak be copied, transmitted or disclosed to any third party.

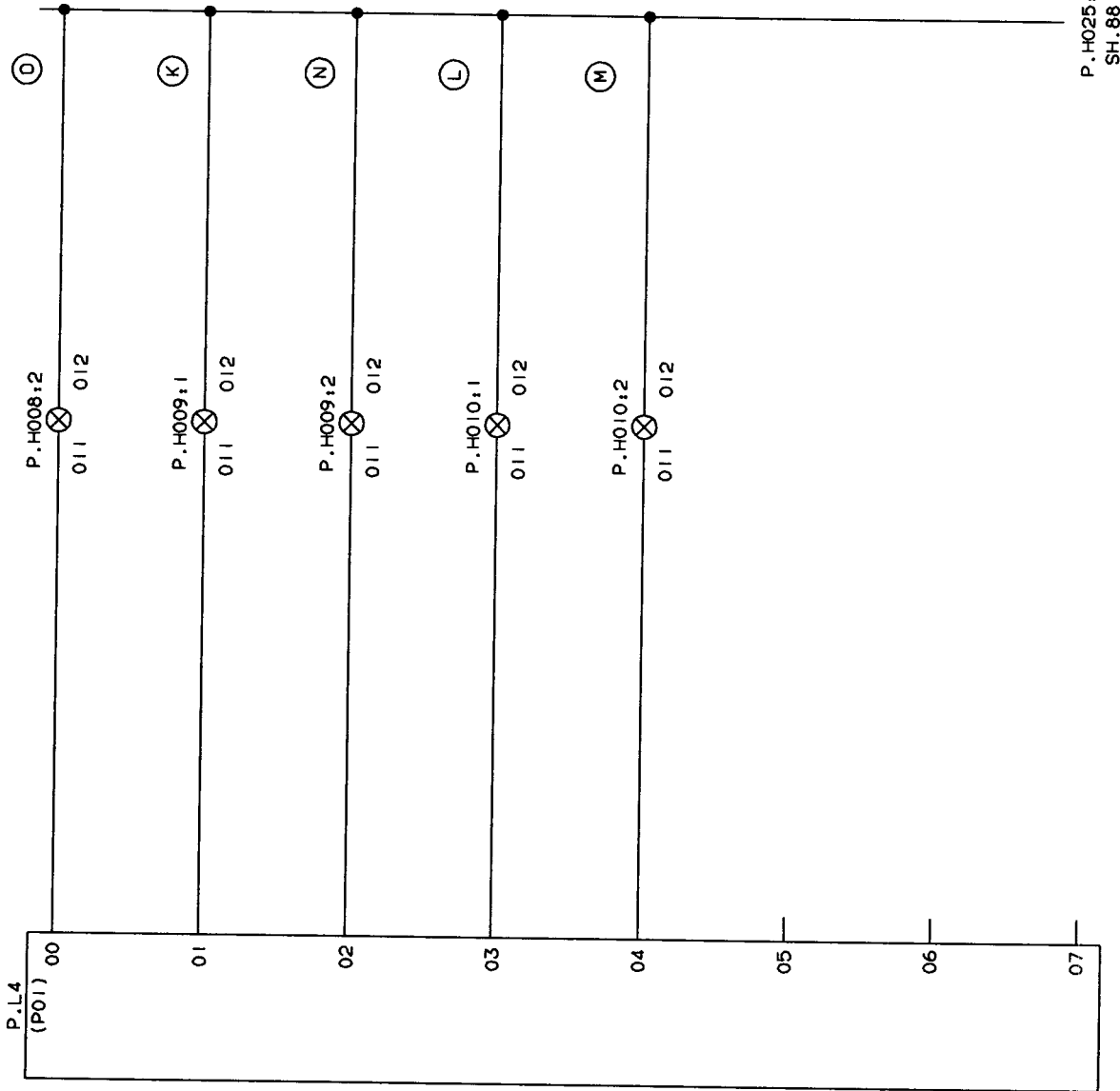

P.H008:1:012  
SH.86

P.H025:12  
SH.88

P.H008:2 WEAC READY FOR DOOR OPENING

P.H009:1 PREPARATION FOR MACHINE

P.H009:2 PREPARATION FOR CLEANING OF VALVE

P.H010:1 CLEANING MACHINE

P.H010:2 CLEANING VALVE

INTENDED BY AM. NO.	19260	DATE	930310	EDN.	HK/LJTH
DESIGN					
AM. NO.					
DATE					
EDN.					
ALTERATIONS ONLY IN CADAM					
DESCRIPTION: PANEL INTERFACE OUT				MACHINE: TBA/9-1401 S.A	
				44093-87:01	



This drawing must not without the consent of Tetra Pak be copied, transmitted or disclosed to any third party.

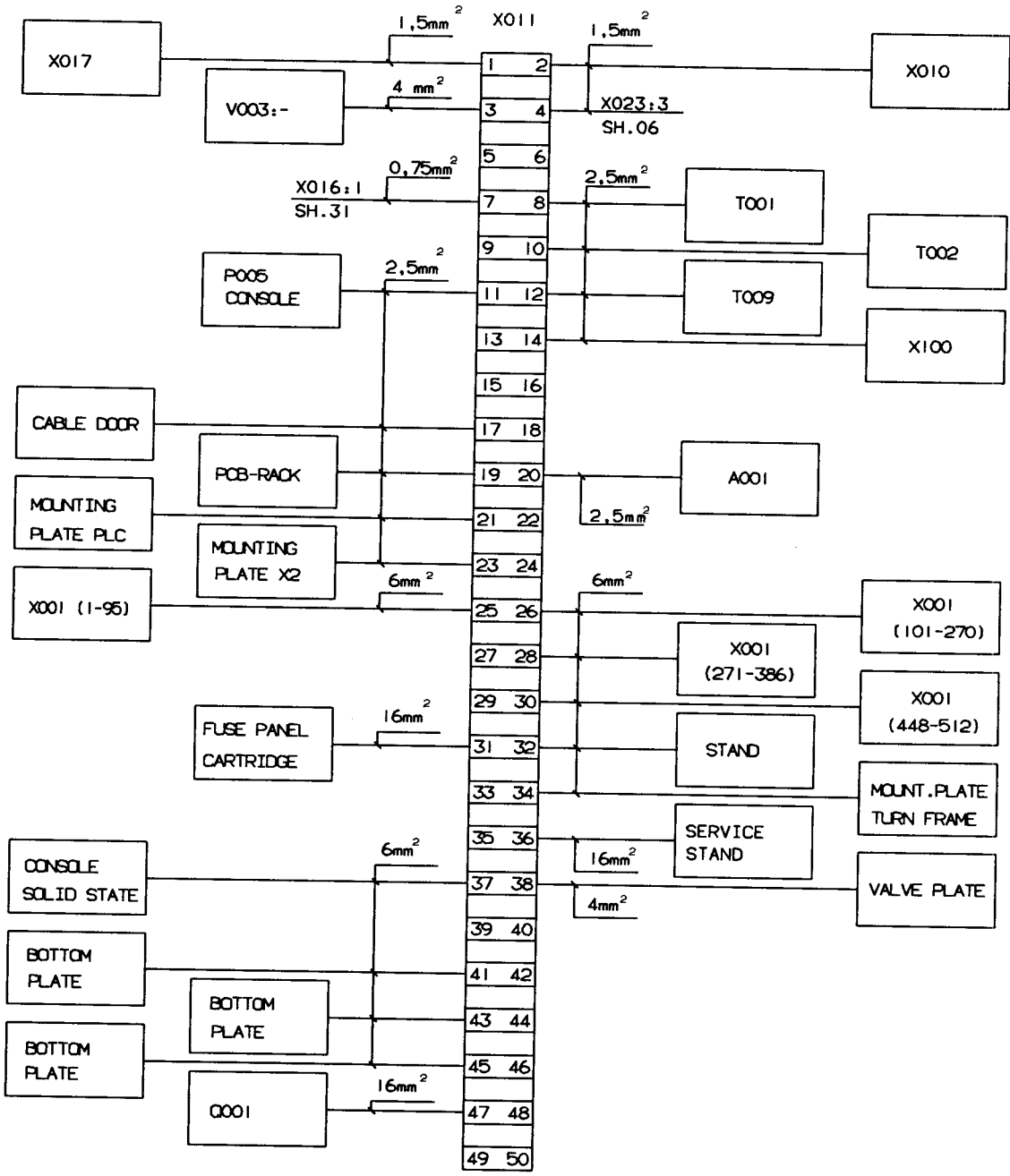

INTRODUCED BY/AM NO.	DATE	930310	BY	HK/LJH
TITLE				
AM NO.				
DATE				
BY				
ALTERATIONS ONLY IN CADAM				
DESCRIPTION: GROUND CONNECTION CONTROL CABINET			MACHINE: TBA/9-1401 S.A	
			44093-89:01	

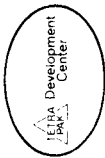

LINE SUMMARY "0"

Date: 93-09-15

Machine: 649205

ECN 19260 '0' ECN 20080 '0'  
19930317 HK 19930915 HK

Line	Position	Sheet Area Colour	Line	Position	Sheet Area Colour
L1	XL1,1	25 BK		F056B,2	14:01
	Q002,6	05:01		F202,2	07:01
L1	XL1,2	25 BK	L2	XL2,4	25 BK
	Q003,1	10:01		F008,2	07:01
	Q012,1	16:01		F019,2	16:01
	Q087,1	10:01			
	Q098,1	10:01	L3	XL3,1	25 BK
				Q002,2	05:01
L1	XL1,3	25 BK			
	F010,2	08:01	L3	XL3,2	25 BK
	F028A,2	08:01		Q003,5	10:01
	F029A,2	08:01		Q012,5	16:01
	F056A,2	14:01		Q087,5	10:01
				Q098,5	10:01
L1	XL1,4	25 BK			
	F001,2	06:01	L3	XL3,3	25 BK
L2	XL2,1	25 BK		F028C,2	08:01
	Q002,4	05:01		F029C,2	08:01
				F056C,2	14:01
L2	XL2,2	25 BK			
	Q003,3	10:01	L3	XL3,4	25 BK
	Q012,3	16:01		F005,2	07:01
	Q087,3	10:01			
	Q098,3	10:01	L10	XL10,1	0.75 BU
				V003,-	16:01
				X011,3	16:01
L2	XL2,3	25 BK			
	F028B,2	08:01	L10	XL10,2	0.75 BU
	F029B,2	08:01		X016,4	31:01

Based on ECN: 20080

LINE SUMMARY 4- 44093-90:01

Sheet: 1  
Cont: 2



LINE SUMMARY "0"

Date: 93-09-15

Machine: 649205

ECN 19260 '0' ECN 20080 '0'  
19930317 HK 19930915 HK

Line	Position	Sheet Area Colour	Line	Position	Sheet Area Colour
L10	X016,6	31:01		A002,A2	35:01
	,8	31:01		,23	35:01
	A016B,24	34:01	L10	XL10,8	0.75 BU
	,18	34:01		K097,10	67:01
	A016A,1	34:01		K095,10	67:01
	A001,25	11:01		K084,10	67:01
	P004,4	72:01		K083,10	67:01
L10	XL10,3	0.75 BU		K054,10	67:01
	X100,9	14:01		K053,10	66:01
	,23	14:01	L10	XL10,9	0.75 BU
L10	XL10,4	0.75 BU		K052,10	66:01
	K110,4	32:01		K046,10	65:01
	K106,4	10:01		K036,10	32:01
L10	XL10,5	0.75 BU		K030,10	66:01
	K075,A1	65:01		K026,10	65:01
	K071,A1	65:01		K006,10	66:01
	K048,A1	65:01	L10	XL10,10	0.75 BU
	K002,A1	65:01		X009,2	32:01
L10	XL10,6	0.75 BU		A023,A1	30:01
	K099,A1	65:01		A024,A1	30:01
	K096,A1	65:01		A025,A1	72:01
	K092,A1	65:01	L10	XL10,11	0.75 BU
	K088,A1	65:01		X001,118	30:01
L10	XL10,7	0.75 BU		,156	32:01
	K003,A1	35:01		,169	45:01
				,195	70:01

Based on ECN: 20080

LINE SUMMARY 4- 44093-90:01

Sheet: 2  
Cont: 3



LINE SUMMARY "0"

Date: 93-09-15

Machine: 649205

ECN 19260 '0' ECN 20080 '0'  
19930317 HK 19930915 HK

Line	Position	Sheet Area Colour	Line	Position	Sheet Area Colour
L10	X001,228	36:01	L10	XL10,23	0.75 BU
	,235	69:01		A101,B2	36:01
	,247	71:01			
L10	XL10,12	0.75 BU	L10	XL10,25	0.75 BU
	X001,249	32:01		A103,B1	39:01
	,250	39:01		,B2	40:01
	,258	70:01	L10	XL10,26	0.75 BU
	,260	71:01		A104,B1	41:01
	,262	17:01		,B2	42:01
	,279	39:01	L10	XL10,27	0.75 BU
L10	XL10,14	0.75 BU		A105,B1	43:01
	X001,454	68:01		,B2	44:01
	,460	68:01	L10	XL10,28	0.75 BU
	,466	69:01		A106,B1	45:01
L10	XL10,15	0.75 BU		,B2	46:01
	X001,483	69:01	L10	XL10,36	0.75 BU
	,485	69:01		A116,B1	66:01
	,489	70:01	L10	XL10,37	0.75 BU
	,491	70:01		A117,B1	68:01
	,493	68:01	L10	XL10,38	0.75 BU
L10	XL10,20	0.75 BU		A120,B1	70:01
	XL10,21	16:01	L10	XL10,39	0.75 BU
L10	XL10,22	0.75 BU		A121,B1	72:01
	G100,B1	17:01			

Based on ECN: 20080

LINE SUMMARY 4- 44093-90:01

Sheet: 3  
Cont: 4



LINE SUMMARY "0"

Date: 93-09-15

Machine: 649205

ECN 19260 '0' ECN 20080 '0'  
19930317 HK 19930915 HK

Line	Position	Sheet Area Colour	Line	Position	Sheet Area Colour
L11	XL11,1 F055A,2	0.75 BU 16:01		,23 A004,23	18:01 18:01
L11	XL11,2 X001,102 ,120 ,153 ,157 ,167 ,227	0.75 BU 29:01 30:01 29:01 41:01 40:01 36:01	L11	XL11,7 A015,18 A017,18 A018,18 A019,18 A022,18	0.75 BU 24:01 24:01 25:01 25:01 26:01
L11	XL11,4 X001,238 ,241 ,252 ,261 ,281 ,290 ,292	0.75 BU 39:01 41:01 39:01 17:01 39:01 41:01 41:01	L11	XL11,8 K077,13 A450,11 A451,11 A002,A1 ,13 ,33 ,41 K097,3 K095,3	0.75 BU 31:01 27:01 27:01 35:01 35:01 35:01 35:01 31:01 31:01
L11	XL11,6 A202,23 A030,23 A014,23 A013,23 A010,19 ,23 A008,19 ,23 A006,19	0.75 BU 21:01 21:01 20:01 20:01 19:01 19:01 19:01 19:01 18:01	L11	XL11,18 XL11,21  XL11,23 A116,A1 ,A3  XL11,24 A117,A1	0.75 BU 16:01  0.75 BU 65:01 66:01  0.75 BU 67:01

Based on ECN: 20080

LINE SUMMARY 4- 44093-90:01

Sheet: 4  
Cont: 5



LINE SUMMARY "0"

Date: 93-09-15

Machine: 649205

ECN 19260 '0' ECN 20080 '0'  
19930317 HK 19930915 HK

Line	Position	Sheet Area Colour	Line	Position	Sheet Area Colour
L11	A117,A3	68:01	L12	XL12,22 G100,A1	0.75 BU 17:01
L11	XL11,25 A120,A1 ,A3	0.75 BU 69:01 70:01	L12	XL12,23 A101,A2	0.75 BU 36:01
L11	XL11,26 A121,A1 ,A3	0.75 BU 71:01 72:01	L13	XL13, K048,6 X001,248 A016A,10 ,14 A016B,17	0.75 BU 16:01 32:01 34:01 34:01 34:01
L12	XL12,1 F055B,4	0.75 BU 16:01	L20	XL20,1 A002,24	0.75 BU 35:01
L12	XL12,2 S003,5	0.75 BU 40:01	L20	XL20,2 K201,A1 K098,A1 K094,A1 K093,A1 K091,A1 K087,A1 K082,A1 K081,A1 K077,A1 K051,A1 K014,A1	0.75 BU 41:01 0.75 BU 32:01 62:01 62:01 62:01 63:01 62:01 63:01 62:01 63:01 63:01 63:01
L12	XL12,3 Q087,14	0.75 BU 41:01	L20	XL20,3	0.75 BU
L12	XL12,4 X100,10 ,11 ,12 ,24	0.75 BU 14:01 14:01 14:01 14:01			
L12	XL12,5 F003,LIV	0.75 BU 32:01			
L12	XL12,15 XL12,21	0.75 BU 16:01			

Based on ECN: 20080

LINE SUMMARY 4- 44093-90:01

Sheet: 5  
Cont: 6



LINE SUMMARY "0"

Date: 93-09-15

Machine: 649205

ECN 19260 '0' ECN 20080 '0'  
19930317 HK 19930915 HK

Line	Position	Sheet Area Colour	Line	Position	Sheet Area Colour
L20	X001,448	62:01		A114,A3	62:01
	,470	61:01			
	,476	61:01	L50	XL50,1	0.75 RD
	,487	62:01		X003,19	16:01
L20	XL20,4	0.75 BU	L50	XL50,2	0.75 RD
	A102,B1	37:01		A451,A2	27:01
	,B2	38:01		A450,A2	27:01
	A114,B1	62:01			
	A115,B1	64:01	L50	XL50,11	0.75 RD
L20	XL20,11			A202,27	21:01
	P002,A"-	63:01		A030,27	21:01
				A014,27	20:01
L20	XL20,12	0.75 BU		A013,27	20:01
	X009,4	32:01		A010,27	19:01
				A008,27	19:01
L21	XL21,	0.75 BU		A006,27	18:01
	A002,34	35:01		A004,27	18:01
	Q201,14	37:01		A015,A2	24:01
	X001,121	37:01		A017,A2	24:01
	,159	37:01		A018,A2	25:01
	,275	37:01		A019,A2	25:01
	,503	38:01		A022,A2	26:01
	,506	38:01		X016,3	31:01
	,508	38:01			
	,510	38:01	L50	XL50,12	0.75 RD
	,512	38:01		X100,5	14:01
	S002,13	37:01		,7	14:01
	S004,13	38:01		,21	14:01

Based on ECN: 20080

LINE SUMMARY

4- 44093-90:01

Sheet: 6  
Cont: 7



LINE SUMMARY

Date: 93-09-15

Machine: 649205

ECN 19260 '0' ECN 20080 '0'  
19930317 HK 19930915 HK

Line	Position	Sheet Area Colour	Line Position	Sheet Area Colour
L51	XL51,1	0.75 RD		14:01
	F019,1	16:01	,22	
	K048,13	16:01		
L51	XL51,2	0.75 RD		
	K088,13	31:01		
	A450,A1	27:01		
	A451,A1	27:01		
	K046,6	31:01		
	K095,6	31:01		
L51	XL51,11	0.75 RD		
	A202,26	21:01		
	A030,26	21:01		
	A014,26	20:01		
	A013,26	20:01		
	A010,26	19:01		
	A008,26	19:01		
	A006,26	18:01		
	A004,26	18:01		
	A015,A1	24:01		
	A017,A1	24:01		
	A018,A1	25:01		
	A019,A1	25:01		
	A022,A1	26:01		
L52	XL52,	0.75 RD		
	K048,14	16:01		
	X100,6	14:01		
	,8	14:01		

Based on ECN: 20080

LINE SUMMARY 4- 44093-90:01

Sheet: 7  
Cont: -



TERMINAL SUMMARY "A"

Date: 93-03-17

Machine: 649205

FCN 19260 \*0\*  
19930317 HK

Position	Sheet	Position	Sheet	Position	Sheet	Position	Sheet	Position	Sheet
XL10,21	16:01	X001,25	11:01	X001,55	07:01	X001,85	07:01	X001,85	
		,26	11:01	,56	08:01	,86	08:01	,86	
XL11,21	16:01	,27	11:01	,57	08:01	,87	08:01	,87	
		,28	10:01	,58	07:01	,88	07:01	,88	
XL12,21	16:01	,29	10:01	,59	07:01	,89	07:01	,89	
		,30	10:01	,60	06:01	,90	06:01	,90	
X001,1	07:01	,31	10:01	,61	06:01	,91	06:01	,91	
,2	07:01	,32	10:01	,62	06:01	,92	06:01	,92	
,3	07:01	,33	10:01	,63	06:01	,93	06:01	,93	
,4	07:01	,34	11:01	,64	06:01	,94	06:01	,94	
,5	08:01	,35	11:01	,65	06:01	,95	06:01	,95	
,6	08:01	,36	11:01	,66	06:01	,101	06:01	,101	29:01
,7	08:01	,37	10:01	,67	06:01	,102	06:01	,102	29:01
,8	08:01	,38	10:01	,68	06:01	,103	06:01	,103	29:01
,9	08:01	,39	10:01	,69		,104		,104	29:01
,10	08:01	,40	10:01	,70		,105		,105	29:01
,11	12:01	,41	10:01	,71		,106		,106	29:01
,12	12:01	,42	10:01	,72		,107		,107	29:01
,13	12:01	,43	12:01	,73		,108		,108	29:01
,14	12:01	,44	12:01	,74		,109		,109	29:01
,15	12:01	,45	12:01	,75		,110		,110	29:01
,16	12:01	,46	13:01	,76		,111		,111	29:01
,17	11:01	,47	13:01	,77		,112		,112	29:01
,18	11:01	,48	13:01	,78		,113		,113	29:01
,19	11:01	,49	11:01	,79		,114		,114	29:01
,20	11:01	,50	11:01	,80		,115		,115	37:01
,21	12:01	,51	07:01	,81		,116		,116	37:01
,22	12:01	,52	07:01	,82		,117		,117	45:01
,23	12:01	,53		,83		,118		,118	30:01
,24		,54	07:01	,84		,119		,119	30:01

Based on FCN: 19260

TERMINAL SUMMARY 4- 44093-91:01

Sheet: 1  
Cont: 2



TERMINAL SUMMARY "A"

Date: 93-03-17

Machine: 649205

ECN 19260 \*G\*  
19930317 HK

Position	Sheet	Position	Sheet	Position	Sheet	Position	Sheet	Position	Sheet
X001,120	30:01	X001,150	20:01	X001,180	40:01	X001,210	34:01		
,121	37:01	,151	20:01	,181		,211	34:01		
,122	37:01	,152	20:01	,182		,212	34:01		
,123	35:01	,153	29:01	,183		,213	34:01		
,124	35:01	,154	29:01	,184	25:01	,214	34:01		
,125	35:01	,155	32:01	,185	25:01	,215	34:01		
,126	35:01	,156	32:01	,186	25:01	,216	26:01		
,127	30:01	,157	41:01	,187	25:01	,217	26:01		
,128	30:01	,158	41:01	,188	24:01	,218	26:01		
,129	30:01	,159	37:01	,189	24:01	,219	36:01		
,130	30:01	,160	37:01	,190	24:01	,220	36:01		
,131	30:01	,161	41:01	,191	70:01	,221	36:01		
,132	30:01	,162	41:01	,192	70:01	,222	36:01		
,133	24:01	,163	35:01	,193		,223	36:01		
,134	24:01	,164	35:01	,194		,224	36:01		
,135	21:01	,165	35:01	,195	70:01	,225	36:01		
,136	21:01	,166	35:01	,196		,226	36:01		
,137	21:01	,167	40:01	,197		,227	36:01		
,138	21:01	,168		,198		,228	36:01		
,139	19:01	,169	45:01	,199		,229	37:01		
,140	19:01	,170	45:01	,200		,230	37:01		
,141	19:01	,171		,201		,231	37:01		
,142	19:01	,172	40:01	,202		,232			
,143	18:01	,173	40:01	,203		,233			
,144	18:01	,174	40:01	,204		,234	69:01		
,145	19:01	,175	40:01	,205		,235	69:01		
,146	19:01	,176	40:01	,206	34:01	,236	71:01		
,147	18:01	,177	45:01	,207	34:01	,237	39:01		
,148	18:01	,178	45:01	,208	34:01	,238	39:01		
,149	20:01	,179		,209	34:01	,239			

Based on ECN: 19260

TERMINAL SUMMARY 4- 44093-91:01

Sheet: 2  
Cont: 3



Machine: 649205

ECN 19260 '0'  
19930317 HK

Position	Sheet	Position	Sheet	Position	Sheet	Position	Sheet
X001,240		X001,270	35:01	X001,300		X001,330	
,241	41:01	,271	35:01	,301		,331	
,242	41:01	,272	35:01	,302		,332	
,243		,273		,303		,333	
,244		,274		,304		,334	
,245		,275	37:01	,305		,335	
,246	71:01	,276	37:01	,306		,336	
,247	71:01	,277	37:01	,307		,337	
,248	32:01	,278	37:01	,308		,338	
,249	32:01	,279	39:01	,309		,339	
,250	39:01	,280	39:01	,310		,340	
,251	39:01	,281	39:01	,311		,341	
,252	39:01	,282	39:01	,312		,342	
,253	39:01	,283	39:01	,313		,343	
,254	39:01	,284	40:01	,314		,344	
,255	71:01	,285		,315		,345	
,256		,286		,316		,346	
,257	70:01	,287	37:01	,317		,347	
,258	70:01	,288	37:01	,318		,348	
,259	71:01	,289		,319		,349	
,260	71:01	,290	41:01	,320		,350	
,261	17:01	,291	41:01	,321		,351	
,262	17:01	,292	41:01	,322		,352	
,263	57:01	,293	41:01	,323		,353	
,264		,294	41:01	,324		,354	
,265	35:01	,295		,325		,355	
,266	35:01	,296		,326		,356	
,267	34:01	,297		,327		,357	
,268	34:01	,298		,328		,358	
,269	35:01	,299		,329		,359	



TERMINAL SUMMARY "A"

Date: 93-03-17

Machine: 649205

ECN 19260 '0'  
19930317 HK

Position	Sheet	Position	Sheet	Position	Sheet	Position	Sheet	Position	Sheet
X001,360		X001,451	61:01	X001,481	64:01	X001,511	38:01		
,361		,452	64:01	,482	69:01	,512	38:01		
,362		,453	64:01	,483	69:01				
,363		,454	68:01	,484	69:01	M.X001,1	36:01		
,364		,455	68:01	,485	69:01	,2	36:01		
,365		,456	68:01	,486	62:01	,3	36:01		
,366		,457	68:01	,487	62:01	,4	36:01		
,367		,458	68:01	,488	70:01	,5	36:01		
,368		,459	68:01	,489	70:01	,6	36:01		
,369		,460	68:01	,490	70:01	,7	36:01		
,370		,461	68:01	,491	70:01	,8	36:01		
,371		,462	68:01	,492	68:01	,9	36:01		
,372		,463	68:01	,493	68:01	,10	36:01		
,373		,464	69:01	,494		,11	36:01		
,374		,465	69:01	,495		,12	36:01		
,375		,466	69:01	,496					
,376		,467	69:01	,497		F.X001,1	17:01		
,377		,468	69:01	,498		,2	17:01		
,378		,469	69:01	,499		,3	57:01		
,379		,470	61:01	,500		,4			
,380		,471	61:01	,501		,5	35:01		
,381		,472	64:01	,502	38:01	,6	35:01		
,382		,473	61:01	,503	38:01	,7	34:01		
,383		,474	61:01	,504	38:01	,8	34:01		
,384		,475	61:01	,505	38:01	,9	35:01		
,385		,476	61:01	,506	38:01	,10	35:01		
,386		,477	61:01	,507	38:01	,11	57:01		
,448	62:01	,478	61:01	,508	38:01	,12	57:01		
,449	62:01	,479	64:01	,509	38:01	,13			
,450	62:01	,480	64:01	,510	38:01	,14			

Based on ECN: 19260

TERMINAL SUMMARY 4- 44093-91:01

Sheet: 4  
Cont: 5



TERMINAL SUMMARY "A"

Date: 93-03-17

Machine: 649205

EDN 19260 '0'  
19930317 HK

Position	Sheet	Position	Sheet	Position	Sheet	Position	Sheet	Position	Sheet
M.X002,1	13:01	X003,0	05:01	M.X006,14	41:01	M.X006,44	41:01	M.X006,44	41:01
,2	13:01	,1	06:01	,15	35:01	,45	35:01	,45	35:01
,3	13:01	,3	14:01	,16	35:01	,46	35:01	,46	35:01
,4	37:01	,5	07:01	,17	35:01	,47	35:01	,47	35:01
,5	37:01	,8	07:01	,18	35:01	,48	35:01	,48	35:01
,6	45:01	,10	05:01	,19	45:01	,49	45:01	,49	45:01
,7	45:01	,17	11:01	,20	45:01	,50	45:01	,50	45:01
,8	45:01	,19	16:01	,21	45:01	,51	45:01	,51	45:01
,9	30:01	,90	30:01	,22	45:01	,52	45:01	,52	45:01
,10	30:01	,201	30:01	,23	45:01	,53	45:01	,53	45:01
,11	30:01	,202	07:01	,24	45:01	,54	45:01	,54	45:01
,12	30:01	,203	30:01	,25	40:01	,55	40:01	,55	40:01
,13	30:01	,204	30:01	,26	40:01	,56	40:01	,56	40:01
,14	30:01		30:01	,27	40:01	,57	40:01	,57	40:01
,15	30:01	M.X004,1	21:01	,28	40:01	,58	40:01	,58	40:01
,16	30:01	,2	21:01	,29	40:01	,59	40:01	,59	40:01
,17	30:01		30:01	,30	40:01	,60	40:01	,60	40:01
,18	30:01	M.X006,1	41:01	,31	40:01	,61	40:01	,61	40:01
,19	30:01	,2	41:01	,32	40:01	,62	40:01	,62	40:01
,20	30:01	,3	41:01	,33	40:01	,63	40:01	,63	40:01
,21	30:01	,4	41:01	,34	40:01	,64	40:01	,64	40:01
,22	30:01	,5	37:01	,35	40:01	,65	40:01	,65	40:01
,23	30:01	,6	37:01	,36	40:01	,66	40:01	,66	40:01
,24	24:01	,7	37:01	,37	40:01	,67	40:01	,67	40:01
,25	24:01	,8	37:01	,38	45:01	,68	45:01	,68	45:01
		,9	37:01	,39	45:01	,69	45:01	,69	45:01
F.X002,15	17:01	,10	37:01	,40	45:01	,70	45:01	,70	45:01
,16	17:01	,11	41:01	,41	45:01	,71	45:01	,71	45:01
,17	57:01	,12	41:01	,42	45:01	,72	45:01	,72	45:01
,18		,13	41:01	,43	45:01	,73	45:01	,73	45:01

Based on EDN: 19260

TERMINAL SUMMARY

4- 44093-91:01

Sheet: 5  
Cont: 6



TERMINAL SUMMARY "A"

Date: 93-03-17

Machine: 649205

ECN 19260 '0'  
19930317 HK

Position	Sheet	Position	Sheet	Position	Sheet	Position	Sheet	Position	Sheet
M.X006,74		M.X007,28	41:01	M.X014,3	10:01	X019,3	10:01	X019,3	06:01
,75		,29	41:01	,4	39:01	,5	39:01	,5	06:01
		,30	41:01	,5	39:01	,7	39:01	,7	06:01
M.X007,1	37:01	,31	41:01	,6	39:01		39:01		06:01
,2	37:01	,32		,7	39:01	X021,1	39:01	X021,1	06:01
,3	37:01	,33		,8	39:01	,2	39:01	,2	06:01
,4	37:01	,34		,9	39:01	,3	39:01	,3	06:01
,5	37:01	,35		,10	39:01	,4	39:01	,4	06:01
,6	37:01	,36		,11	71:01	,5	71:01	,5	06:01
,7	37:01	,37		,12	71:01	,6	71:01	,6	06:01
,8									
,9		M.X008,1	07:01	X016,1	31:01	X023,1	31:01	X023,1	06:01
,10		,2	07:01	,2	31:01	,2	31:01	,2	06:01
,11		,3	07:01	,3	31:01	,3	31:01	,3	06:01
,12	69:01	,4	07:01	,4	31:01	,4	31:01	,4	06:01
,13	69:01			,5	31:01		31:01		06:01
,14	71:01	X009,1	32:01	,6	31:01	X024,1	31:01	X024,1	06:01
,15	71:01	,2	32:01	,7	31:01	,2	31:01	,2	06:01
,16	39:01	,3	32:01	,8	31:01		31:01		06:01
,17	39:01	,4	32:01	,9	31:01	M.X0326,1:1	31:01	M.X0326,1:1	62:01
,18	39:01	,5		,10	31:01	,1:2	31:01	,1:2	62:01
,19		,6		,11	31:01	,2:1	31:01	,2:1	62:01
,20		,7		,12	31:01	,2:2	31:01	,2:2	62:01
,21		,8		,13	31:01	,3:1	31:01	,3:1	61:01
,22				,14	31:01	,3:2	31:01	,3:2	61:01
,23		X011,3	16:01	,15	31:01	,4:1	31:01	,4:1	64:01
,24		,47	05:01			,4:2		,4:2	64:01
,25				X017,1	06:01		06:01		64:01
,26		M.X014,1	10:01	,2	06:01	,5:1	06:01	,5:1	64:01
,27		,2	10:01	,3	06:01	,5:2	06:01	,5:2	64:01

Based on ECN: 19260

TERMINAL SUMMARY

4- 44093-91:01

Sheet: 6  
Cont: 7



TERMINAL SUMMARY "A"

Date: 93-03-17

Machine: 649205

ECN 19260 'D'  
19930317 HK

Position	Sheet	Position	Sheet	Position	Sheet	Position	Sheet
M.X032B,1:1	68:01	M.X034A,1:2	61:01	M.X038,1	18:01	X100,4	14:01
,1:2	68:01	,2:1	64:01	,2	18:01	,5	14:01
,2:1	68:01	,2:2	64:01			,6	14:01
,2:2	68:01	,3:1	61:01	M.X039,1	19:01	,7	14:01
,3:1	68:01	,3:2	61:01	,2	19:01	,8	14:01
,3:2	68:01	,4:1	61:01			,9	14:01
,4:1	68:01	,4:2	61:01	M.X040,1	18:01	,10	14:01
,4:2	68:01	,5:1	61:01	,2	18:01	,11	14:01
,5:1	68:01	,5:2	61:01			,12	14:01
,5:2	68:01			M.X050,1	20:01	,13	14:01
		M.X034B,1:1	61:01	,2	20:01	,14	14:01
		,1:2	61:01			,15	14:01
M.X033A,1:1	68:01	,2:1	61:01	M.X055,1	20:01	,16	14:01
,1:2	68:01	,2:2	61:01	,2	20:01	,17	14:01
,2:1	68:01	,3:1	64:01			,18	14:01
,2:2	68:01	,3:2	64:01	X071,1	14:01	,19	14:01
,3:1	68:01	,4:1	64:01			,20	14:01
,3:2	68:01	,4:2	64:01	M.X071,1	14:01	,21	14:01
,4:1	69:01	,5:1	64:01			,22	14:01
,4:2	69:01	,5:2	64:01	X072,1	14:01	,23	14:01
,5:1	69:01					,24	14:01
,5:2	69:01	M.X036,1	21:01	M.X072,1	14:01	,25	14:01
		,2	21:01			,26	14:01
M.X033B,1:1	69:01			M.X073,1	14:01	,27	14:01
,1:2	69:01					,28	14:01
,2:1	69:01	M.X037A,1	19:01			,29	14:01
,2:2	69:01	,2	19:01	M.X074,1	14:01	,30	14:01
,3:1	69:01						
,3:2	69:01	M.X037B,1	19:01	X100,1	14:01		
		,2	19:01	,2	14:01	M.X109,1	39:01
				,3	14:01	,2	39:01
M.X034A,1:1	61:01						

Based on ECN: 19260

TERMINAL SUMMARY 4- 44093-91:01

Sheet: 7  
Cont: 6



TERMINAL SUMMARY "A"

Date: 93-03-17

Machine: 649205

ECN 19260 '0'  
19930317 HK

Position	Sheet	Position	Sheet	Position	Sheet
M.X109,3	39:01				
,4	39:01				
,5	39:01				
,6	39:01				
,7	39:01				
,8	39:01				
,9	39:01				
,10	40:01				
,11	40:01				
,12	40:01				
,13					
,14					
,15					
,16					
,17					
,18					
,19	37:01				
,20	37:01				

Based on ECN: 19260

TERMINAL SUMMARY

4- 44093-91:01

Sheet: 8  
Cont: ..



AM-NO    DRAWING-NO.    ALTERATIONS

CIRCUIT DIAGRAM  
44093-07:01

44093-10:01    CONNECTION BETWEEN T009 AND X001:55  
44093-11:01    CHANGED FROM 0 TO 10  
44093-12:01    CONNECTION REFERENCE "A" IS INTRODUCED  
44093-14:01    CONN. REF. "C" AND "D" ARE INTRODUCED,  
44093-16:01    TEXT "PRELIMINAR" IS REMOVED.  
44093-17:01    CONN. REF. "B" IS INTRODUCED,  
44093-18:01    0099 TEXT SH.32 IS CHANGED TO SH.41.  
44093-19:01    M001 PINS ARE NOW SHOWN.  
44093-20:01    CABLE V.UP AND V.DOWN ARE REMOVED.  
44093-21:01    F019 PINS HAVE INVERTED THEIR PLACE,  
44093-22:01    F055(B-C) HAVE CHANGED THEIR PIN NUMBERS,  
44093-23:01    L50 CONNECTION POINT INTRODUCED.  
44093-24:01    D108:1 IS INTRODUCED  
44093-25:01    X001:113 IS CHANGED FROM A116:01 TO A117:02  
44093-26:01    K036 SHEET REFERENCE IS CHANGED TO 63-63-62  
44093-27:01    TEXT A115:15 IS CHANGED TO A115:13.  
44093-28:01    M.X007:3 AND 2 HAVE INVERTED THEIR PLACE.  
44093-29:01    M.B002 SYMBOL IS CHANGED FROM NO. TO NC.  
44093-30:01    M.B104: TEXT "B. VALVE" IS REMOVED.  
44093-31:01    X001:168, M.X006:19 AND :20 ARE INTRODUCED,  
44093-32:01    CONNECTION BETWEEN M.X006:27 AND :32  
44093-33:01    IS INTRODUCED  
44093-34:01    K075 SHEET REFERENCE IS CHANGED TO SH.65.  
44093-35:01    TEXT P.L1:06 "SHORT STOP" IS CHANGED TO  
44093-36:01    "NO PRODUCTION ALLOWED".  
44093-37:01    TEXT K087 IS CORRECTED TO ADDING "INLET".  
44093-38:01    M.Y012 HAS INVERTED PLACE WHIT M.Y014.  
44093-39:01    M.Y019 HAS CHANGED PLACE TO M.X032B 1:1 1:2  
44093-40:01    A121:13 TEXT IS CHANGED FROM SH.33 TO 32.

AM-NO    DRAWING-NO.    ALTERATIONS

44093-90:01    LINE SUMMARY:  
44093-99:01    L51 X.L51.1: K048,13 AND F019,1 ARE ADDED,  
F019,2 IS REMOVED.  
L51 X.L51.2: K048,13 IS REMOVED.  
ALTERATION MESSAGES IS UPDATE:  
PAG.1 IS CHANGED, PAG.2 IS ADDED.

TPMC-PROGRAM  
47615-01:01    LIST OF BLOCKS IS ADDED.  
47615-02:01    LIST OF ADDRESSES IS ADDED  
47615-03:01    VOLUME ADAPTION DOCUMENT IS ADDED.  
47615-04:01    SEQUENCE DIAGRAM IS ADDED.  
47615-05:01    PROGRAM LIST IS ADDED.  
47615-06:01    PROGRAM LIST IS ADDED  
47615-07:01    PROGRAM LIST IS ADDED  
47615-08:01    PROGRAM LIST IS ADDED  
47615-09:01    PROGRAM LIST IS ADDED  
47615-10:01    PROGRAM LIST IS ADDED  
47615-11:01    PROGRAM LIST IS ADDED  
47615-12:01    PROGRAM LIST IS ADDED  
47615-13:01    PROGRAM LIST IS ADDED  
47615-14:01    PROGRAM LIST IS ADDED  
47615-17:01    PROGRAM LIST IS ADDED  
47615-18:01    PROGRAM LIST IS ADDED  
47615-19:01    PROGRAM LIST IS ADDED  
47615-20:01    PROGRAM LIST IS ADDED  
47615-23:01    PROGRAM LIST IS ADDED  
47615-24:01    PROGRAM LIST IS ADDED  
47615-25:01    PROGRAM LIST IS ADDED  
47615-26:01    PROGRAM LIST IS ADDED  
47615-27:01    PROGRAM LIST IS ADDED  
47615-28:01    PROGRAM LIST IS ADDED  
47615-29:01    PROGRAM LIST IS ADDED  
47615-30:01    PROGRAM LIST IS ADDED  
47615-31:01    PROGRAM LIST IS ADDED  
47615-32:01    PROGRAM LIST IS ADDED  
47615-33:01    PROGRAM LIST IS ADDED  
47615-90:01    PROGRAM LIST IS ADDED  
47615-99:01    PROGRAM LIST IS ADDED

ISSUE	A	B	C	D	E	F	G	H	HK/ZUTH	DATE	930310	STDA.	DESCRIPTION:
20080										20720	20513	20555	ALTERATION MESSAGES
930909										15193101519311129	940427	940916	TBA/9-1401 S.A
													MACHINE: 44093-99:01 2/3

AM-NO    DRAWING-NO.

MOUNTING DRAWING  
52471-08:01

52471-15:01  
52471-25:01

CONNECTION DIAGRAM

61232-06:01  
61232-13:01

61232-16:01

61232-22:01

61232-28:01

61232-43:01

61232-45:01

61232-48:01

TERMINAL DRAWINGS  
570926-0004

571519

571520

571524

571525

571517

ALTERATIONS

FUSES ARE CHANGED; F1,5,8,17,19, NOW ARE PLACED IN THIS ORDER FROM LEFT TO RIGHT; F1,8,5,S,19,S,17,....  
M.B104 AND M.B108 ARE INTRODUCED.  
DISTANCE BETWEEN 1-2-3-4 ARE CHANGED; SEE "DRAWING REMARKS".

CABLE 307 CHANGED FROM 1-2-3 TO BU-BK-BN.  
CABLE OF EMERGENCY STOP IS CHANGED FROM 5-6 TO 3-4.  
M.B021A-C CABLE TEXT ARE CHANGED FROM BK-BK TO BK-BU.  
M.B010 SYMBOL IS CHANGED: NO CONNECTED TO BK, NC CONNECTED TO BN.  
IN THE CABLE 26 THE Y/G. WIRE IS DELETED.  
M.B108B CABLE TEXT CHANGED FROM BU-BK TO BK-BK.  
M.Y019 CHANGED FROM M.X032B 5:1 AND 5:2 TO M.X032B 1:1 AND 1:2.  
M.Y012 AND 14 HAVE INVERTED THEIR PLACE.  
M.B002 SYMBOL IS CHANGED.

POS. 0313 IS ADDED  
DISTANCE BETWEEN :2 AND THE EDGE IS CHANGED TO 80 MM.  
POS. :9 IS REMOVED.  
POS. :7 IS CHANGED FROM 10 PCS TO 7 PCS.  
POS. :15 IS INTRODUCED.  
POS. :1 IS CHANGED FROM 110MM. TO 120MM.  
P.X002 IS MOVED CLOSER TO THE EDGE.  
POS. :2 IS CHANGED FROM 8 PCS TO 6 PCS.  
POS. :3 IS REMOVED.  
POS. :6 IS ADDED

FUSES PANEL LABEL:  
F1,5,8,17,19, NOW ARE  
PLACED IN THIS ORDER FROM LEFT TO RIGHT;  
F1,8,5,S,19,S,17,....

AM-NO    DRAWING-NO.

20398

CE-41723-010V

CE-41727-010V

CIRCUIT DIAGRAM

44093-07:01

44093-99:01

TPMC PROGRAMME

47615-07:01

47615-31:01

571517

20406

CE-41723-010V

CE-41727-010V

CIRCUIT DIAGRAM

44093-38:01

44093-99:01

ALTERATIONS

CTRL. CAB. IS CHANGED;  
POS. 0077; PART NUMBER IS CHANGED FROM 90259-0026 TO 90259-0027.

EXTRA EQU. IS CHANGED;  
POS. 0077 IS ADDED.

THE NOTE 1 MOVED FROM M.R038 TO M.R037.  
THE M.R038 CONNECTION HAS BEEN CHANGED.  
ALTERATION MESSAGE IS UPDATE

RUNG 0714;

THE PARALLEL BRANCH WHIT D055 MOVED IN THE FIRST PARALLEL POSITION DUE TO THE FUNCTION OF DON; T0000.1 MOVED BEFORE D055.

RUNG 3104;

T0000.1 MOVED BEFORE D067.

FUSE PANEL LABEL;

0077 CHANGES THESE TWO VALUES;  
50HZ. FROM 9,7A. TO 10A.  
60HZ. FROM 8,0A. TO 9A.

CTRL. CAB. LIST IS CHANGED;

POS.320-330 DELETED; POS.045 INTRODUCED.

EXTRA EQUIPMENT IS CHANGED;

0077 CHANGE PART NUMBER FROM 90259-0027 TO 90259-0026.

THE VARIANT DESCRIPTION TEXTS ARE CHANGED

THE CONNECTION FOR M.B006 HAS BEEN CHANGED FROM 1 AND 3 TO 13 AND 14.

NOTE 1 IS INTRODUCED

ALTERATION MESSAGE IS UPDATE;

PAG.3 IS CHANGED, PAG.4 IS ADDED.

INTRODUCED WITH AM NO.		DATE:	STDA:	HK/UTHT
A	B	C	D	E
20080	20398	20406	20698	20720
93090931001931015931119311129940427940916951010	HK/MR/IKK/MR/IKK/MR/IKK/MR/IKK/MR/IKK/PRJ	HK/MR/IKK/MR/IKK/MR/IKK/MR/IKK/PRJ	HK/MR/IKK/MR/IKK/MR/IKK/PRJ	HK/MR/IKK/MR/IKK/MR/IKK/PRJ
ISSUE	AM NO.	DATE	STDA	DESCRIPTION
20080	20398	20406	20698	20720
93090931001931015931119311129940427940916951010	HK/MR/IKK/MR/IKK/MR/IKK/MR/IKK/PRJ	HK/MR/IKK/MR/IKK/MR/IKK/PRJ	HK/MR/IKK/MR/IKK/MR/IKK/PRJ	ALTERATION MESSAGES
MACHINE:				TBA/9-1401 S.A
ALTERATIONS ONLY IN CADAM				44093-99:01 3/4

<u>AM-NO</u>	<u>DRAWING-NO.</u>	<u>ALTERATIONS</u>	<u>AM-NO</u>	<u>DRAWING-NO.</u>	<u>ALTERATIONS</u>
20513	CE-41726-010V	VOLUME ADAPTION DOCUMENT IS CHANGED: RUNG 621 IS CORRECTED TO 624, AND ITS REF. INSTRUCTION CHANGE FROM 017.10 TO M06.00 RUNG 1434 VALUE 200 S. CHANGE FROM KFE9FH TO KFF9FH			EQUIPMENT IS CHANGED: TPMC PROGRAMME DISK IS UPDATE TO THIS ECN. EXTRA EQUIPMENT IS CHANGED: POS. 0077 IS REMOVED. SPARE PART KIT IS CHANGED: POS. 0110 IS REMOVED. ALTERATION MESSAGE IS UPDATE
	CE-41727-010V				
	CE-41728-010V				
	CIRCUIT DIAGRAM 44093-99:01	THE M.R038 PIN CONFIGURATION IS DELETED THE CONNECTION FOR M.B006 HAS BEEN CHANGED FROM 1 AND 3 TO 13 AND 14. NOTE 1 IS INTRODUCED			LIST OF ADDRESSES IS CHANGED: SOME TEXT CORRECTIONS VOLUME ADAPTION DOCUMENT IS CHANGED: RUNG 624 IS CORRECTED TO 621 VALUES FOR RUNGS 1406, 1408 VALID FOR ALL VOLUMES, BESIDE 250 SLIM, ARE ADDED. VALUES FOR RUNGS 1434, 1435, VALID FOR 284 VOLUME, ARE ADDED. ISSUE OF ECN 20698 IS CORRECTED FROM A TO B VOLUME COLUMN 180 CC CHANGED TO 160 CC AND ADD NEW VALUES. TEXT CORRECTIONS TEXT CORRECTIONS TEXT CORRECTIONS TEXT CORRECTIONS TEXT CORRECTIONS TEXT CORRECTIONS TEXT CORRECTIONS TEXT CORRECTIONS TEXT CORRECTIONS TEXT CORRECTIONS RUNG 2704:VALUE OF D005 CHANGE FROM 5 TO 10 TEXT CORRECTIONS TEXT CORRECTIONS TEXT CORRECTIONS
	TPMC PROGRAMME 47615-02:01				
	47615-03:01				
20698	CIRCUIT DIAGRAM 44093-99:01	ALTERATION MESSAGE IS UPDATE			
	TPMC PROGRAMME 47615-02:01	LIST OF ADDRESSES IS CHANGED VOLUME ADAPTION DOCUMENT IS CHANGED: A NEW VOLUME 250CC SLIM IS ADDED. THE RUNGS 1406-1408 ARE ADDED WITH THIS NEW VOLUME.			
	47615-03:01				
	47615-14:01	RUNG 1406 AND 1408: VOLUME DEPENDENT TEXT ARE INTRODUCED.			
	47615-17:01	RUNG 1705; D024 IS INTRODUCED RUNG 1706: BRANCH WITH M00.05 AND D024 ARE REMOVED			
	47615-18:01	RUNG 1811; M00.07 IS REMOVED			
20720	CE-41725-010V	MACHINE IS CHANGED: POS. 0372-0373: PART N.548770-005 ARE CHANGED IN 548770-0008			
	CIRCUIT DIAGRAM 44093-99:01	ALTERATION MESSAGE IS UPDATE			

FUSE PANEL LABEL:  
POS.0077, 60HZ.: CHANGE FROM 9A. TO 10A.

INTRODUCED WITH AM NO.	DATE.	BY.	CHK/UTH	DESCRIPTION.
19260	930310	F	G	ALTERATION MESSAGES
20080	20398	C	H	
20406	20698	D		
20720	20513	E		
930909	931001	F		
931015	931129	G		
931193	940427	H		
940916	951010	I		
HK/MRI/HK/MRI/HK/MRI/HK/MRI/HK/PRI				MACHINE: TBA/9-1401 S.A 44093-99:01 4/5

AM-NO     DRAWING-NO.     ALTERATIONS

AM-NO     DRAWING-NO.     ALTERATIONS

<p>20555     4-571516 CE-41724-010V.  CIRCUIT DIAGRAM 44093-99:01  TPMC PROGRAMME 47615-02:01 47615-04:01  47615-26:01</p>	<p>INDEX: NEW FRAME IS INTRODUCED. CONTROL PANEL LIST IS CHANGED; POS. W017 CHANGED FROM 351150-407 TO 351150-408.  ALTERATION MESSAGE IS UPDATED; PAG.5 IS ADDED.  LIST OF ADDRESSES IS CHANGED MACH. OPERATION DIAGRAM, TEXT CORRECTIONS: 'SIGNAL TO CIP' TO 'SIGNAL TO STERILE' 'SIGNAL TO STERILE' TO 'SIGNAL FROM STER.' RUNG 2602; T0015.1 REPLACED BY 017.03. RUNG 2603; -NEW OUTPUT BRANCH 017.04. -I03.11 CONTACT REPLACED BY NON-CONTACT. -T0016.1 REPLACED BY 017.04 RUNG 2604; T0016.1 REPLACED BY 017.04</p>	<p>AM-NO     DRAWING-NO.     ALTERATIONS</p>
<p>22852     CE-41724-010V  CIRCUIT DIAGRAM 44093-99:01  TPMC PROGRAM 47615-02:01  47615-12:01</p>	<p>CONTROL PANEL LIST IS CHANGED; POS. W017 CHANGED FROM 351150-408 TO 351150-407.  ALTERATION MESSAGES IS UPDATED.  LIST OF ADDRESSES IS UPDATED WITH THE NEW ALTERATION ON THE PROGRAM. TWO NEW RUNGS ARE INSERTED AFTER RUNG 1208 IN RENUMBERED RUNG 1211 THE SECOND BRANCH IS ADDED. IN RENUMBERED RUNG 1214 A BRANCH IS ADDED.</p>	<p>AM-NO     DRAWING-NO.     ALTERATIONS</p>

ISSUE	A	B	C	D	E	F	G	H	
AM NO.	20080	20398	20406	20698	20720	20513	20555	22852	
DATE	930909	931001	931015	931119	931129	940427	940916	951010	
SIGN.	HK/MRI	HK/MRI	HK/MRI	HK/MRI	HK/MRI	HK/MRI	HK/PRI	HK/PRI	
INTRODUCED WITH AM NO.	19260	930310							
DATE	C	D	E	F	G	H	HK/ZUTH		
DESCRIPTION:	ALTERATION MESSAGES								
MACHINE:	TBA/9-1401 S.A							44093-99:01	5/-

This drawing must not, without the consent of Tetra Pak, be copied, transmitted or disclosed to any third party.

COMPRESSION GLAND  
352103-122

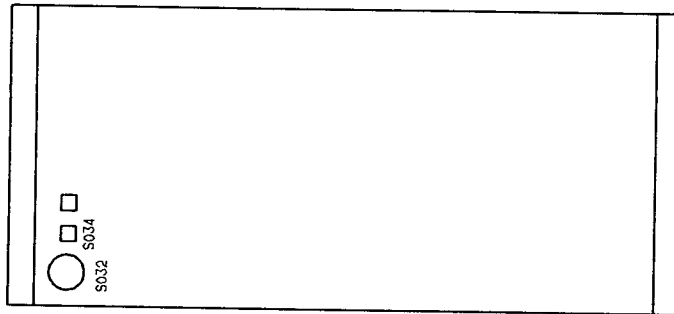

RIGHT HAND VIEW

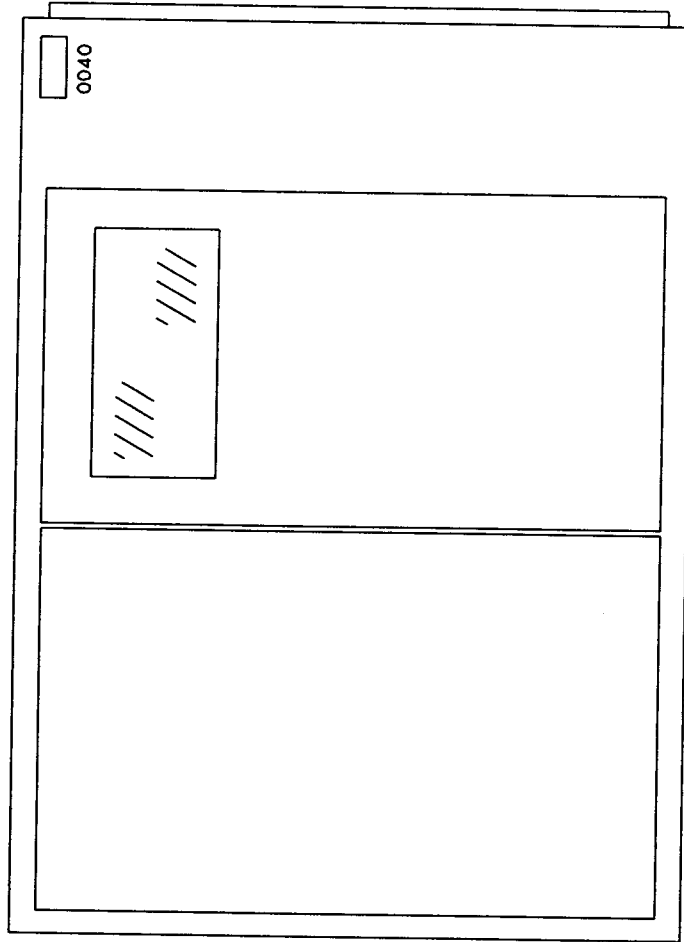

FRONT VIEW

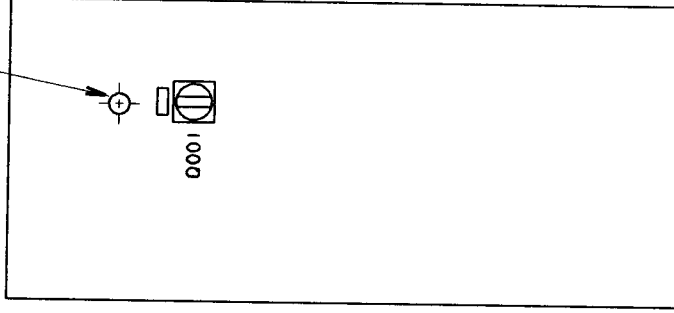

LEFT HAND VIEW

INTRODUCED WITH AM. NO.	19260	DATE	930310	BY	HK/JUTH
TABLE					
AM. NO.					
DATE					
BY					
ALTERATIONS ONLY IN CADAM					
DESCRIPTION:				MOUNTING DRAWING	
MACHINE:				TBA/9-1401 S.A	
				52471-05:01	

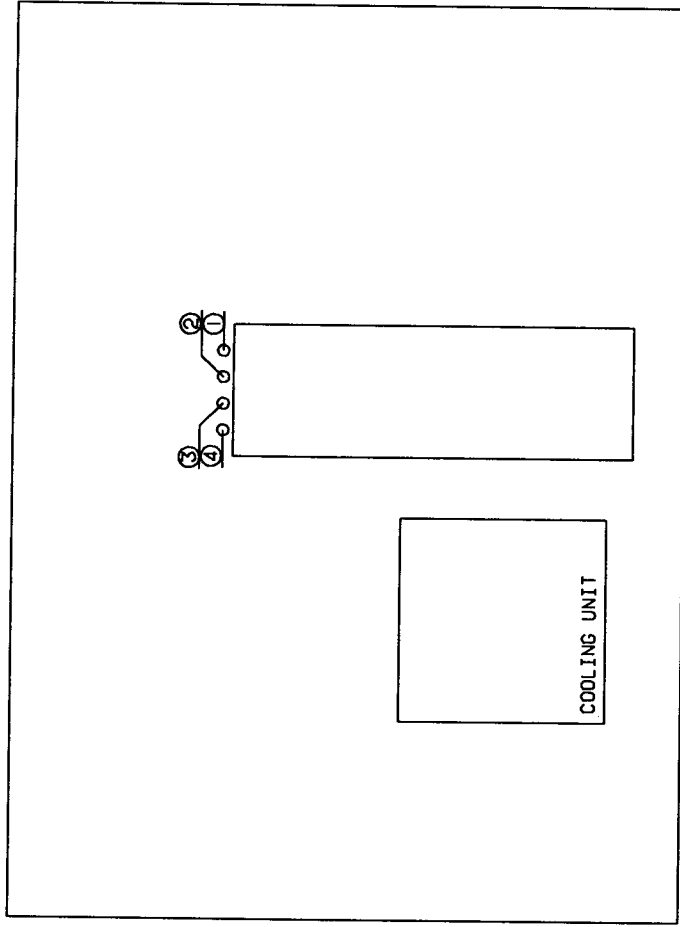

REAR VIEW

INTRODUCED BY: AM NO.	19260	DATE:	930310	BY:	HK/UTH	DESCRIPTION:	MOUNTING DRAWING	
TABLE								
AM NO.								
DATE								
BY:								
DRAWING REMARKS							MACHINE:	TBA/9-1401 S.A
ALTERATIONS ONLY IN CADAM								52471-06:01

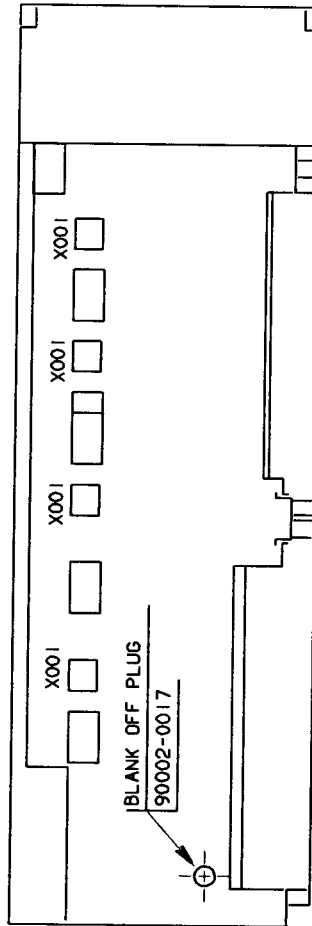
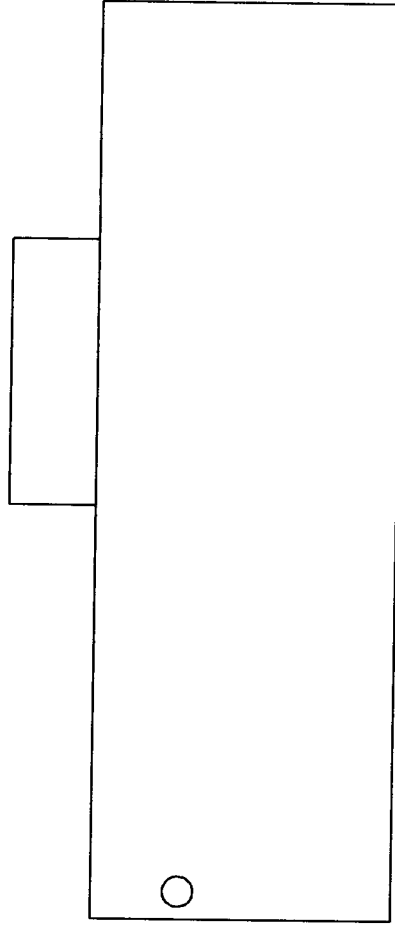
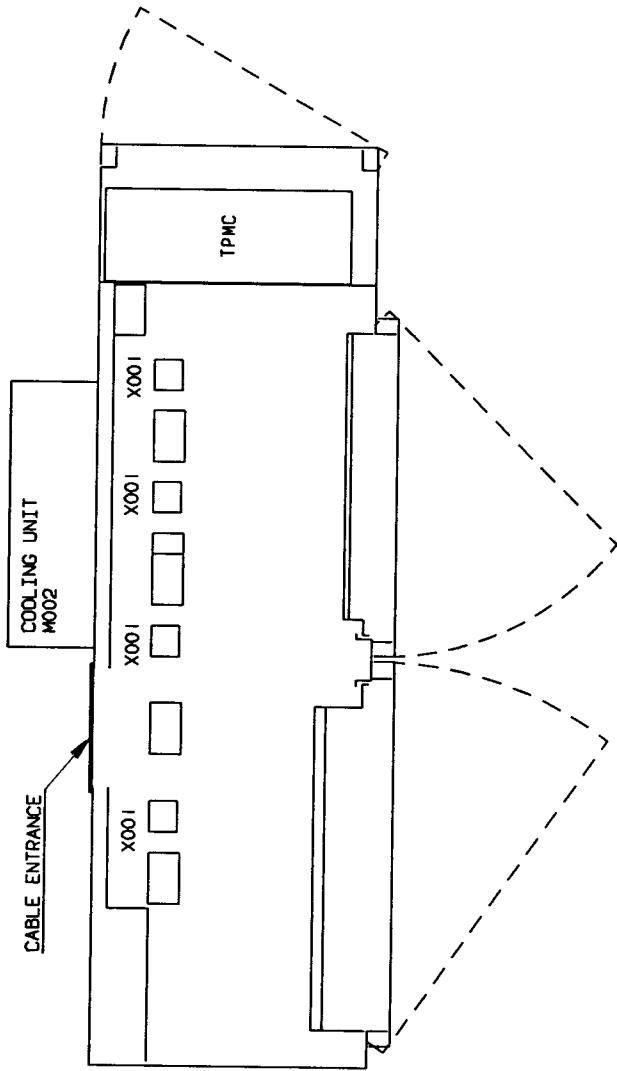

FLOOR VIEW

TOP VIEW

INTRODUCED WITH AM NO.	19260	DATE	930310	BY	HK/UTH
TITLE					
AM NO.					
DATE					
BY					
ALTERATIONS ONLY IN CADAM					
DESCRIPTION:			MOUNTING DRAWING		
MACHINE:			TBA/9-1401 S.A		
			52471-07:01		

DRAWING REMARKS





This drawing must not, without the consent of Tetra Pak, be copied, transmitted or disclosed to any third party.

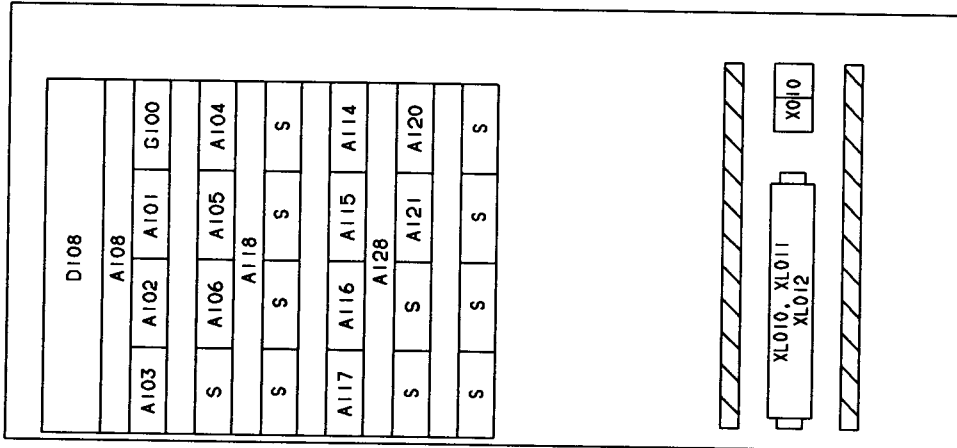
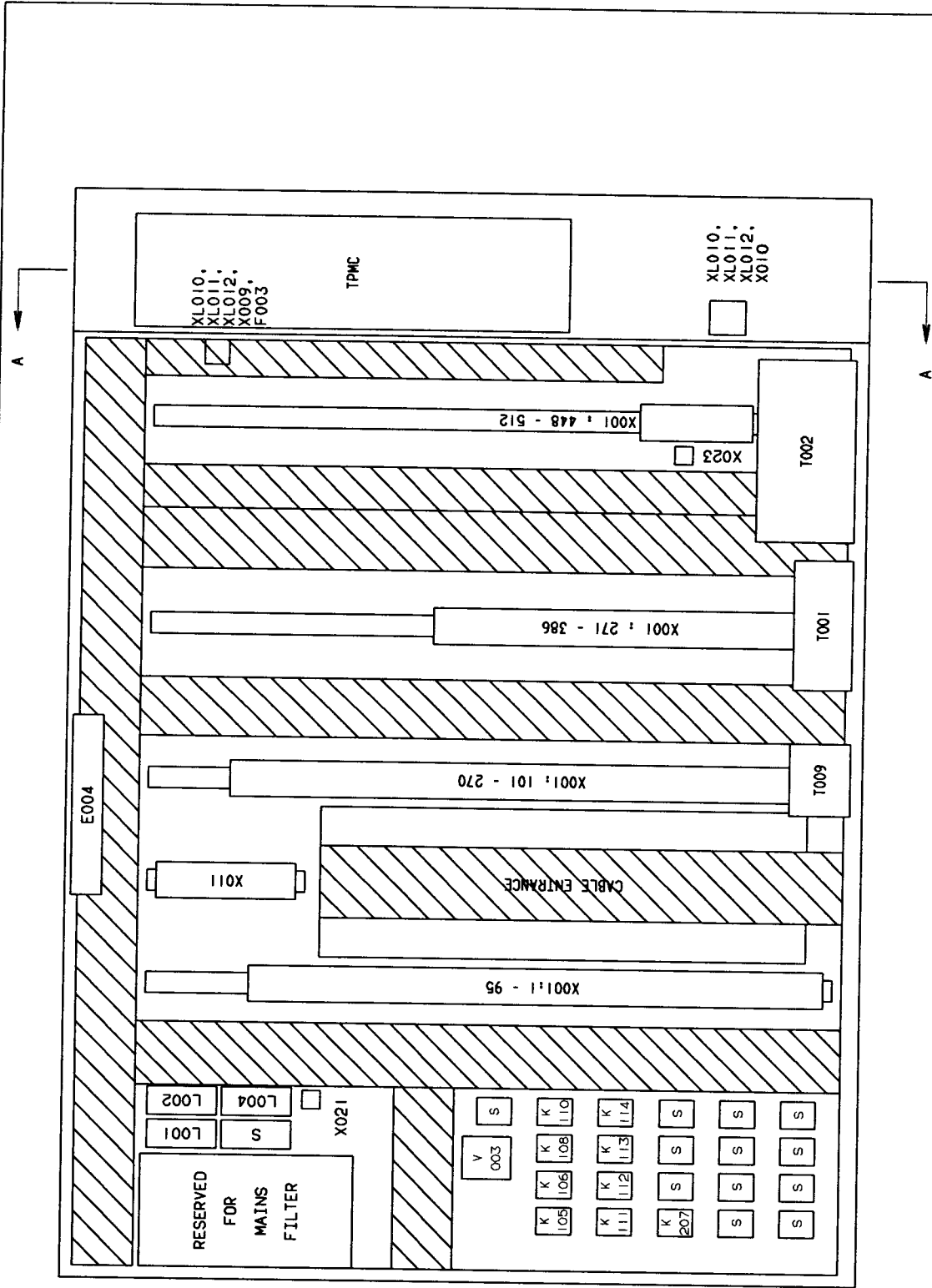

VIEW A-A

HYDROULIC AM. NO.	19260	DATE	930310	BRN.	HK/LUTH
TABLE					
AM. NO.					
DATE					
BRN.					
ALTERATIONS ONLY IN CADAM					
DESCRIPTION:			MOUNTING DRAWING		
MACHINE:			TBA/9-1401 S.A		
			52471-10:01		
DRAWING REMARKS					

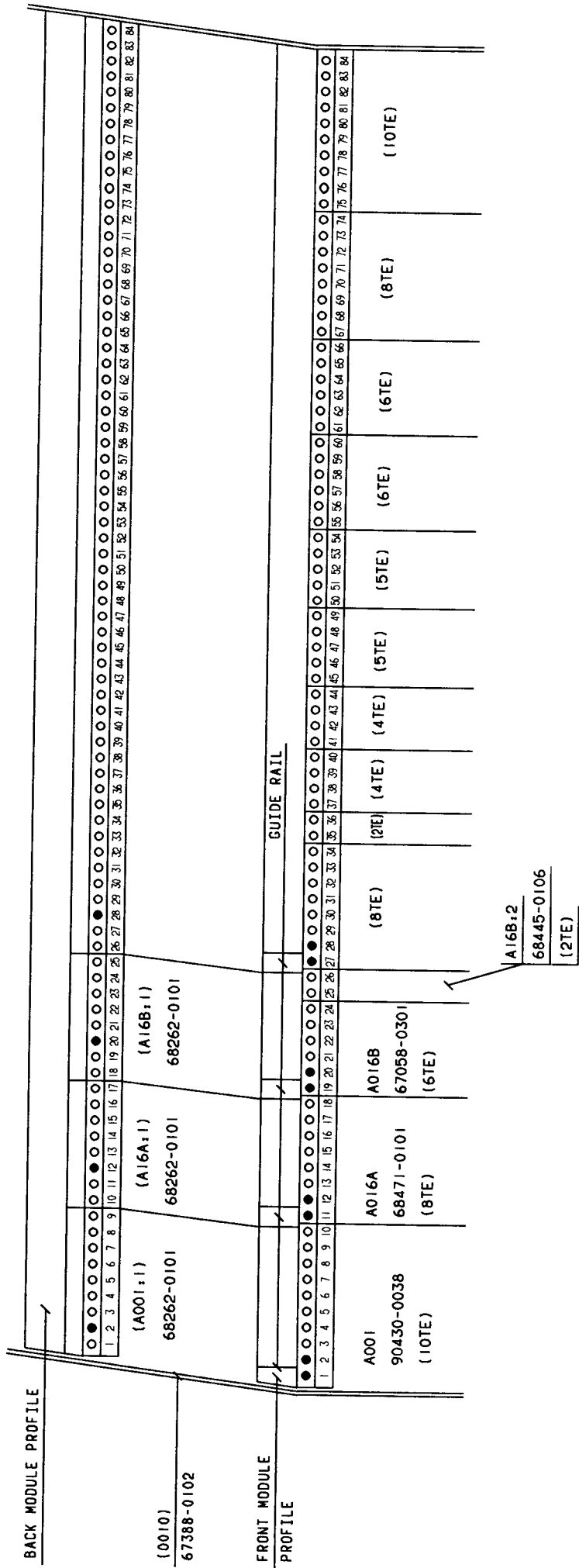

INTRODUCED WITH AM NO.	19260	DATE	930310	BY	HK/LJTH
TABLE AM NO.					
DATE					
BY					
ALTERATIONS ONLY IN CADAM					
DESCRIPTION: MOUNTING DRAWING, RACK 0010				MACHINE: TBA/9-1401 S.A	
				52471-11:01	

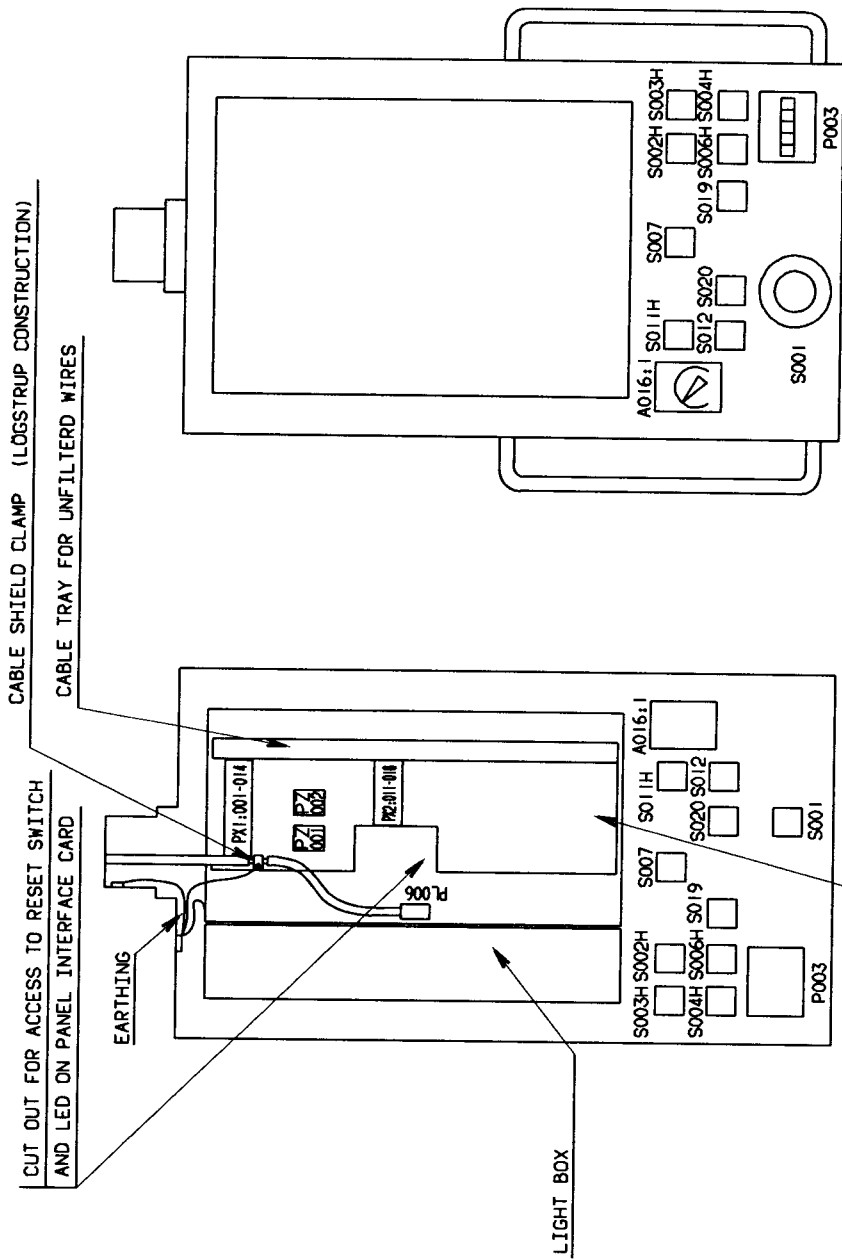

FRONT VIEW

MOUNTING PLATE FOR FILTERS,  
TERMINALS AND CABLE TRAY.  
MOUNTED ABOVE PANEL INTERFACE CARD.

INTRODUCED BY: AM NO.	19260	DATE:	930310	SIGN.	HK/LUTH
TABLE					
REV. NO.					
DATE					
SIGN.					
ALTERATIONS ONLY IN CADAM					
DESCRIPTION:				MOUNTING DRAWING	
MACHINE:				TBA/9-1401 S.A	
				52471-12:01	

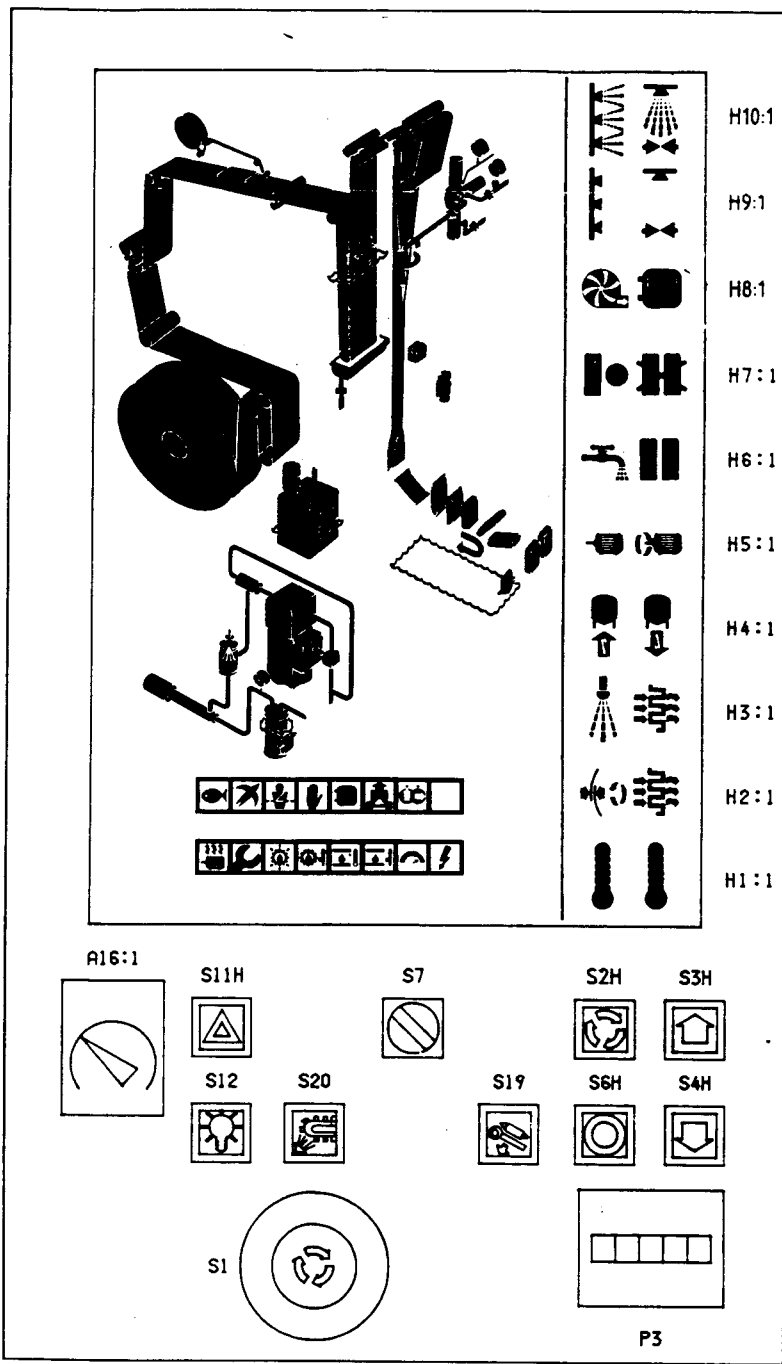

H1:1 PREHEATING I  
 H1:2 PREHEATING II  
 H2:1 TUBE SEALING  
 H2:2 PRESTERILIZING  
 H3:1 SPRAYING  
 H3:2 DRYING  
 H4:1 SIGNAL TO STERILIZER  
 H4:2 SIGNAL FROM STERILIZER  
 H5:1 START SEQUENCE  
 H5:2 DRIVE MOTOR  
 H6:1 FILLING  
 H6:2 PRODUCTION  
 H7:1 NO PRODUCTION ALLOWED  
 H7:2 PRODUCTION FINISHED  
 H8:1 WORK ENVIRONMENT ASEPTIC CHAMBER ON  
 H8:2 WEAC READY FOR DOOR OPENING  
 H9:1 PREPARE FOR CLEANING OF MACHINE  
 H9:2 PREPARE FOR CLEANING OF VALVE  
 H10:1 CLEANING OF MACHINE  
 H10:2 CLEANING OF VALVE

A16:1 DESIGN CORRECTION  
 P3 PACKAGE COUNTER, PRODUCTION  
 S1 EMERGENCY STOP  
 S2H INCHING  
 S3H STEP UP  
 S4H STEP DOWN  
 S6H SHORT STOP  
 S7 SELECTOR SWITCH  
 S11H ALARM RESET  
 S12 LAMP TEST  
 S19 DROP CHUTE OFF  
 S20 STATION CHAIN SPRINKLER  
 P3 PACKAGE COUNTER, PRODUCTION

Description: MOUNTING DRAWING, CONTROL PANEL

Machine: TBA / 9-1401 S.A. 52471-13:01

Drawing Remarks

Introduced with AM No. 19260 Date: 930310 Sign. HK/UTH

Issue AM No. Date Sign.

A B C D E G H K L M N O P R S T U V X Y Z

RA Heilich

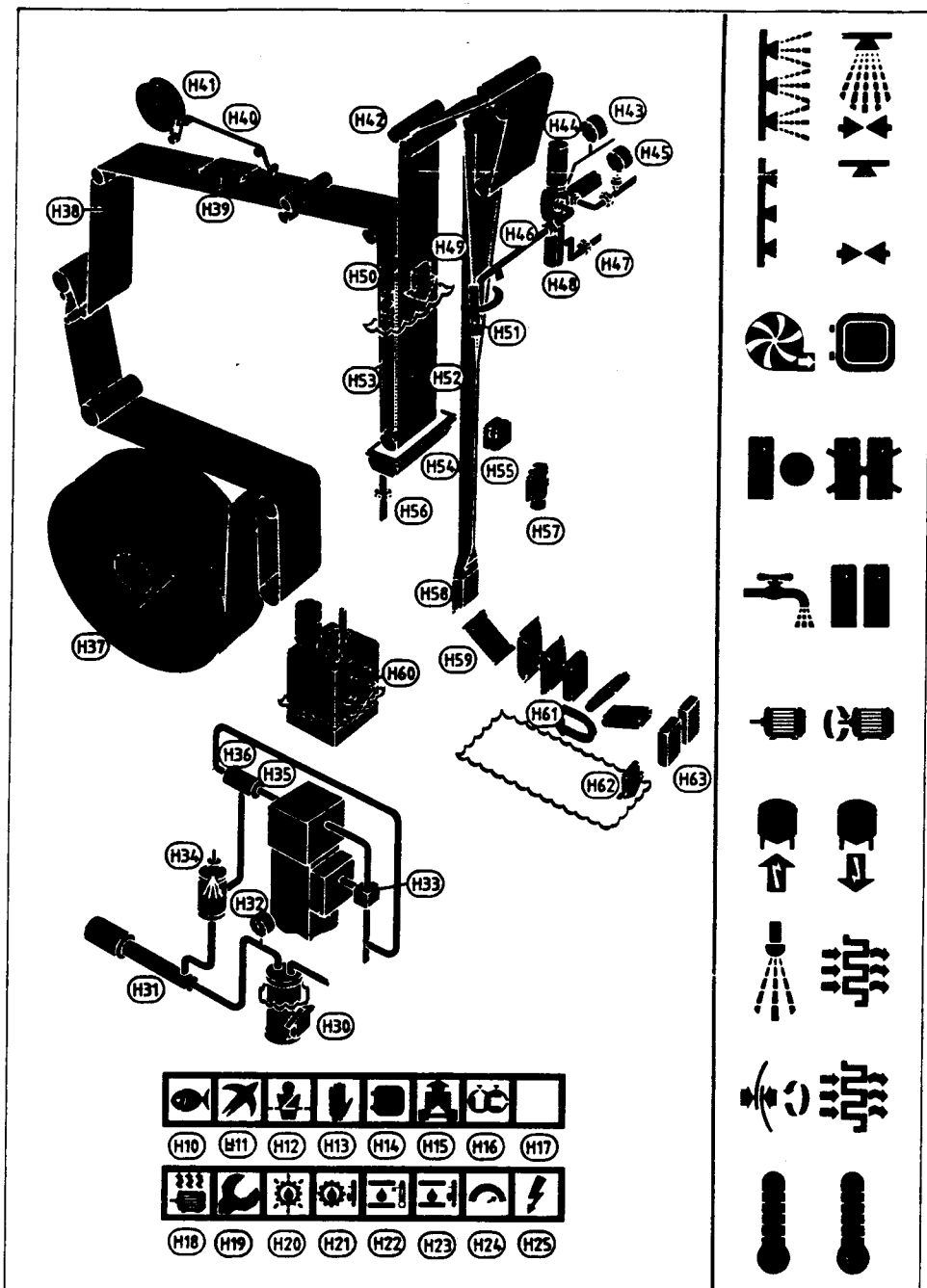

- |     |                                    |     |                                       |
|-----|------------------------------------|-----|---------------------------------------|
| H10 | TOO LOW PRESS. COOL. WATER         | H37 | SUPPLY OF PAPER TOO LOW               |
| H11 | TOO LOW PRESS. AIR                 | H38 | ROT. MONITOR PAPER WEB FAULT          |
| H12 | SAFETY MONITORS IN OFF POS.        | H39 | TOO LOW TEMP. AT STRIP APPLICATOR     |
| H13 | ACTIVATED EMERGENCY STOP           | H40 | STRIP APPLICATOR STRIP BROKEN         |
| H14 | MONIT. SUPERV. POS. OF TOWER DOORS | H41 | STRIP APPLICATOR SUPPLY TOO LOW       |
| H15 | OVERLOAD JAW SYSTEM                | H42 | INCORR. POS. SQUEEZ ROLL. AIR KNIFE   |
| H16 | UNSYNCHR. BETWEEN MM/FF            | H43 | STEAM TEMP. OUT OF LIMITS             |
| H17 | RESERV                             | H44 | CLEANING STEAM BARRIER SPACE          |
| H18 | TRIPPED OVERLOAD PROT. OF MOTORS   | H45 | NO PRODUCT FROM PROCESS AT MACHINE    |
| H19 | SERV. SWITCH IN ON POS.            | H46 | INCORRECT POS., PRODUCT PIPE          |
| H20 | TOO LOW PRESS. LUB. OIL            | H47 | INCORRECT POS., CLEANING PIPE         |
| H21 | TOO LOW LEVEL LUB. OIL             | H48 | INCORRECT POS., AP VALVE B            |
| H22 | TOO HIGH TEMP. HYDRAULIC OIL       | H49 | TOO LOW LEVEL, PER. BATH, PEROXIDE    |
| H23 | TOO LOW LEVEL HYDRAULIC OIL        | H50 | TOO LOW LEVEL, PER. BATH, WATER       |
| H24 | MACHINE SPEED TOO HIGH             | H51 | LOW TEMP. ELEMENT, LS                 |
| H25 | MEMORY BATTERY LOW                 | H52 | TOO LOW TEMP., PEROXIDE               |
| H26 | -                                  | H53 | TOO LOW TEMP., PER. BATH, WATER       |
| H27 | -                                  | H54 | INCORR. POS., BOTTOM COVER, PER. BATH |
| H28 | -                                  | H55 | POS. PRINTED DESIGN OUT OF LIMITS     |
| H29 | -                                  | H56 | INCORR. POS., DRAIN PIPE, PER. BATH   |
| H30 | HIGH LEVEL, SEPARATORS             | H57 | INCORR. POS., CLEANING CUP            |
| H31 | TOO LOW TEMP. AT AIR HEATER        | H58 | FAULT IH UNITS, TS                    |
| H32 | TOO LOW PRESS. STERILE AIR         | H59 | CONGESTION MONITOR FAULT              |
| H33 | INCORRECT POS., SUCTION VALVE      | H60 | TOO LOW LEVEL, PEROXIDE TANK          |
| H34 | SPRAY TIME OUT OF LIMITS           | H61 | ROTATION FAULT, FF                    |
| H35 | TOO LOW TEMP. AT AIR KNIFE         | H62 | TOO LOW LEVEL, CLEANING TRAY          |
| H36 | INCORRECT POS. OF INLET VALVE      | H63 | PLE - EQUIPMENT                       |

Description: MOUNTING DRAWING, CONTROL PANEL

Machine TBA/9-14.01 S.A. 52471-14.01

Drawing Remarks

Introduced with AM No	19260	Date	930310	Sign	HK/JTH
Issue					
AM No					
Date					
Sign					

A B C D E G H K L M N O P R S T U V X Y Z

R.M. Halliday

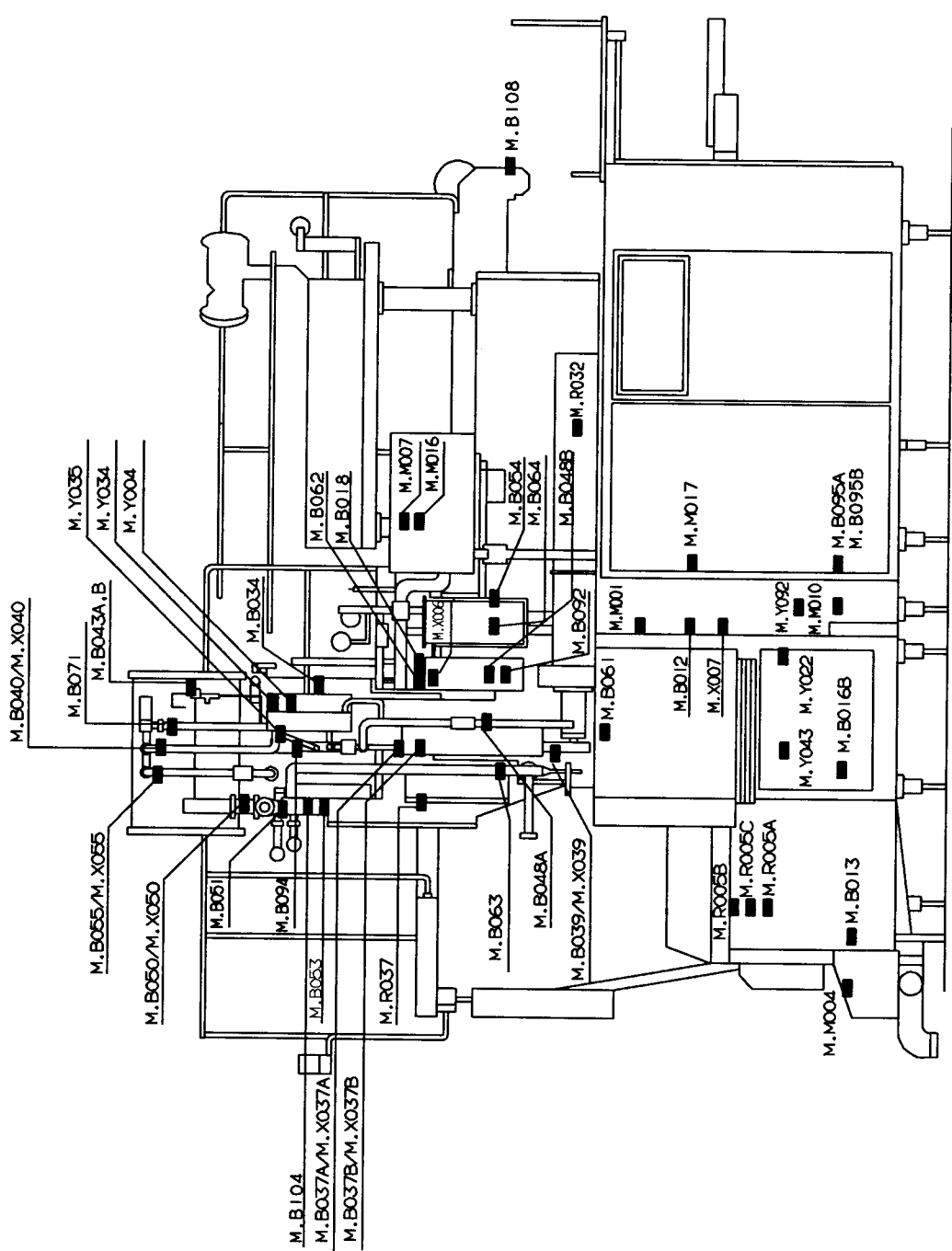

INTRODUCED BY: A	DATE: 19260	SERIAL: 930310	REVISION: HK/UTH
TABLE NO: 20080			
DATE: 930608			
BY: HK/PSG			
DRAWING REMARKS			
DESCRIPTION: MOUNTING DRAWING, MACHINE			MACHINE: 52471-15:01

This drawing must not without the consent of Tetra Pak be copied, transmitted or disclosed to any third party.

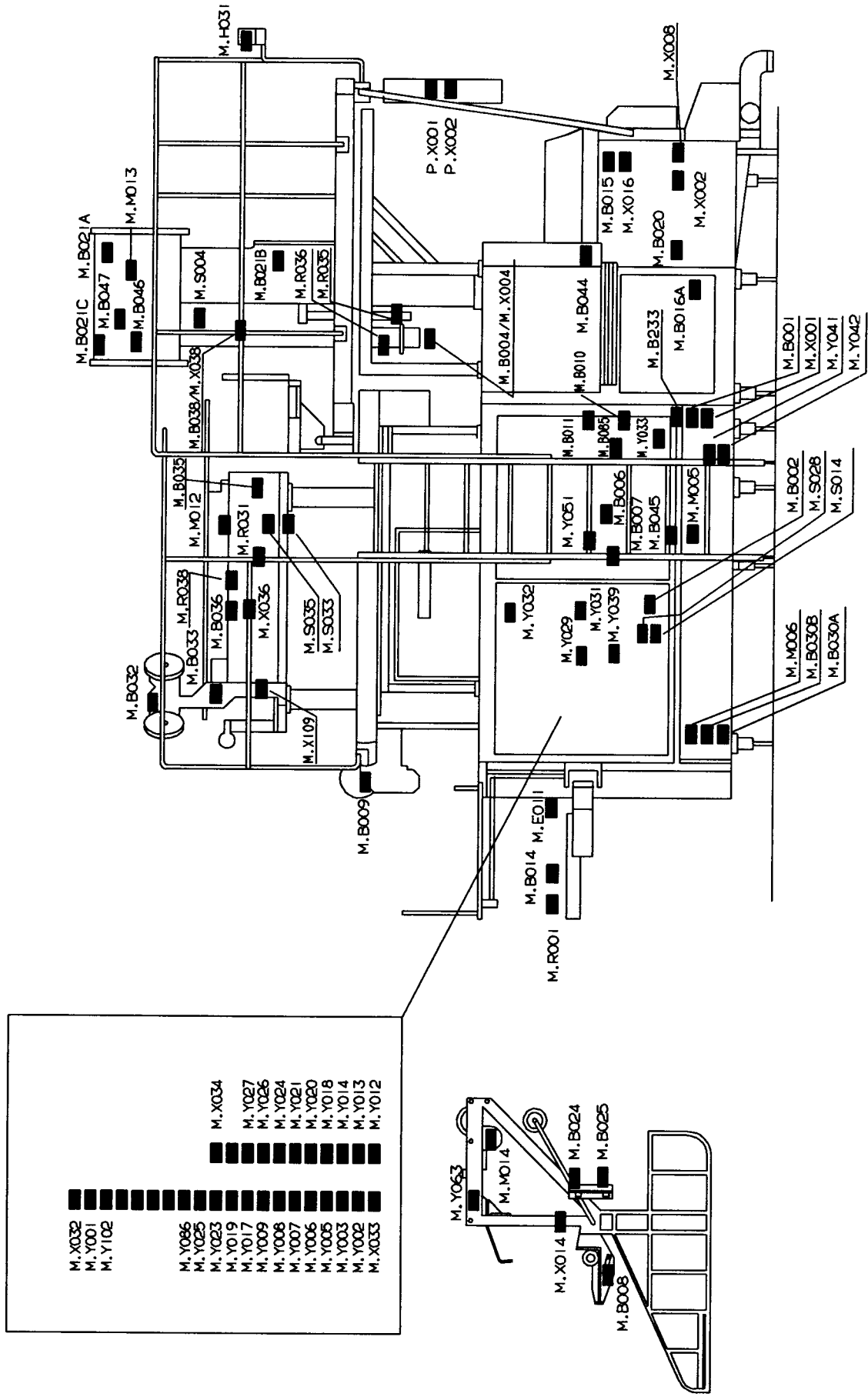

- M.X032
- M.Y001
- M.Y102
- M.Y086
- M.Y026
- M.Y023
- M.Y019
- M.Y017
- M.Y009
- M.Y008
- M.Y007
- M.Y006
- M.Y005
- M.Y003
- M.Y002
- M.X033
- M.X034
- M.Y027
- M.Y026
- M.Y024
- M.Y021
- M.Y020
- M.Y018
- M.Y014
- M.Y013
- M.Y012
- M.Y063
- M.X014
- M.MO14
- M.B024
- M.B025
- M.B008

INTRODUCED WITH AM NO.	19260	DATE	930310	STEP	HK/JUTH
TITLE					
AM NO.					
DATE					
STEP					
ALTERNATIONS ONLY IN CADAM					
DESCRIPTION:			MOUNTING DRAWING, MACHINE		
MACHINE:			TBA/9-1401 S.A		
			52471-16:01		

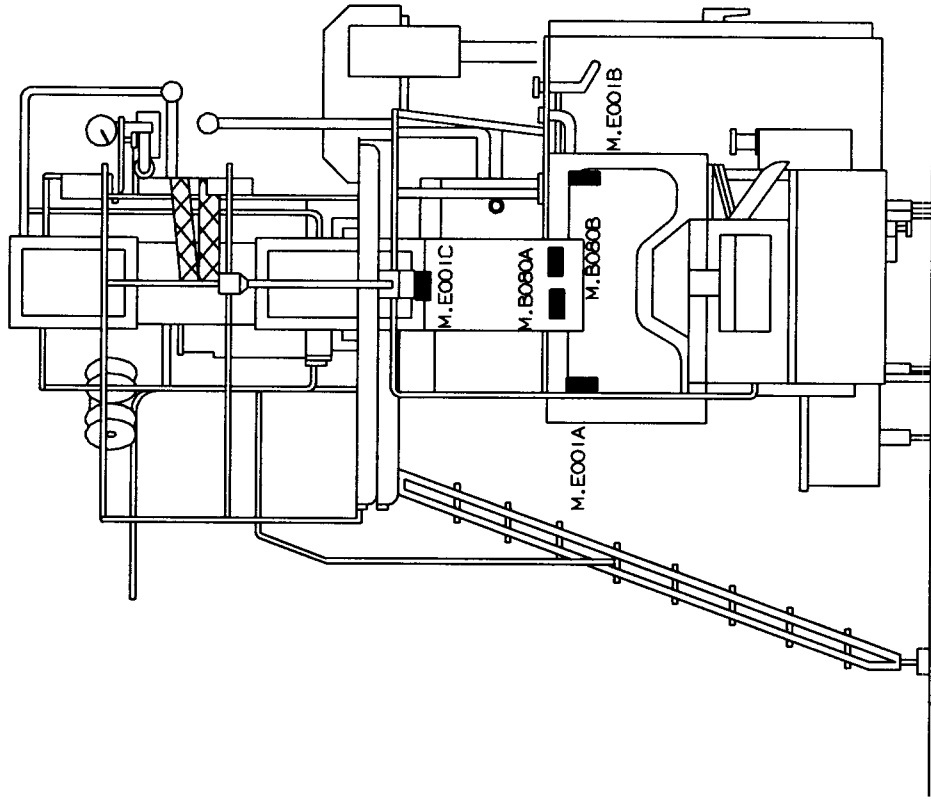

INTRODUCED WITH AM NO.	19260	DATE	930310	STBY.	HK/ZUTH
TABLE					
AM NO.					
DATE					
STBY.					
ALTERATIONS ONLY IN CADAM					
DRAWING REMARKS					
DESCRIPTION:				MOUNTING DRAWING, MACHINE	
MACHINE:				TBA/9-1401 S.A	
				52471-17:01	

This drawing must not without the consent of Tetra Pak be copied, transmitted or disclosed to any third party.

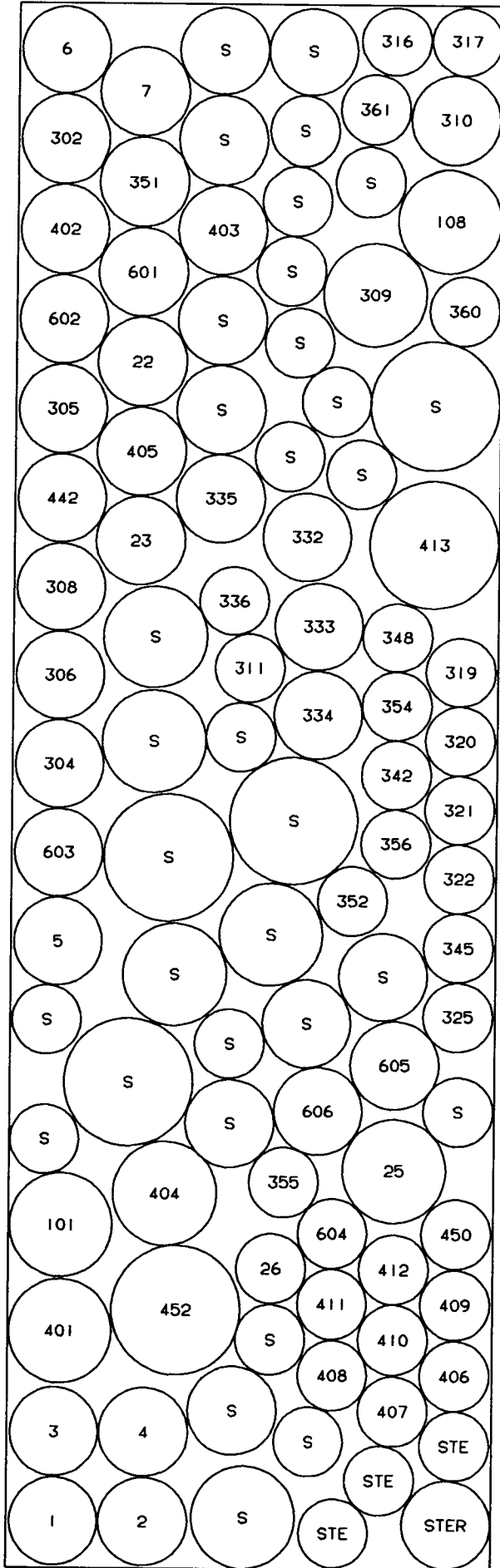

CABLE LEAD-IN EL-CABINET

○ 8, 17, 18, 19, 447, 448.

CABLES THROUGH MACHINE BODY HAND RAIL

TOP VIEW OF CONTROL CABINET

INTRODUCED BY: M. NO.	19260	DATE	930310	REV.	HK/UTH
TABLE					
M. NO.					
DATE					
BY:					
ALTERATIONS ONLY IN CADAM					
DESCRIPTION:				MOUNTING DRAWING	
MACHINE:				TBA/9-1401 S.A	
				52471-18:01	

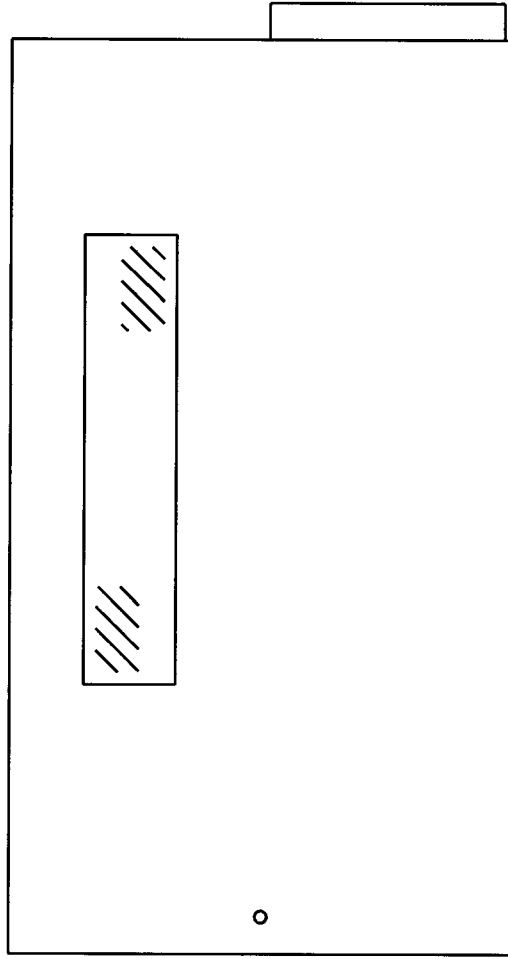

FRONT VIEW

REFERENCE WITH NO. NO.	19260	DATE	9.30.310	BY	HK/UTH
NO.					
DATE					
SIGN.					
ALTERATIONS ONLY IN CADAM					
				DESCRIPTION:	MOUNTING DRAWING
				MACHINE:	TPIH CABINET
					52471-20:01
DRAWING REMARKS					

This drawing must not, without the consent of Tetra Pak, be copied, transmitted or disclosed to any third party.

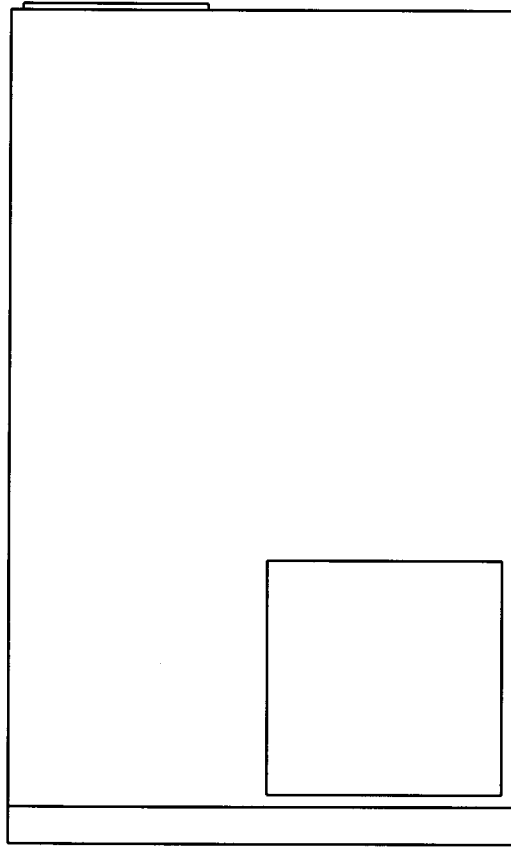

RIGHT HAND VIEW

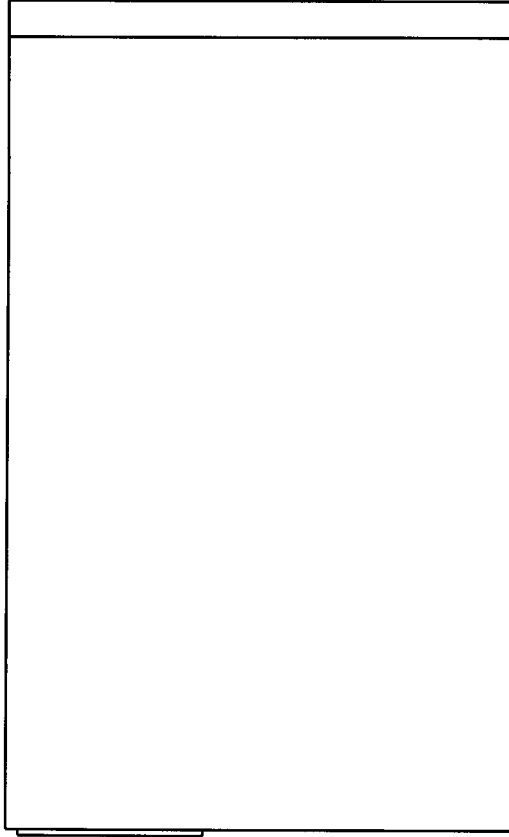

LEFT HAND VIEW

INTERFERENCE WITH AN NO.	19260	DATE	930310	DATE	HK/JTH	DESCRIPTION	MOUNTING DRAWING	
ITEM								
AN NO.								
DATE								
BY								
REVISIONS								
DRAWING REMARKS							MACHINE	TPIH CABINET
								52471-21:01

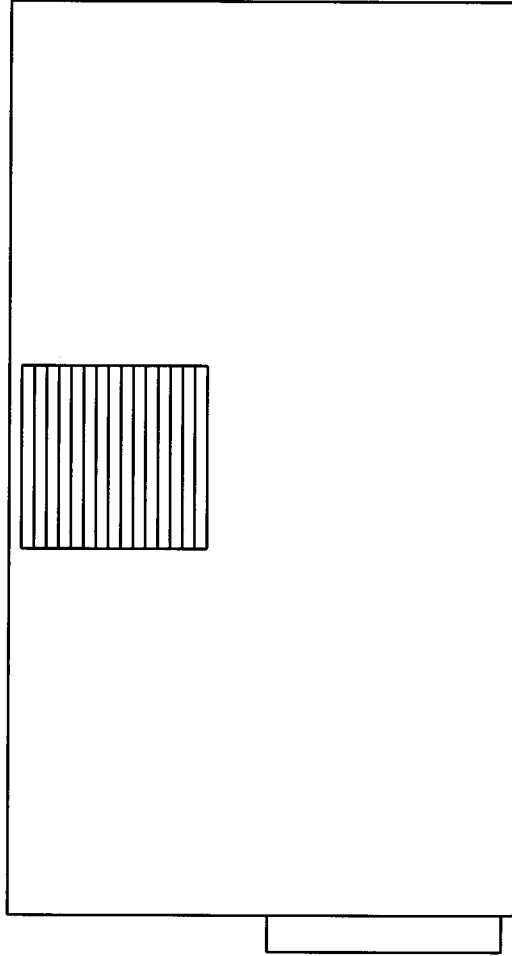

REAR VIEW

INTRODUCTION BY THE DR. NO.	19260	DATE	930310	SCALE	HK/UTH	DESCRIPTION	MOUNTING DRAWING
DATE		DATE		DATE		DATE	
BY		BY		BY		BY	
CHECKED		CHECKED		CHECKED		CHECKED	
				DRAWING REMARKS			
				MACHINE: TPIH CABINET			
				52471-22:01			

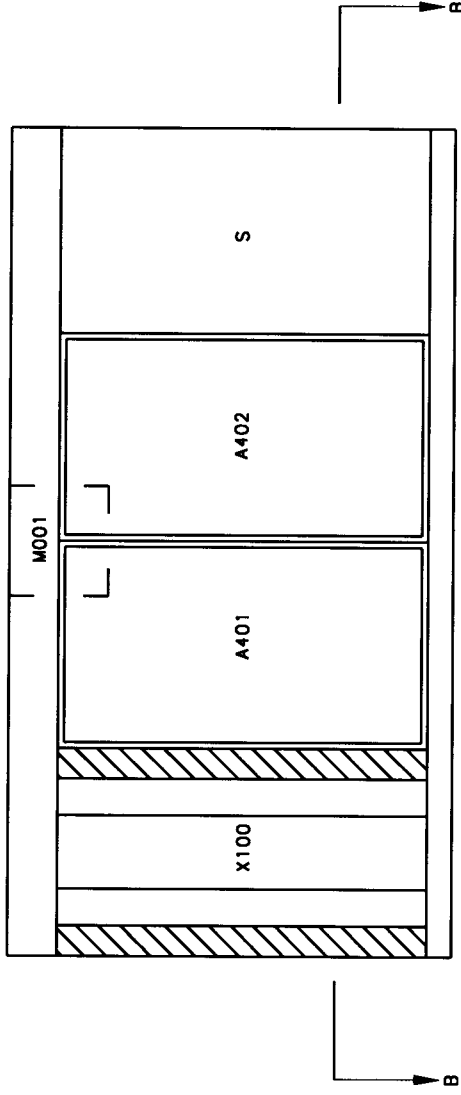

INSIDE VIEW

REFERENCE IN THE DRAWING	19260	DATE	9.30.310	BY	HK/UTH
DATE					
BY					
CHKD.					
APP.					
DRAWING REMARKS					
DESCRIPTION:				MOUNTING DRAWING	
MACHINE:				TPIH CABINET	
				52471-23:01	

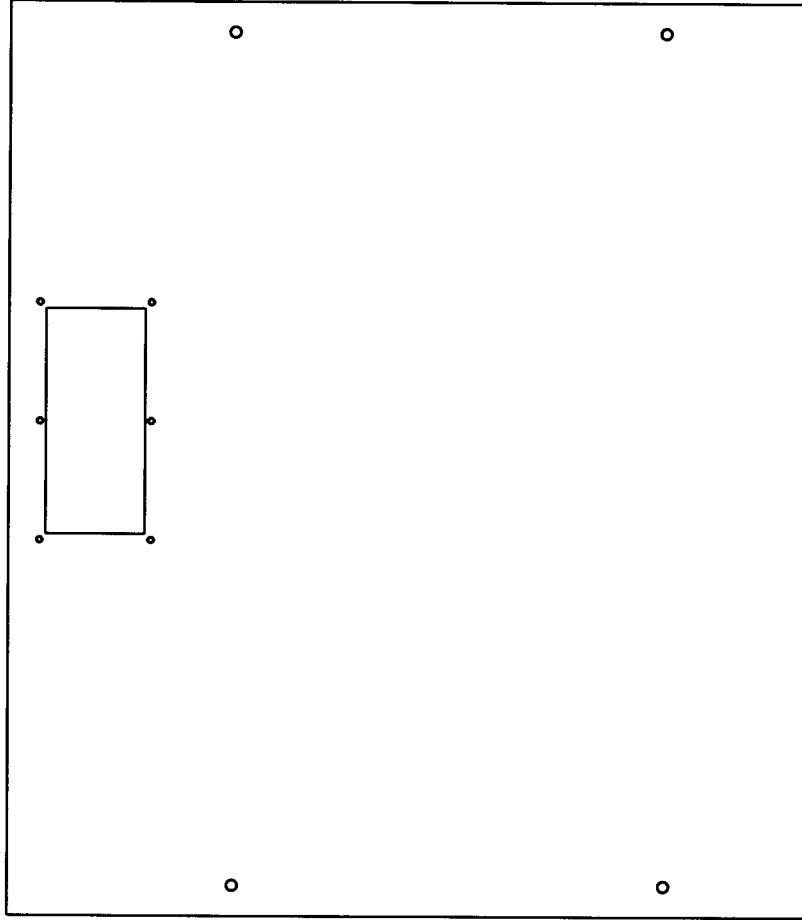

VIEW B-B

INTENDED BY THE DR. NO.	19260	DATE	930310	DRW.	HK/ZUTH	DESCRIPTION	MOUNTING DRAWING
DATE		DATE		DATE		MACHINE	TPH CABINET
DATE		DATE		DATE		DRAWING REMARKS	
DATE		DATE		DATE		52471-24:01	

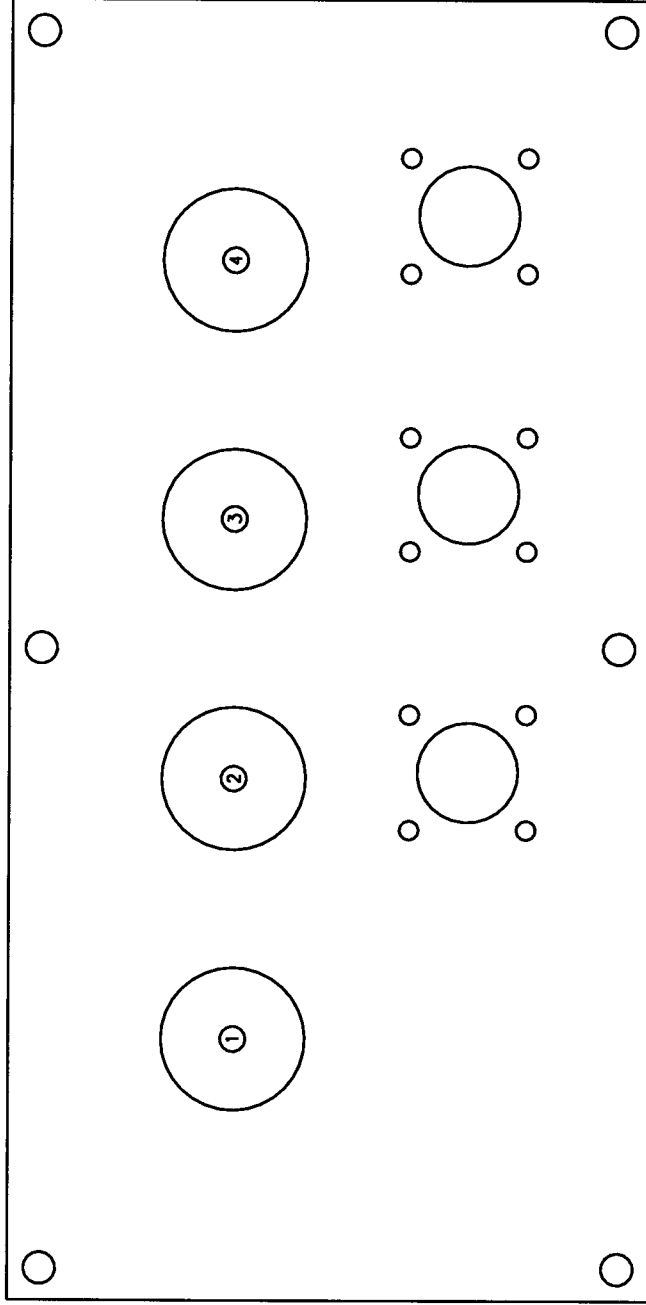

CABLE LEAD IN FROM THE INSIDE OF THE TPIH-CABINET

INTENDED BY: <b>JA</b>	DATE: <b>19260</b>	QTY: <b>930310</b>	UNIT: <b>HK/UTH</b>	DESCRIPTION: <b>MOUNTING DRAWING</b>
REF: <b>20080</b>				
DATE: <b>930505</b>				
BY: <b>HK/PSG</b>				MACHINE: <b>TPIH CABINET</b>
				52471-25:01
DRAWING REMARKS				

This drawing must not without the consent of Tetra Pak, be copied, transmitted or disclosed to any third party.

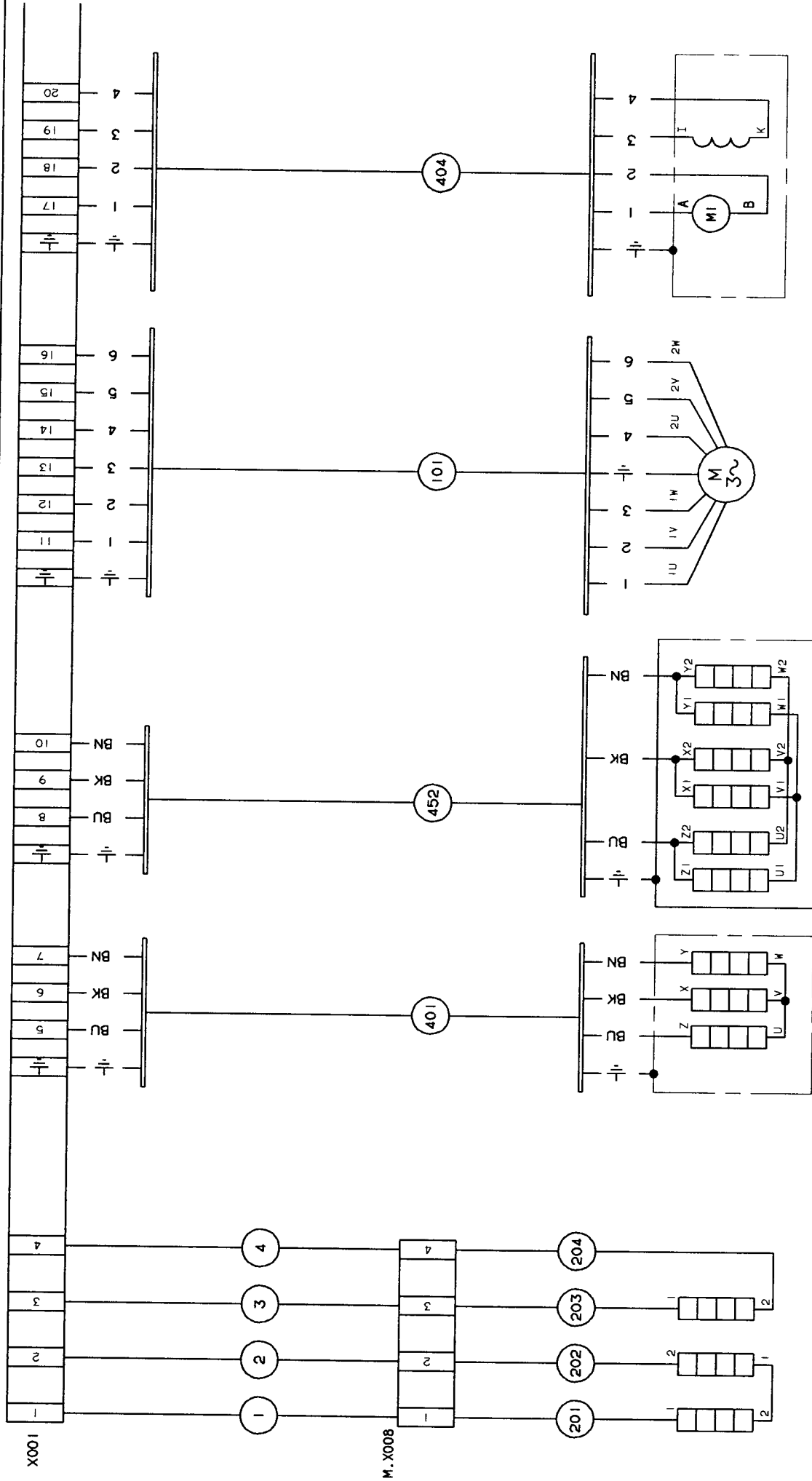

M.R005B-C M.R005A  
FLAP SEALING BOTTOM

M.R036  
PEROXISIDE BATH WATER

M.R032  
AIR SUPER HEATER

M.0001  
MAIN MOTOR

M.0013  
BENDING ROLLER

FOOT NOTE: CABLE CORES ARE TO BE MARKED WITH TERMINAL DESIGNATION

INTRODUCED WITH AM NO.	19260	DATE	930310	REV.	HK/UTH
TABLE					
AM NO.					
DATE					
REV.					
ALTERATIONS ONLY IN CADAM					
DESCRIPTION:			CONNECTION DIAGRAM		
MACHINE:			TBA/9-1401 S.A		
DRAWING REMARKS			61232-05:01		

This drawing must not without the consent of Tetra Pak be copied, transmitted or disclosed to any third party.

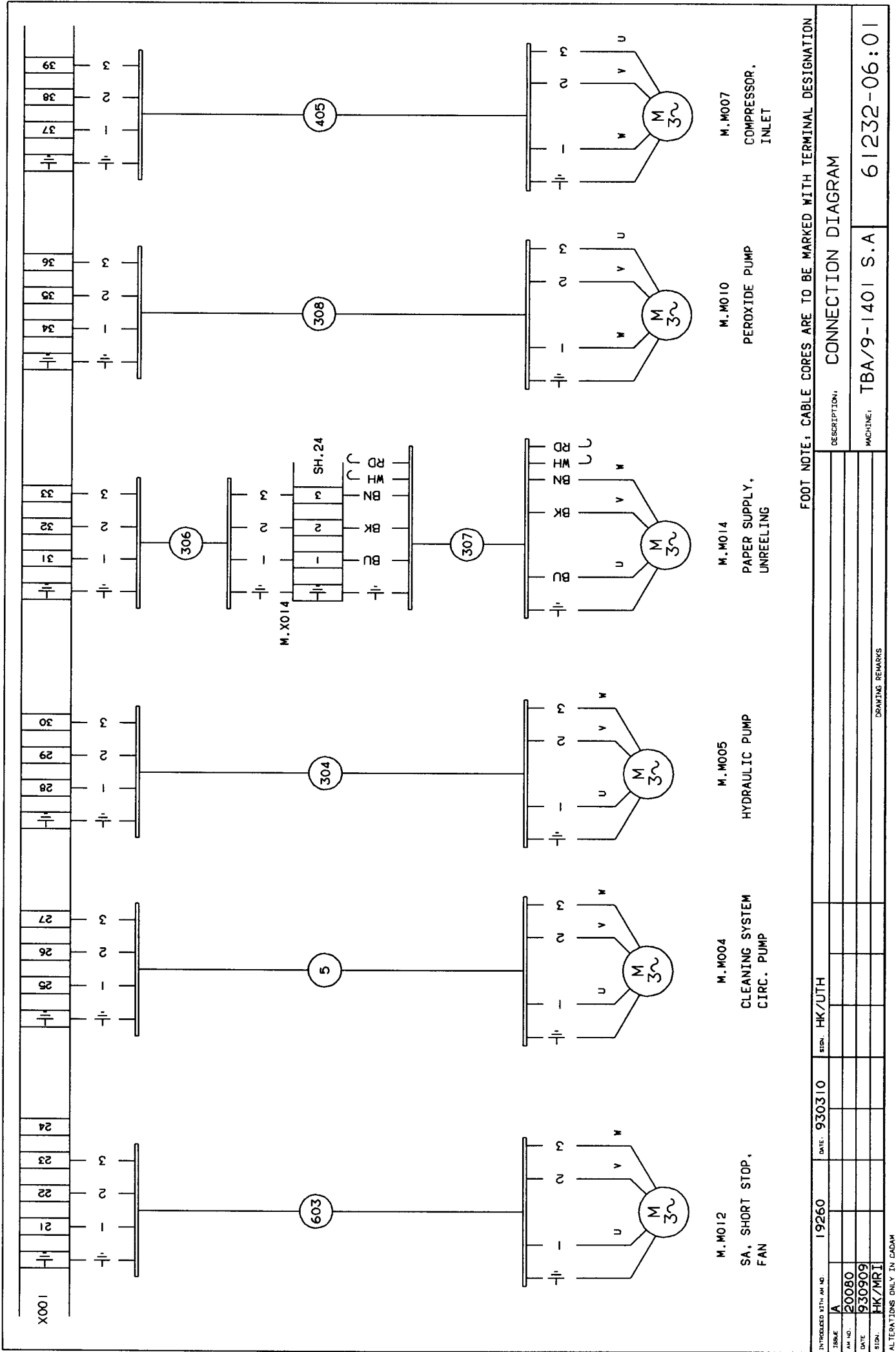

FOOT NOTE: CABLE CORES ARE TO BE MARKED WITH TERMINAL DESIGNATION

INTEGRATED WITH AM. NO.	DATE	930310	BY	HK/LJH	DESCRIPTION	CONNECTION DIAGRAM
A	19260					
AM. NO.	20080					
DATE	930909					
SIGN.	HK/MRI					
MACHINE						TBA/9-1401 S.A
DRAWING REMARKS						61232-06:01

This drawing must not without the consent of Tetra Pak, be copied, transmitted or disclosed to any third party.

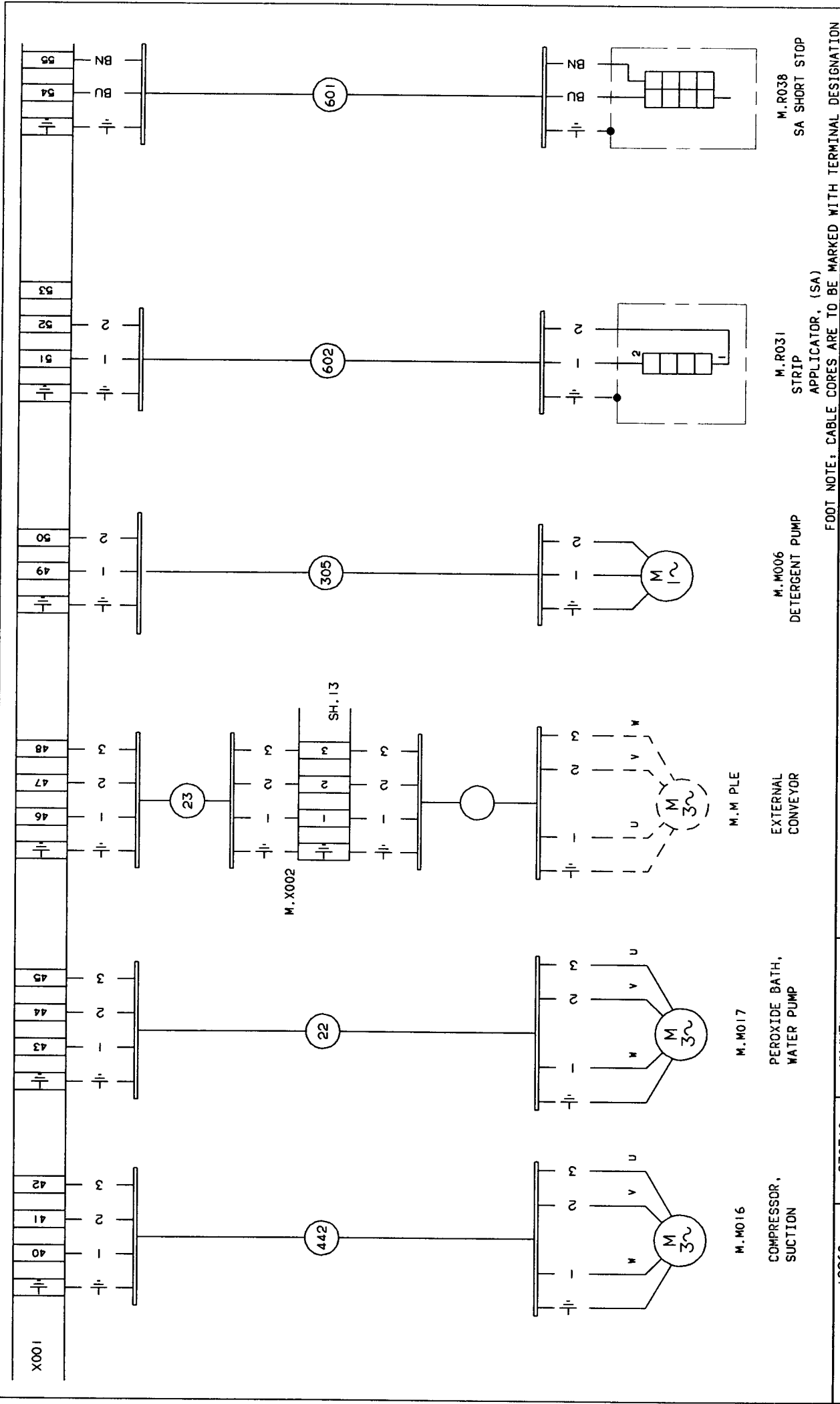

INTRODUCED WITH AM. NO.	DATE	930310	SIGN.	HK/ZUTH	DESCRIPTION:	CONNECTION DIAGRAM
ISSUE A	19260				FOOT NOTE: CABLE CORES ARE TO BE MARKED WITH TERMINAL DESIGNATION	
AM. NO. 20406						
DATE 931015						
SIGN. HK/MRT						
ALTERATIONS ONLY IN CADAM						MACHINE: TBA/9-1401 S.A
						61232-07:01

This drawing must not without the consent of Tetra Pak be copied, transmitted or disclosed to any third party.

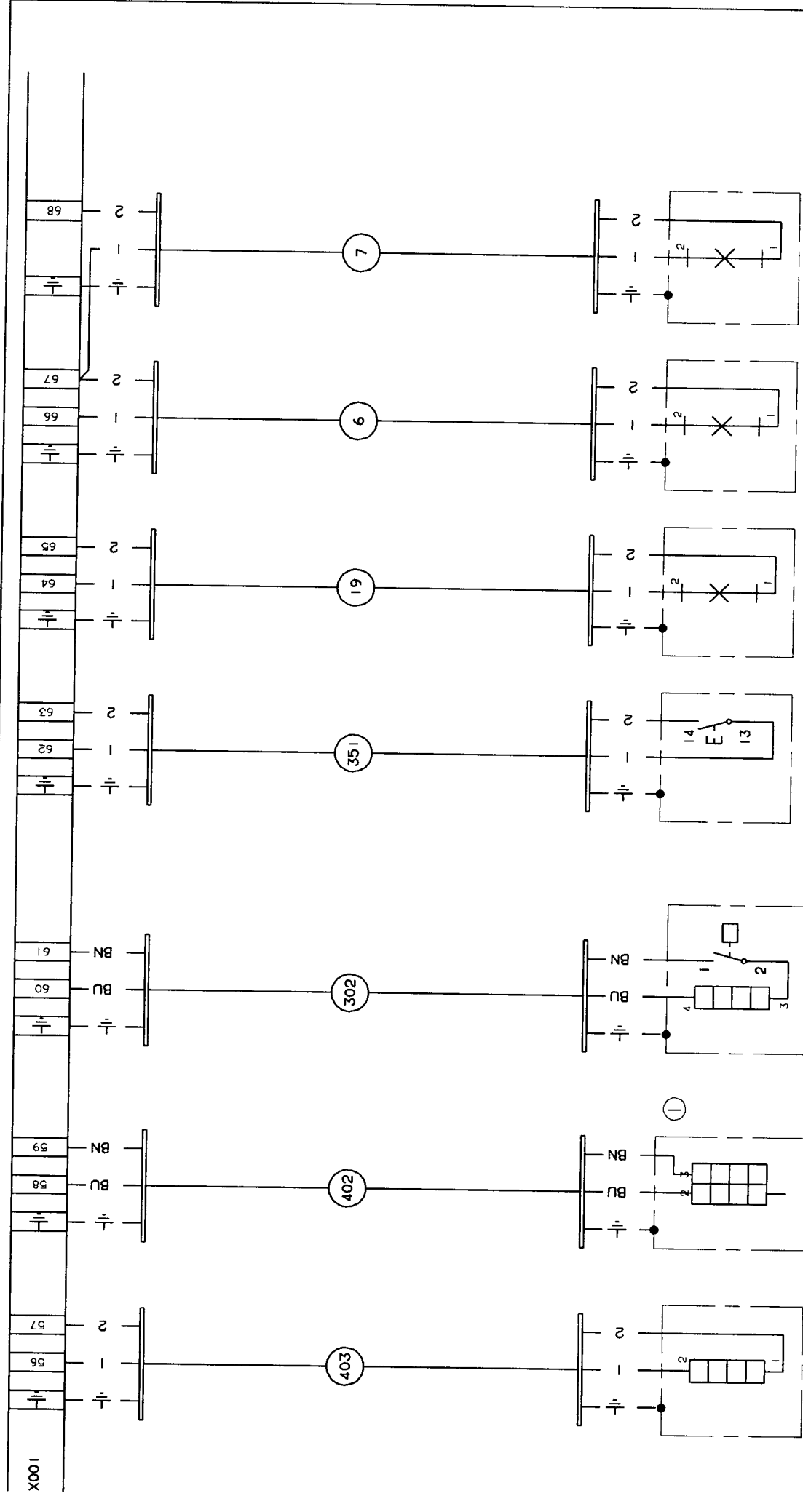

M.8035  
LONGITUDINAL  
SEALING (LS)

M.R037  
LS SHORT STOP

M.B014 M.R001  
SPLICER, PAPER

M.S028  
LIGHT SWITCH

M.E001C  
JAW SYSTEM,  
FRONT

M.E001A  
JAW SYSTEM,  
LEFT

M.E001B  
JAW SYSTEM,  
RIGHT

INTRODUCED BY: AM NO.	19260	DATE:	930310	BY:	HK/LUTH	ELEMENT PIN CONFIGURATION	1-2 = 1200W	DESCRIPTION:	CONNECTION DIAGRAM	
DATE:		DATE:		DATE:		1-3 = 700W				
BY:		BY:		BY:		2-3 = 450W				
ALTERATIONS ONLY IN CADAM							MACHINE:	TBA/9-1401 S.A		61232-08:01

FOOT NOTE: CABLE CORES ARE TO BE MARKED WITH TERMINAL DESIGNATION





This drawing must not without the consent of Tetra Pak, be copied, transmitted or disclosed to any third party.

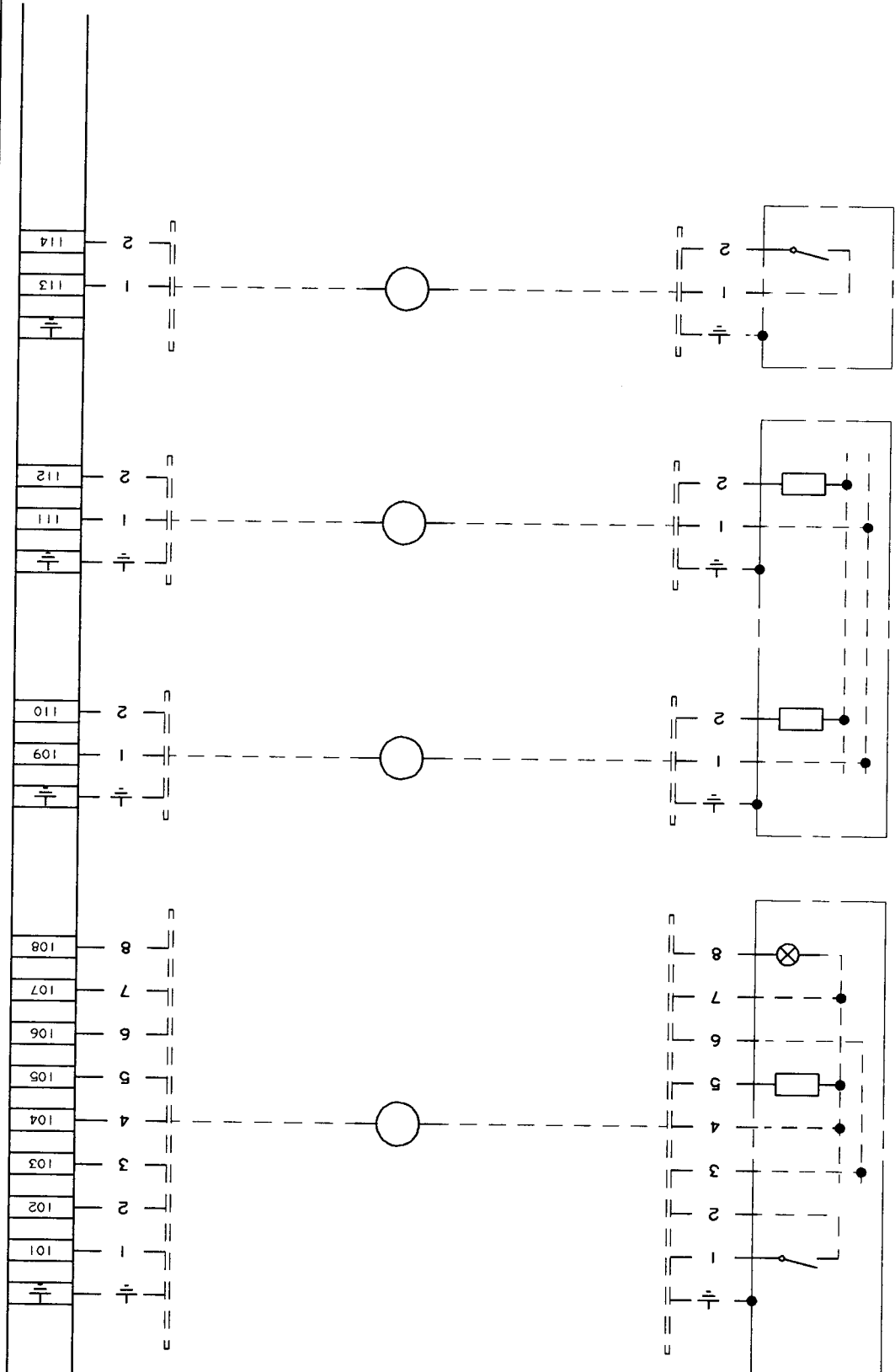

M.S28

STERILE SIGNALS

PROD. AT MACHINE  
READY FOR PRODUCTION  
AB PROD.

READY FOR CIP  
SIGNAL FROM FILLING

SIGNAL CIP-CLEANING ON

FOOT NOTE: CABLE CORES ARE TO BE MARKED WITH TERMINAL DESIGNATION

INTRODUCED WITH AM NO.	19260	DATE	930310	BY	HK/UTH
TABLE AM NO.					
DATE					
BY					
ALTERATIONS ONLY IN CADAM					
DESCRIPTION:				CONNECTION DIAGRAM	
MACHINE:				TBA/9-1401 S.A	
				61232-12:01	

This drawing must not without the consent of Tetra Pak be copied, transmitted or disclosed to any third party.

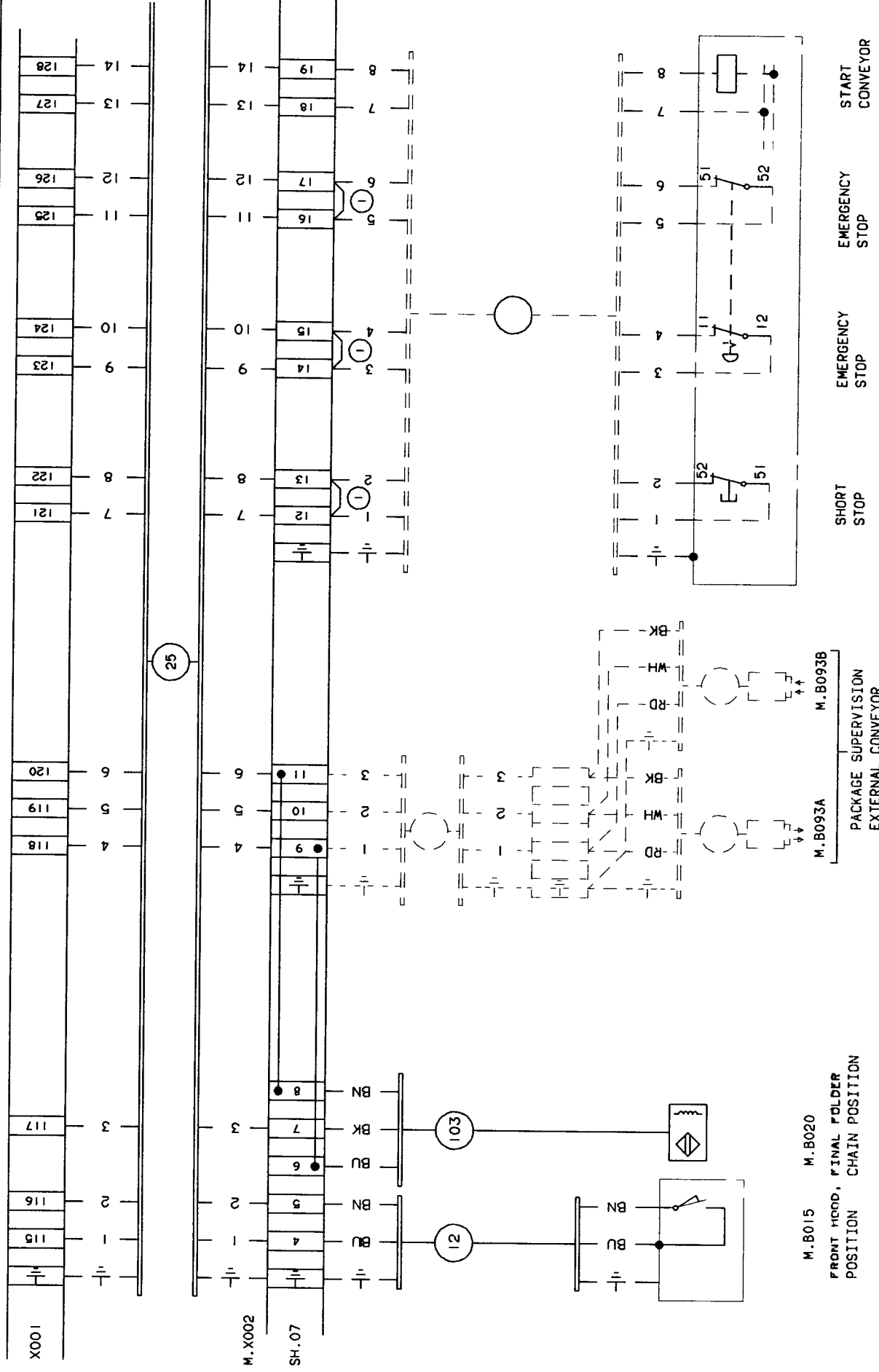

INTRODUCED WITH AM NO.	19260	DATE	930310	STEP	HK/UTH
TITLE	A				
AM NO.	20080				
DATE	930909				
STEP	HK/MRI				

FOOT NOTE: CABLE CORES ARE TO BE MARKED WITH TERMINAL DESIGNATION

DESCRIPTION: CONNECTION DIAGRAM

MACHINE: TBA/9-1401 S.A

61232-13:01

ALTERATIONS ONLY IN CADAM

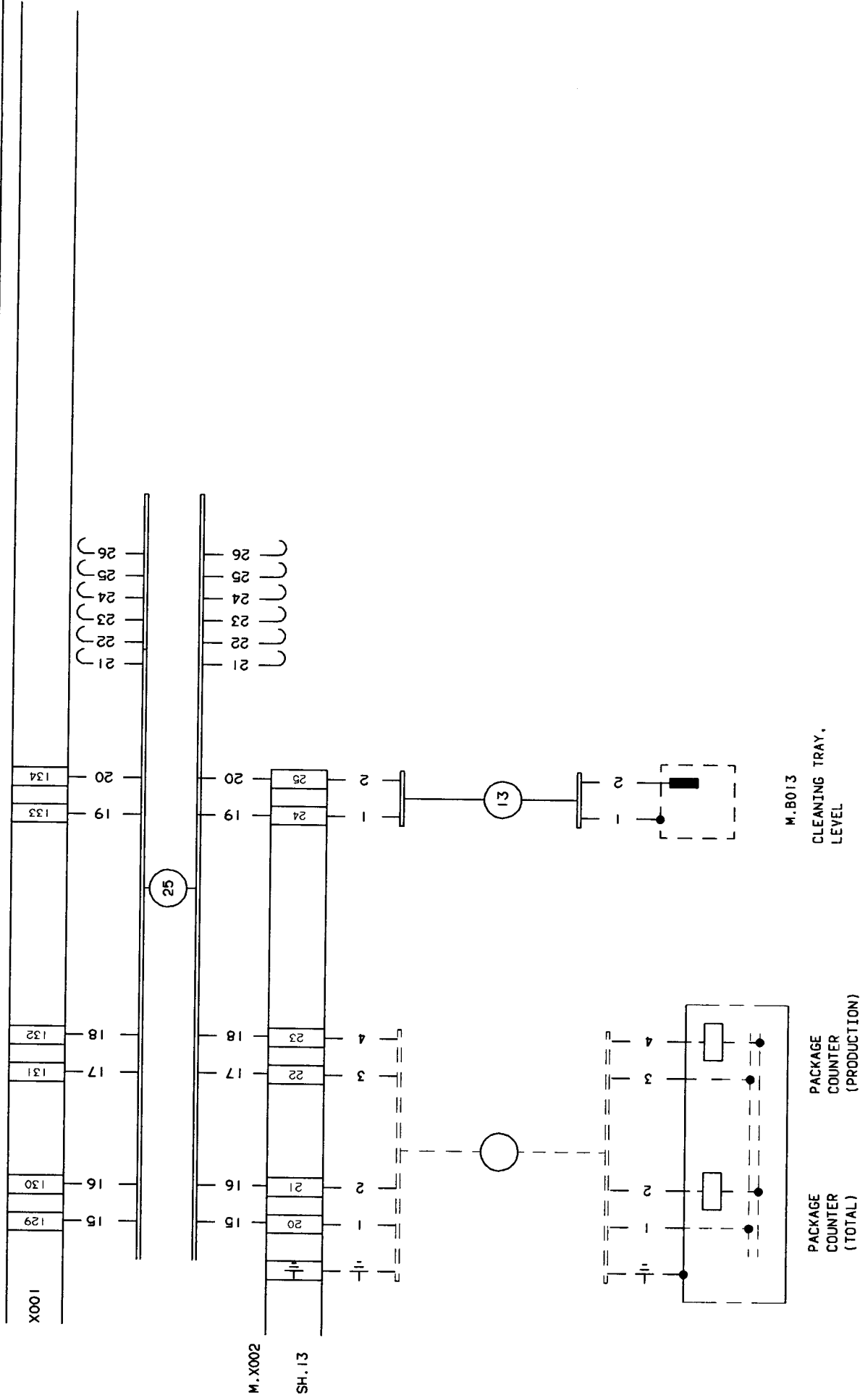

FOOT NOTE: CABLE CORES ARE TO BE MARKED WITH TERMINAL DESIGNATION

INTRODUCED WITH AM. NO.	19260	DATE:	930310	SIGN:	HK/UTH
TITLE					
AM. NO.					
DATE					
SIGN.					
ALTERATIONS ONLY IN C/DRAW					
				DESCRIPTION:	CONNECTION DIAGRAM
				MACHINE:	TBA/9-1401 S.A
					61232-14:01

Ⓢ REMOVE WHEN PLE IS INSTALLED.

PACKAGE COUNTER (TOTAL)

PACKAGE COUNTER (PRODUCTION)

M.B013  
CLEANING TRAY,  
LEVEL

This drawing must not without the consent of Tetra Pak, be copied, transmitted or disclosed to any third party.

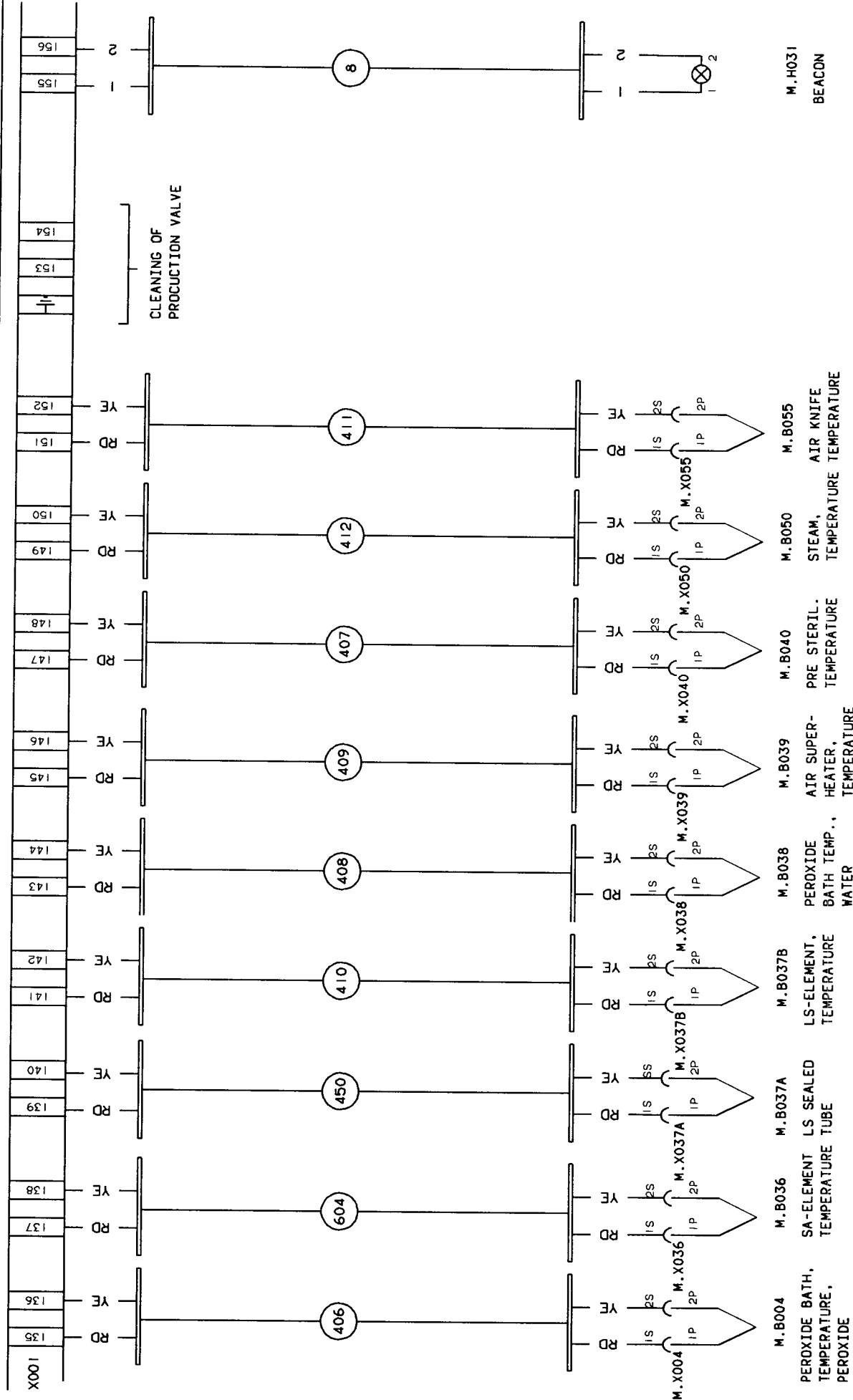

FOOT NOTE: CABLE CORES ARE TO BE MARKED WITH TERMINAL DESIGNATION

INTRODUCTION BY: AM. NO.	19260	DATE:	930310	BY:	HK/JUTH
DESCRIPTION:	CONNECTION DIAGRAM				
MACHINE:	TBA/9-1401 S.A				
DRAWING REMARKS:	61232-15:01				
ALTERATIONS ONLY IN CADAM					

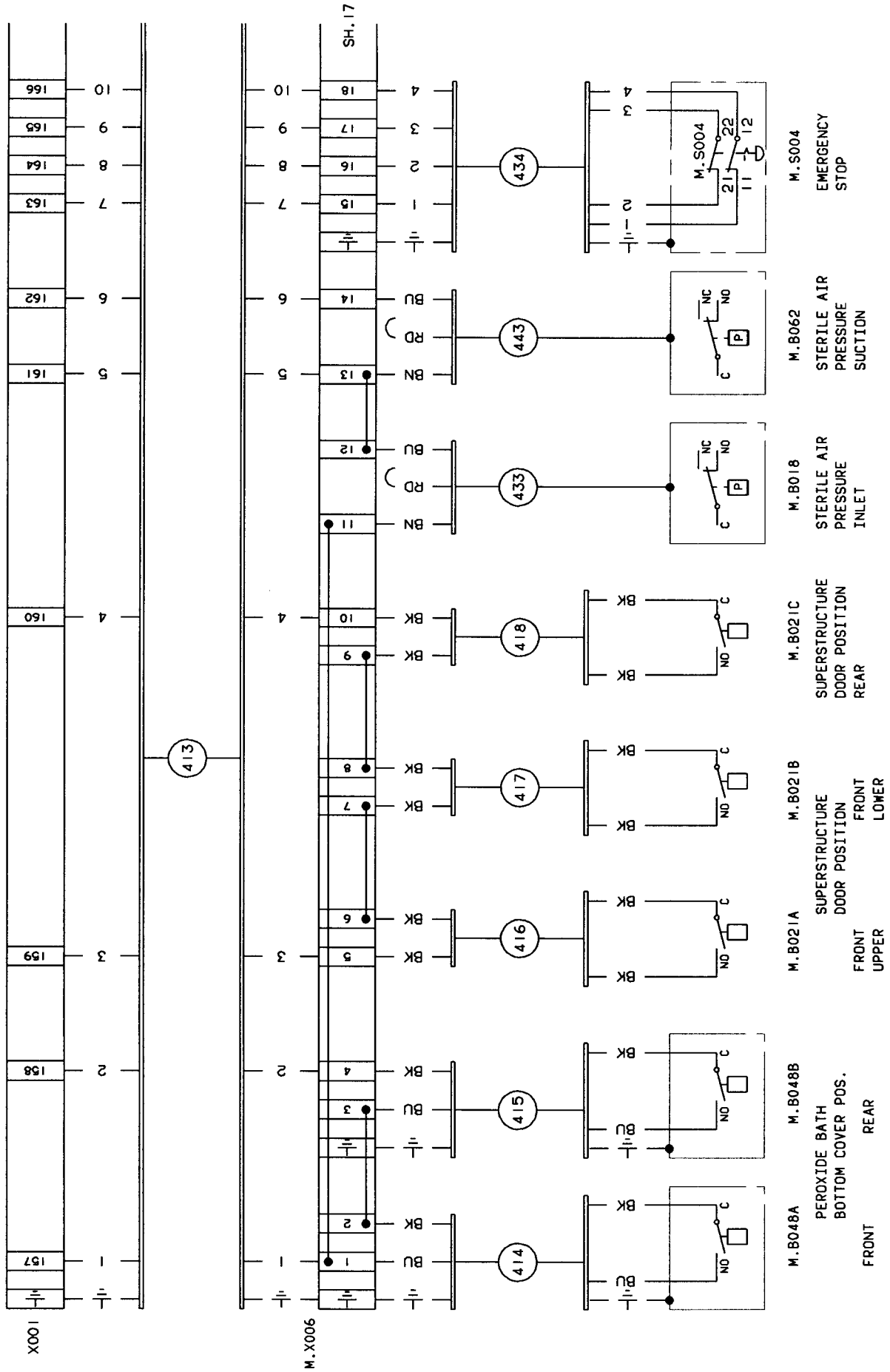

FOOT NOTE: CABLE CORES ARE TO BE MARKED WITH TERMINAL DESIGNATION

INTRODUCED WITH AM. NO.	19260	DATE:	930310	REVN.	HK/UJH
TITLE	A				
AM. NO.	20080				
DATE	930909				
DRAWN	HK/MRI				
ALTERATIONS ONLY IN CADAM					
DRAWING REMARKS					
DESCRIPTION: CONNECTION DIAGRAM					
MACHINE: TBA/9-1401 S.A					
61232-16:01					

This drawing must not without the consent of Tetra Pak be copied, transmitted or disclosed to any third party.

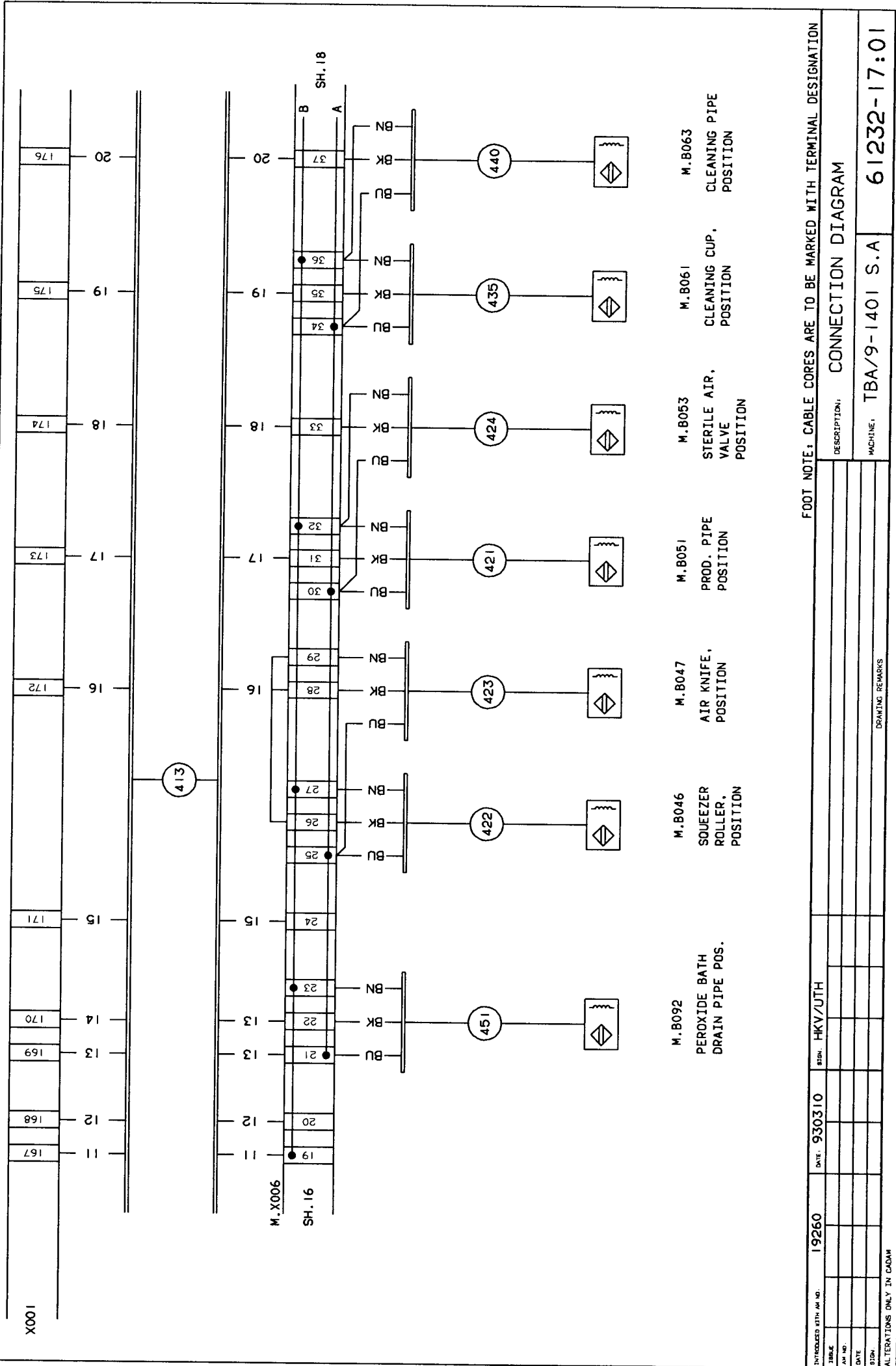

FOOT NOTE: CABLE CORES ARE TO BE MARKED WITH TERMINAL DESIGNATION

INTENDED BY	DATE	NO.	BY	CHKD./JTH	DESCRIPTION	CONNECTION DIAGRAM
	19260	930310				
ALTERATIONS ONLY IN CADAM						
						MACHINE:
						TBA/9-140I S.A
						DRAWING NO.
						61232-17:01

This drawing must not, without the consent of Tetra Pak, be copied, transmitted or disclosed to any third party.

X001

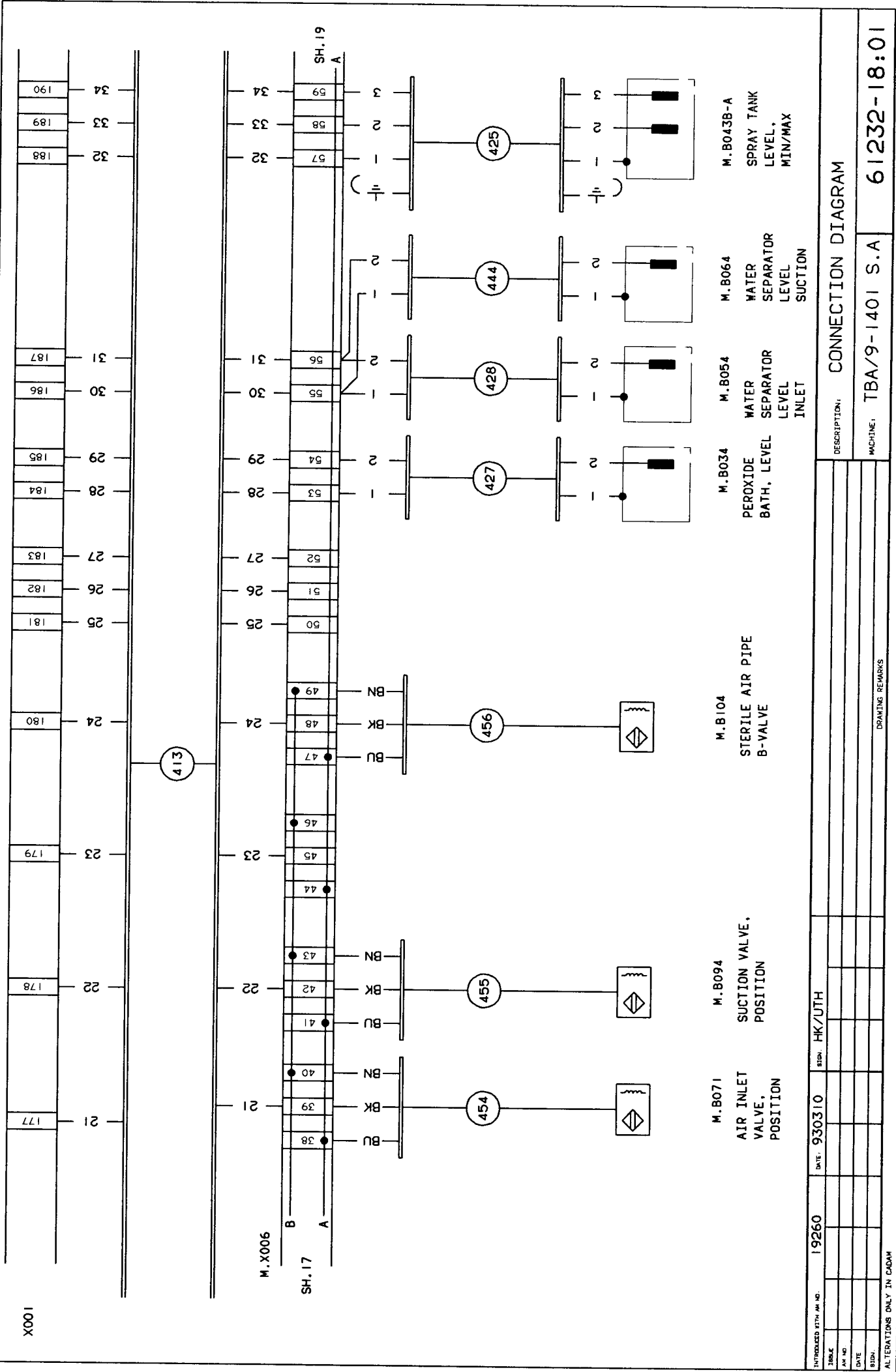

- M. B071 AIR INLET VALVE, POSITION
- M. B094 SUCTION VALVE, POSITION
- M. B104 STERILE AIR PIPE B-VALVE
- M. B034 PEROXIDE BATH, LEVEL
- M. B054 WATER SEPARATOR LEVEL INLET
- M. B064 WATER SEPARATOR LEVEL SUCTION
- M. B043B-A SPRAY TANK LEVEL, MIN/MAX

INTRODUCED WITH AN NO.	19260	DATE	930310	BY	HK/JTH
TITLE	CONNECTION DIAGRAM				
AN NO.					
DATE					
BY					
DESCRIPTION	TBA/9-140I S.A				
ALTERATIONS ONLY IN CADAM	MACHINE: 61232-18:01				
DRAWING REMARKS					

# Tetra Pak

LUND SWEDEN

This drawing must not without the consent of Tetra Pak be copied, transmitted or disclosed to any third party.

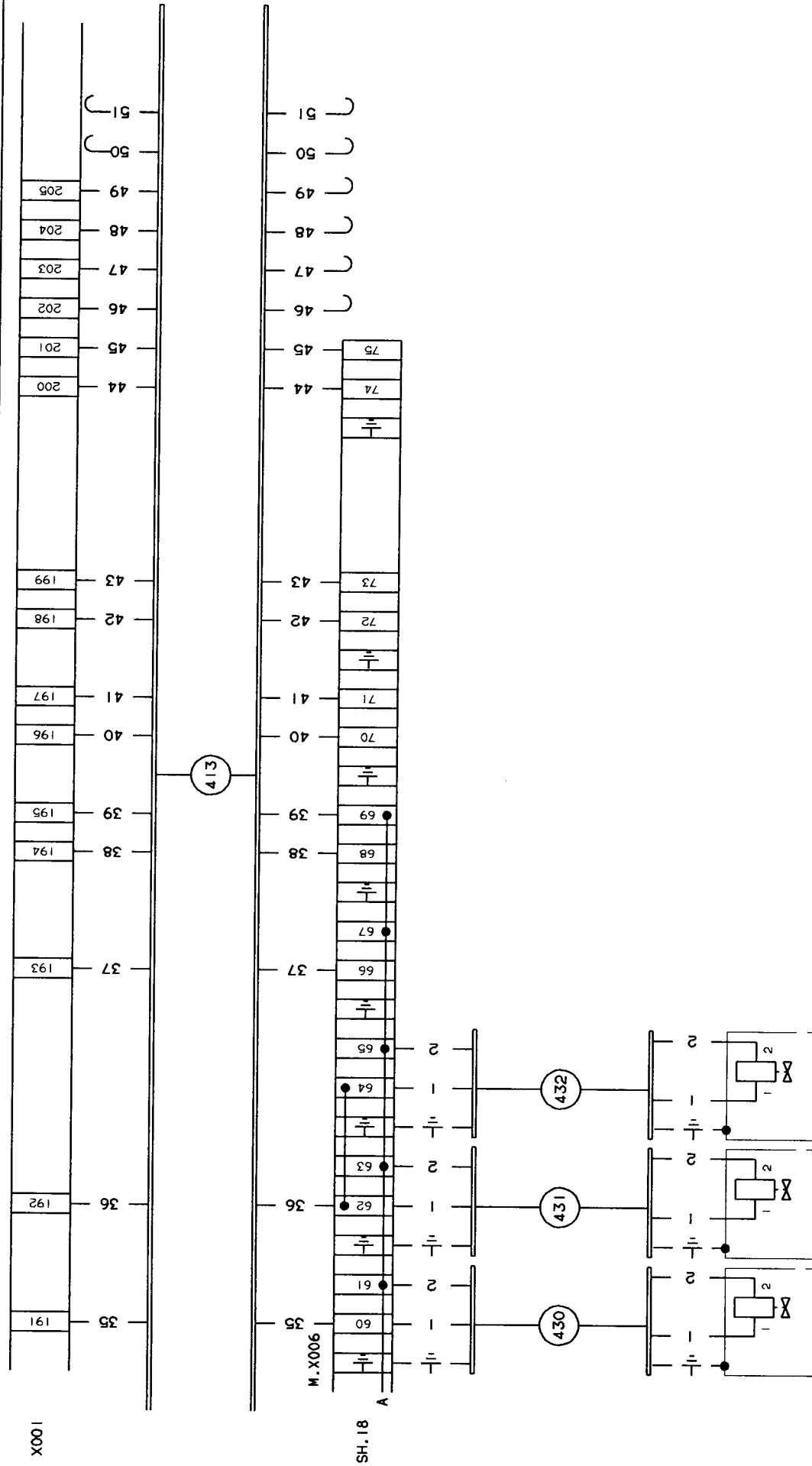

- M.Y034 SPRAY TANK, FILLING
- M.Y035 SPRAY TANK, SPRAYING PEROXIDE
- M.Y004 SPRAY TANK, SPRAYING AIR

INTRODUCED WITH AM. NO.	19260	DATE	930310	SIGN.	HK/JUTH
TABLE					
AM. NO.					
DATE					
SIGN.					
ALTERATIONS ONLY IN CADAM					
				DESCRIPTION:	CONNECTION DIAGRAM
				MACHINE:	TBA/9-1401 S.A
				DRAWING NO. 61232-19:01	

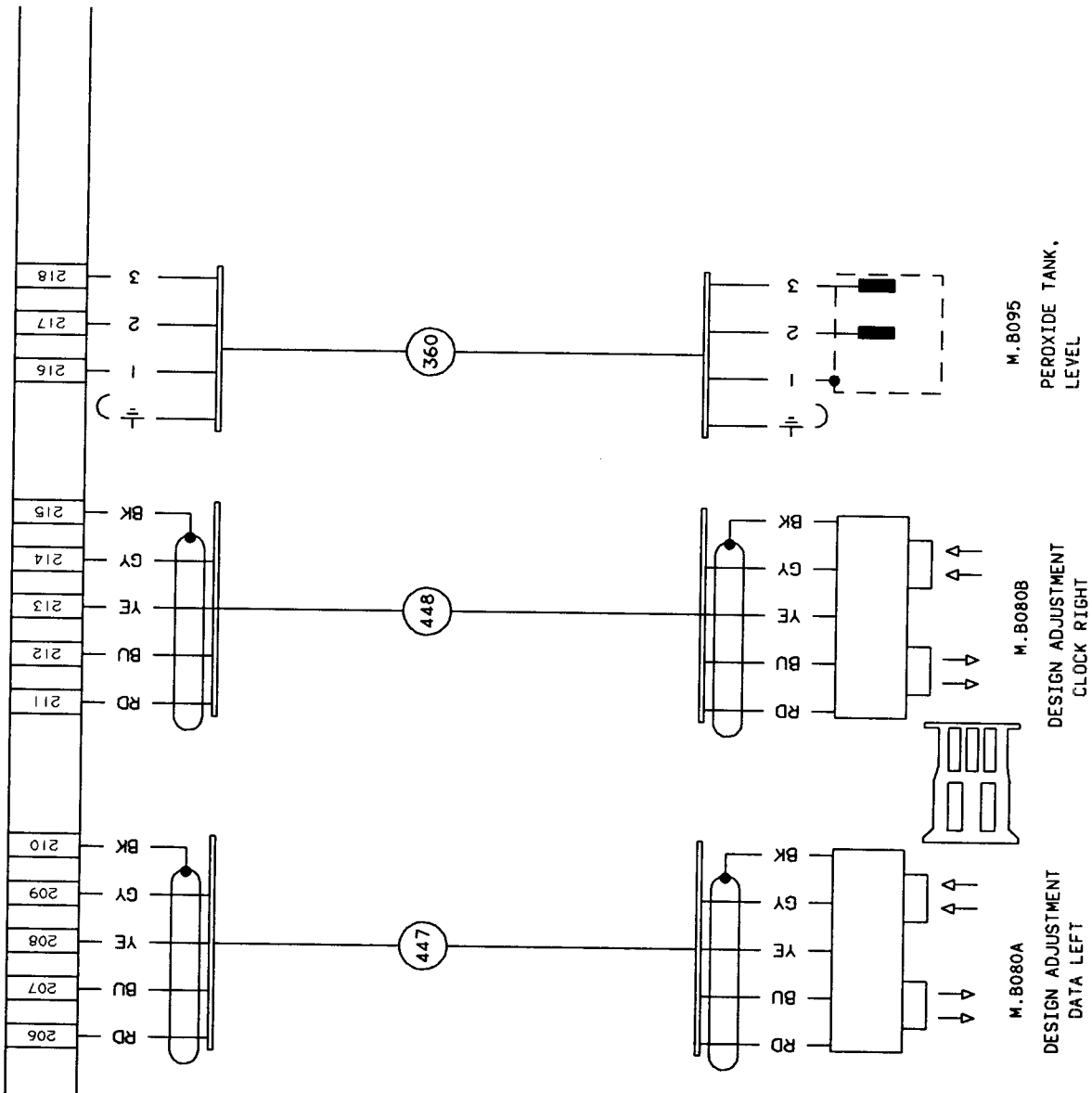

INTRODUCED WITH AM NO.	19260	DATE.	930310	STEP.	HK/JUTH
TITLE					
AM NO.					
DATE					
STEP.					
ALTERATIONS ONLY IN CADAM					
				DESCRIPTION:	CONNECTION DIAGRAM
				MACHINE:	TBA/9-1401 S.A
					61232-20:01

This drawing must not without the consent of Tetra Pak be copied, transmitted or disclosed to any third party.

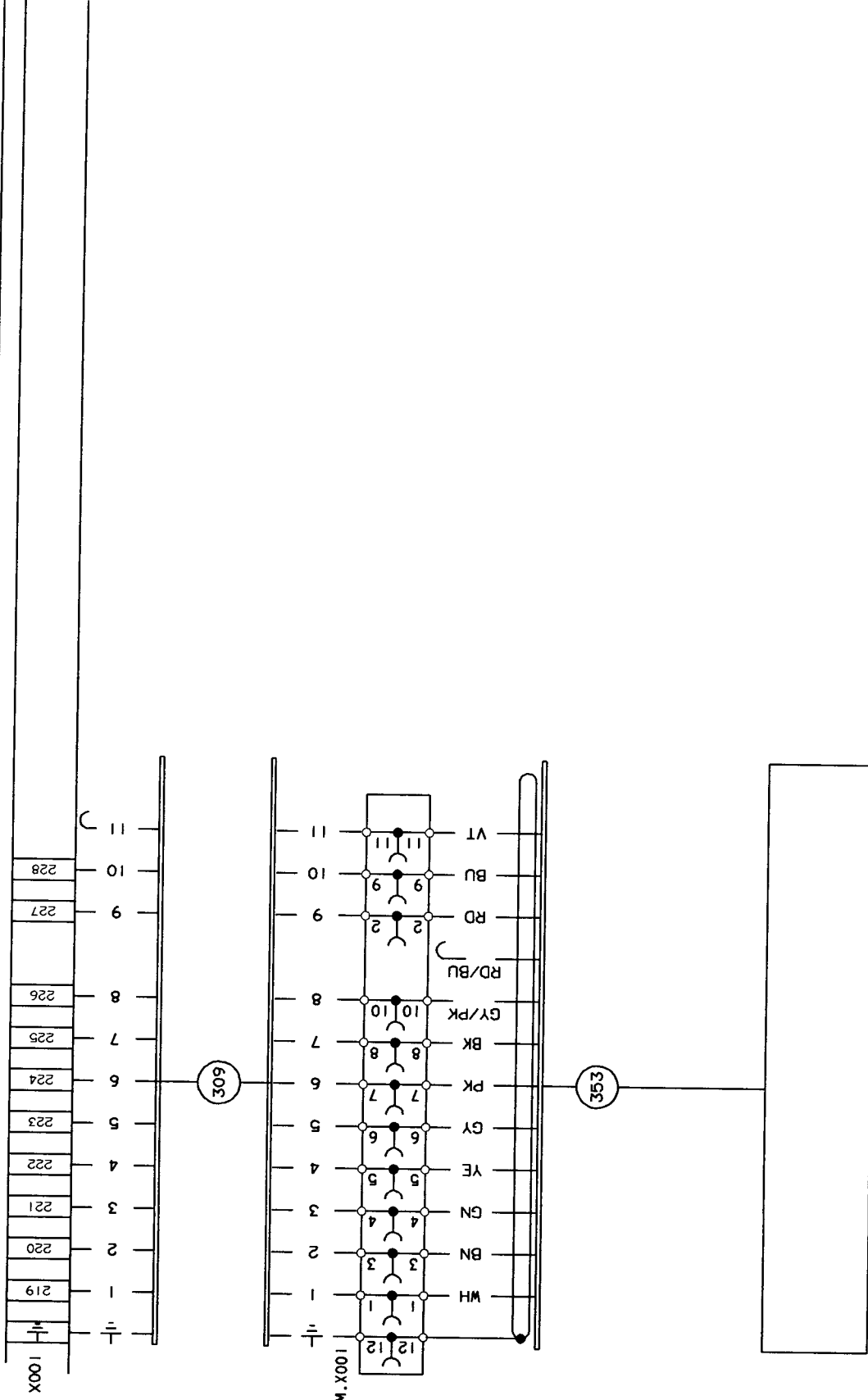

M.B001  
MAIN MACHINE, ANGEL ENCODER

INTRODUCED WITH AM NO. 19260		DATE: 930310	REV: HK/UTH	FOOT NOTE: CABLE CORES ARE TO BE MARKED WITH TERMINAL DESIGNATION	
TABLE				DESCRIPTION:	CONNECTION DIAGRAM
AM NO.				MACHINE:	TBA/9-1401 S.A
DATE					
REV.					61232-21:01
ALTERATIONS ONLY IN CADAM					
DRAWING REMARKS					

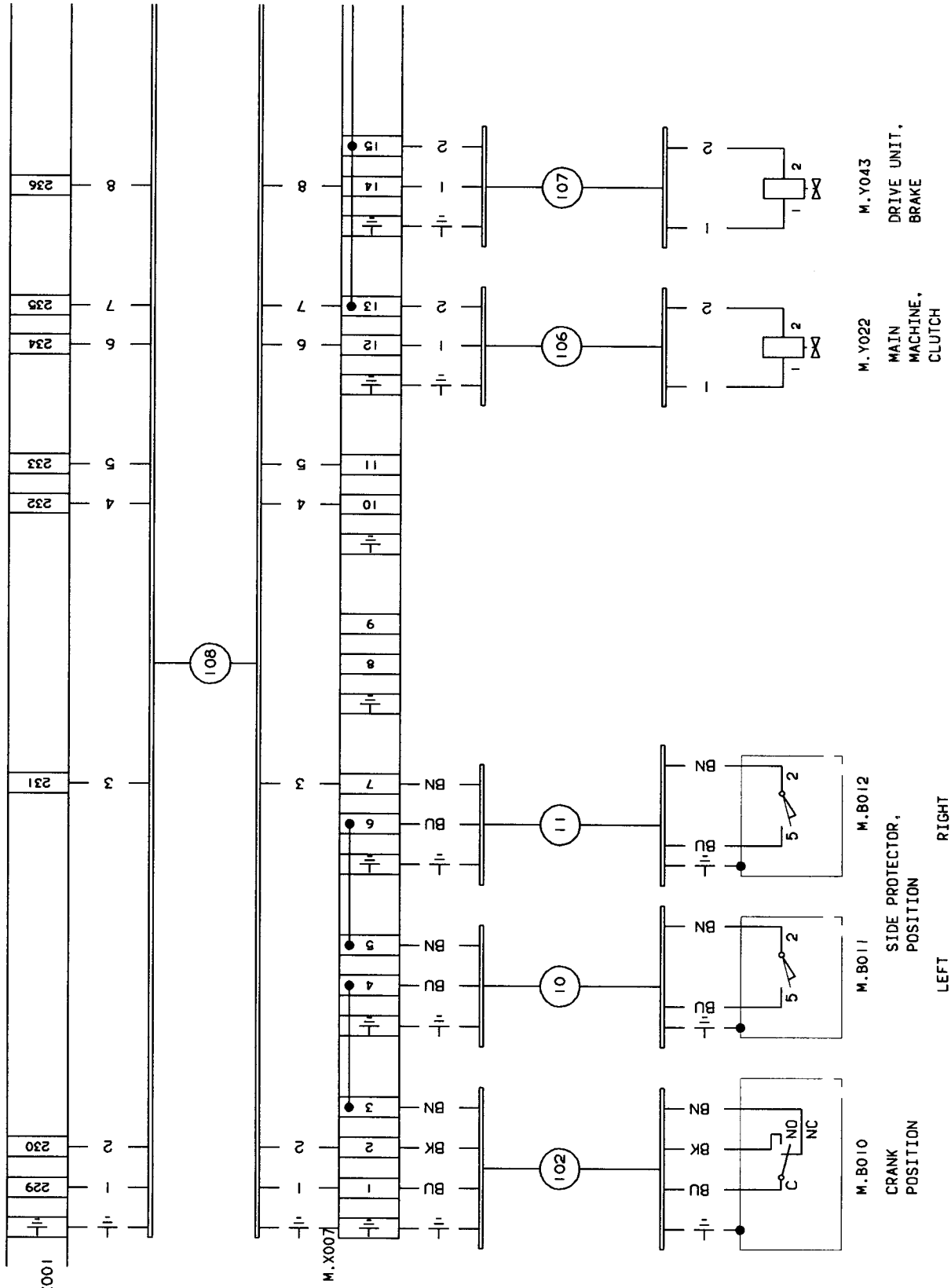

INTRODUCED WITH AM. NO.	19260	DATE	930310	BY	HK/UHTH
ISSUE	A	AM. NO.	20080		
DATE	930909				
BY	HK/MRI				
ALTERATIONS ONLY IN CADAM					
DESCRIPTION:				CONNECTION DIAGRAM	
MACHINE:				TBA/9-1401 S.A	
				61232-22:01	



This drawing must not without the consent of Tetra Pak, be copied, transmitted or disclosed to any third party.

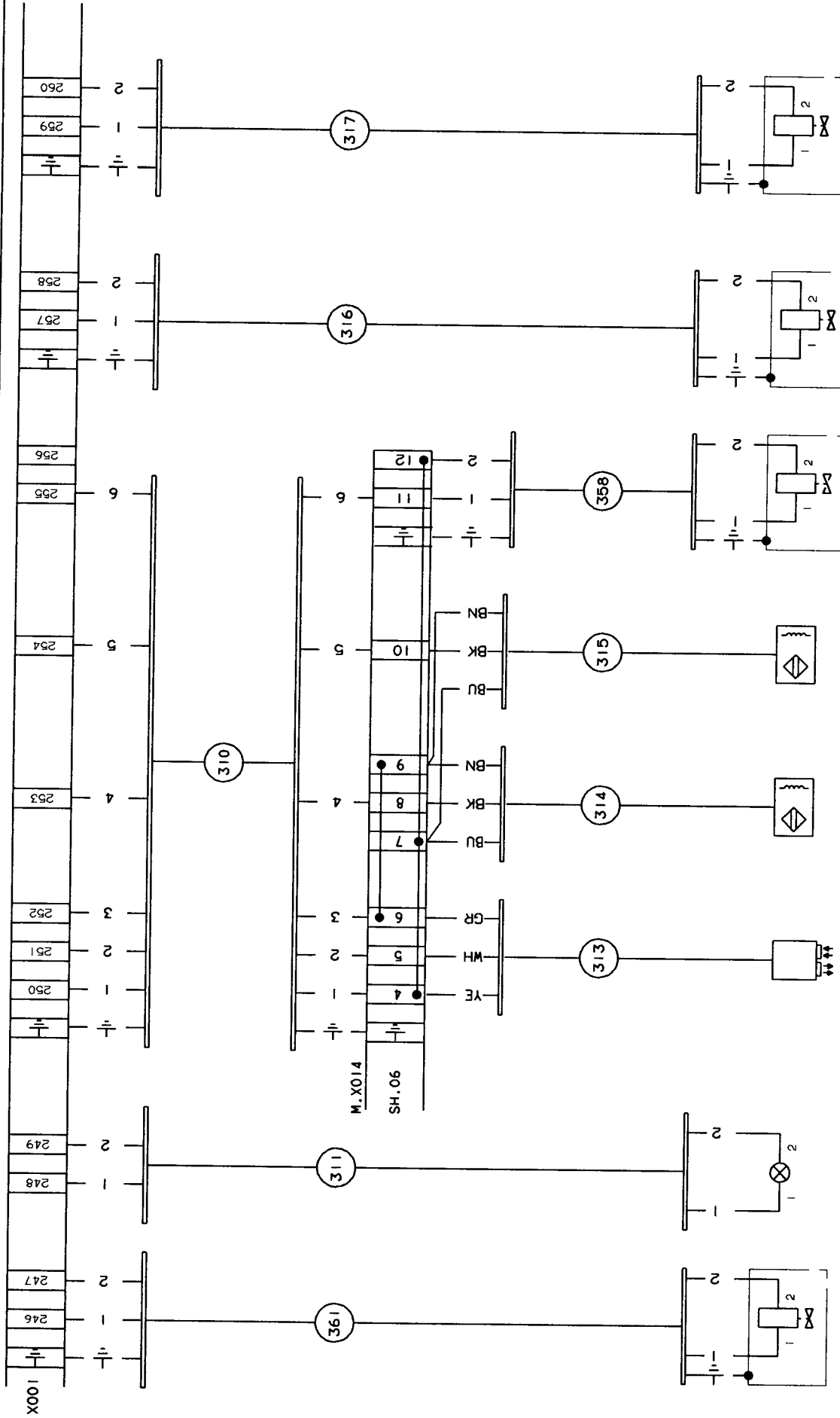

- M.Y092 PEROXIDE TANK FILLING
- M.E011 SPLICER, PAPER
- M.B008 PAPER SUPPLY
- M.B024 UNREELING MOTOR, START
- M.B025 UNREELING MOTOR, STOP
- M.Y063 BRAKE, UNREELING PAPER SUPPLY
- M.Y041 PULL DOWN DEVICE
- M.Y042 PRESSURE DEVICE

INTRODUCED WITH AM NO.	19260	DATE	930310	REV.	HK/UTH
TABLE					
AM NO.					
DATE					
SIGN.					
ALTERNATIONS ONLY IN CADAM					
DESCRIPTION: CONNECTION DIAGRAM					
MACHINE: TBA/9-140I S.A					
61232-24:01					

This drawing must not without the consent of Tetra Pak be copied, transmitted or disclosed to any third party.

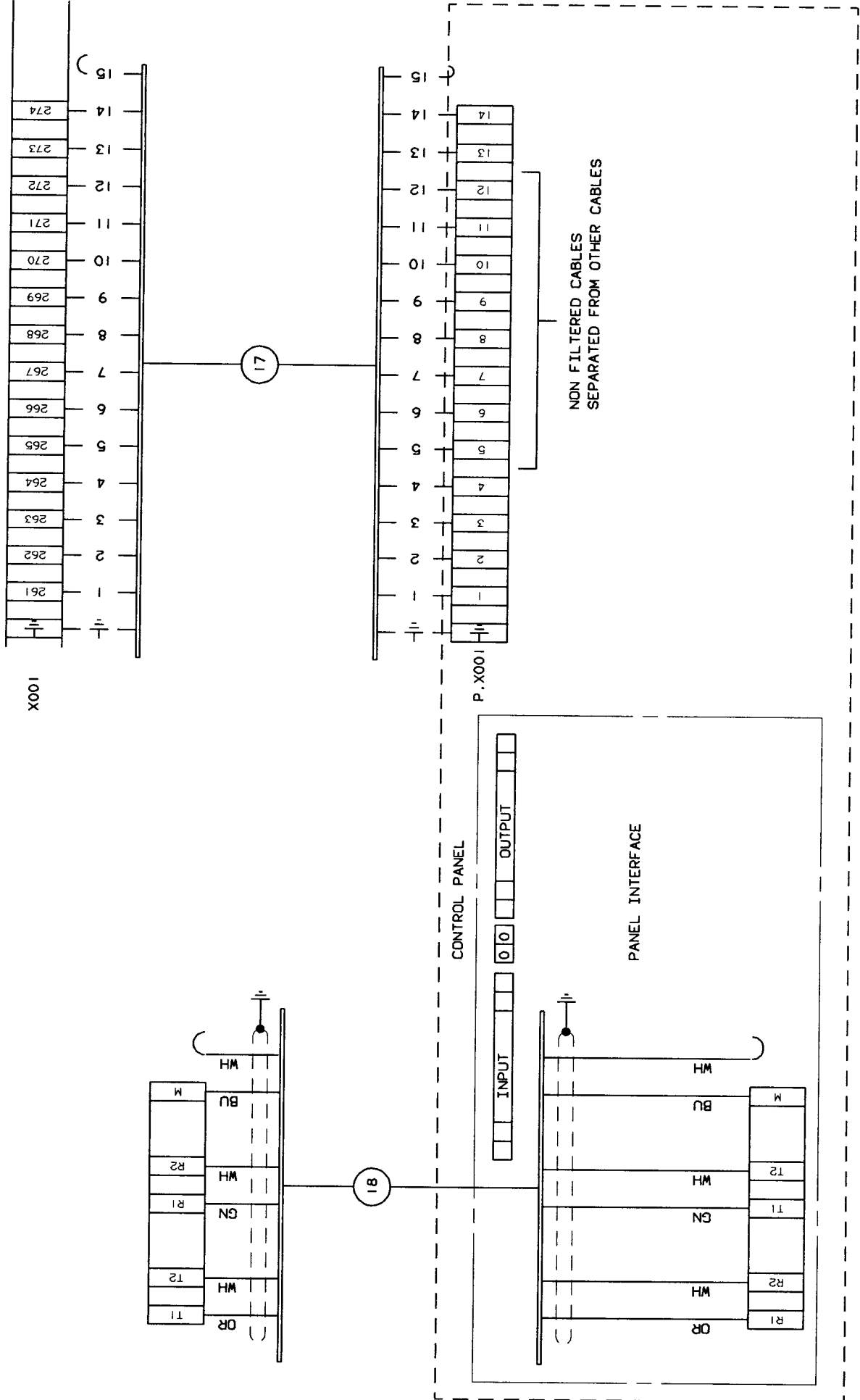

INTENDED BY: AM NO.	DATE: 19260	DATE: 930310	SIGN: HK/ZUTH	DESCRIPTION: CONNECTION DIAGRAM	MACHINE: TBA/9-140I S.A	61232-25:01
DRAWING REVISIONS						
ALTERATIONS ONLY IN CADAM						

X001

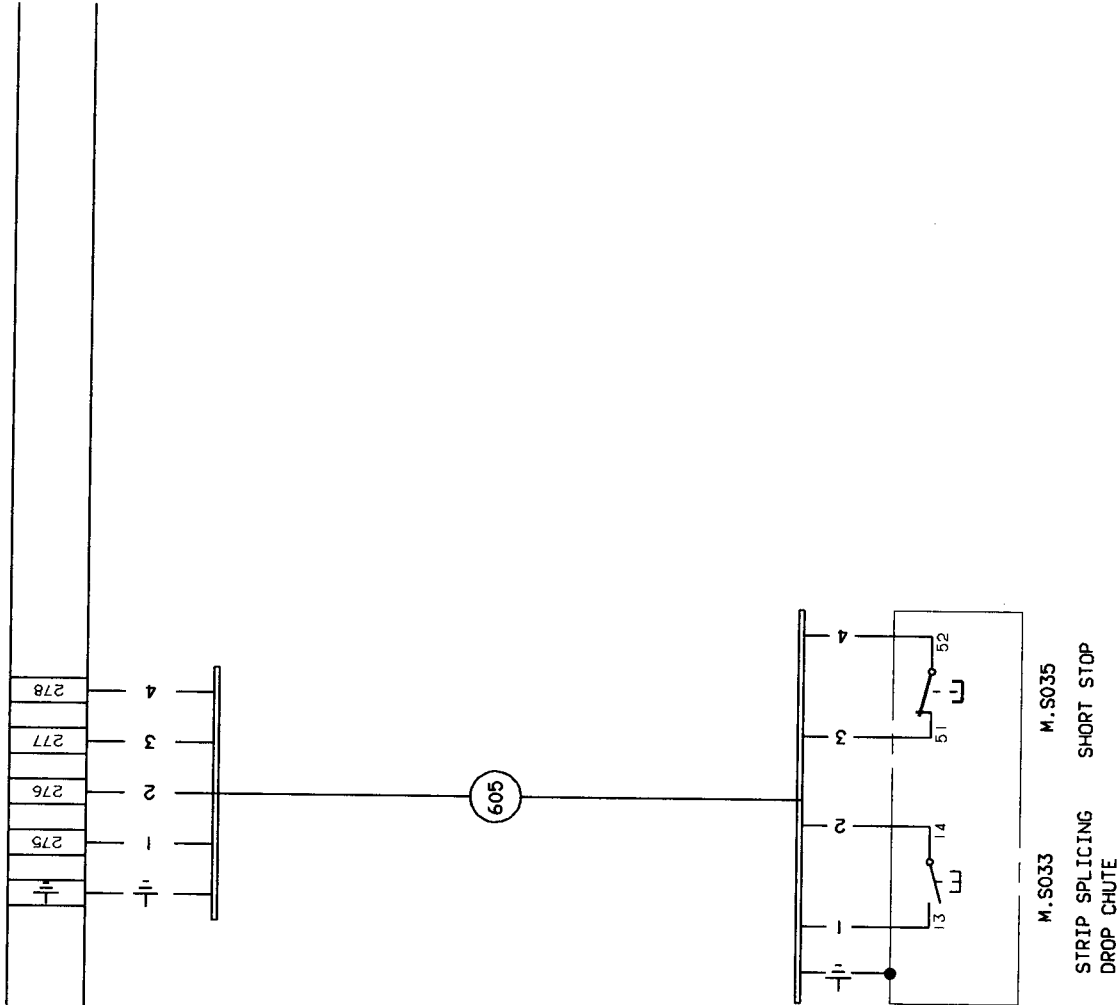

M.S033 STRIP SPLICING DROP CHUTE  
M.S035 SHORT STOP

INTRODUCED WITH AM NO.	19260	DATE	930310	BY	HK/UTH
ISSUE					
AM NO.					
DATE					
BY					
ALTERATIONS ONLY IN CADAM					
DESCRIPTION:				CONNECTION DIAGRAM	
MACHINE:				TBA/9-1401 S.A	
				61232-27:01	

This drawing must not without the consent of Tetra Pak be copied, transmitted or disclosed to any third party.

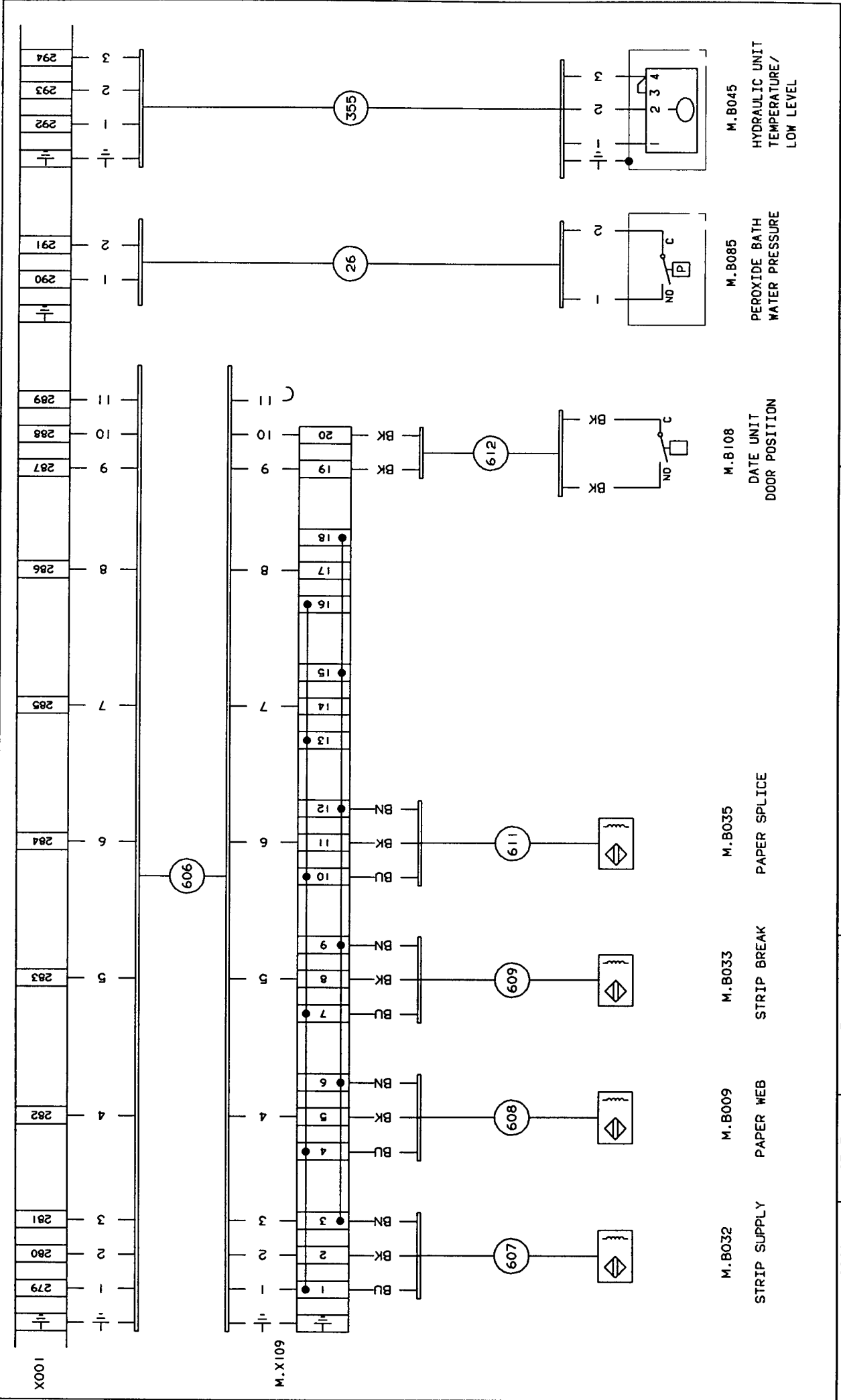

INTRODUCED WITH: AM. NO.		DATE:		REV.		DESCRIPTION:	
TABLE	A	930310		HK/UTH		CONNECTION DIAGRAM	
AM. NO.	20080					MACHINE: TBA/9-1401 S.A	
DATE	930909					61232-28:01	
SIZE:	HK/MRI					DRAWING REMARKS	

**Tetra Pak**  
LUND SWEDEN

This drawing must not without the consent of Tetra Pak, be copied, transmitted or disclosed to any third party.

X001
1
295
296
297
298
299
300
301
302
303
304
305
306
307

INTRODUCED BY: AM. NO.	DATE:	930310	SIGN.	HK/UTH	DESCRIPTION:	CONNECTION DIAGRAM
DRAWING NO.	DATE				MACHINE:	TBA/9-1401 S.A
EDIN.						61232-29:01
ALTERATIONS ONLY IN CADAM						
DRAWING REMARKS						

**Tetra Pak**  
LUND SWEDEN

This drawing must not without the consent of Tetra Pak, be copied, transmitted or disclosed to any third party.

X001	308	309	310	311	312	313	314	315	316	317	318	319	320
------	-----	-----	-----	-----	-----	-----	-----	-----	-----	-----	-----	-----	-----

INTRODUCED BY: AM NO.	19260	DATE:	930310	REV.	HK/UTH	DESCRIPTION:	CONNECTION DIAGRAM
TITLE							
AM NO.							
DATE							
BY:							
ALTERATIONS ONLY IN CADAM						MACHINE:	TBA/9-140  S.A
							61232-30:01

DRAWING REMARKS





**Tetra Pak**  
LUND SWEDEN

This drawing must not without the consent of Tetra Pak, be copied, transmitted or disclosed to any third party.

X001	
	347
	348
	349
	350
	351
	352
	353
	354
	355
	356
	357

INTRODUCED WITH AM NO.	19260	DATE	930310	BY	HK/JTH
TITLE					
AM NO					
DATE					
BY					
ALTERNATIONS ONLY IN CADAM					
DRAWING REMARKS					
DESCRIPTION: CONNECTION DIAGRAM					
MACHINE: TBA/9-1401 S.A					
61232-33:01					







This drawing must not without the consent of Tetra Pak, be copied, transmitted or disclosed to any third party.

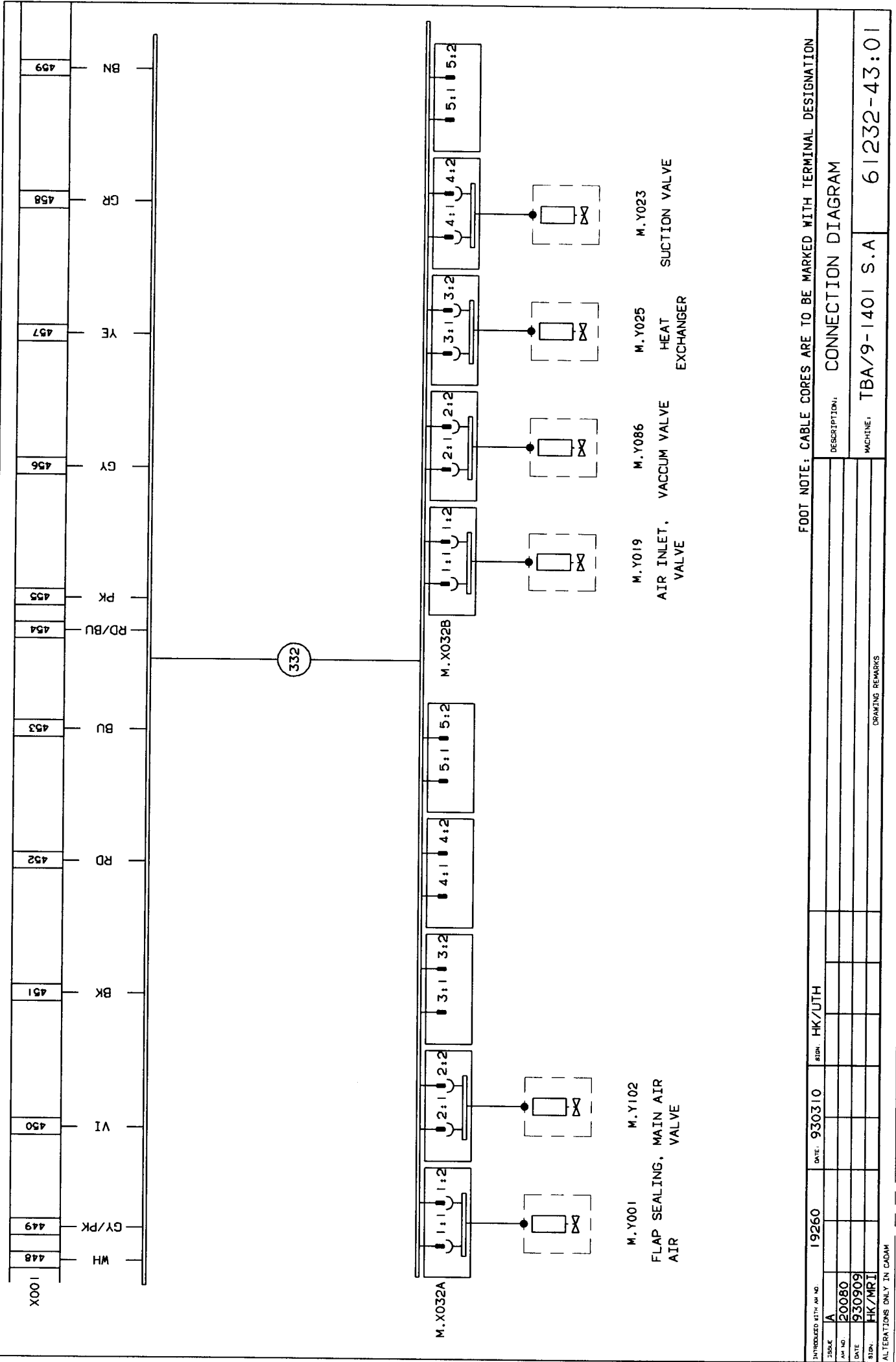

FOOT NOTE: CABLE CORES ARE TO BE MARKED WITH TERMINAL DESIGNATION

INTRODUCTION BY AM. NO.	19260	DATE:	930310	BY:	HK/UTH
ISSUE	A				
AM. NO.	20080				
DATE	930909				
BY:	HK/MRI				
DESCRIPTION: CONNECTION DIAGRAM					
MACHINE: TBA/9-1401 S.A					
DRAWING REVISIONS					
61232-43:01					

ALTERATIONS ONLY IN CADAM

This drawing must not without the consent of Tetra Pak be copied, transmitted or disclosed to any third party.

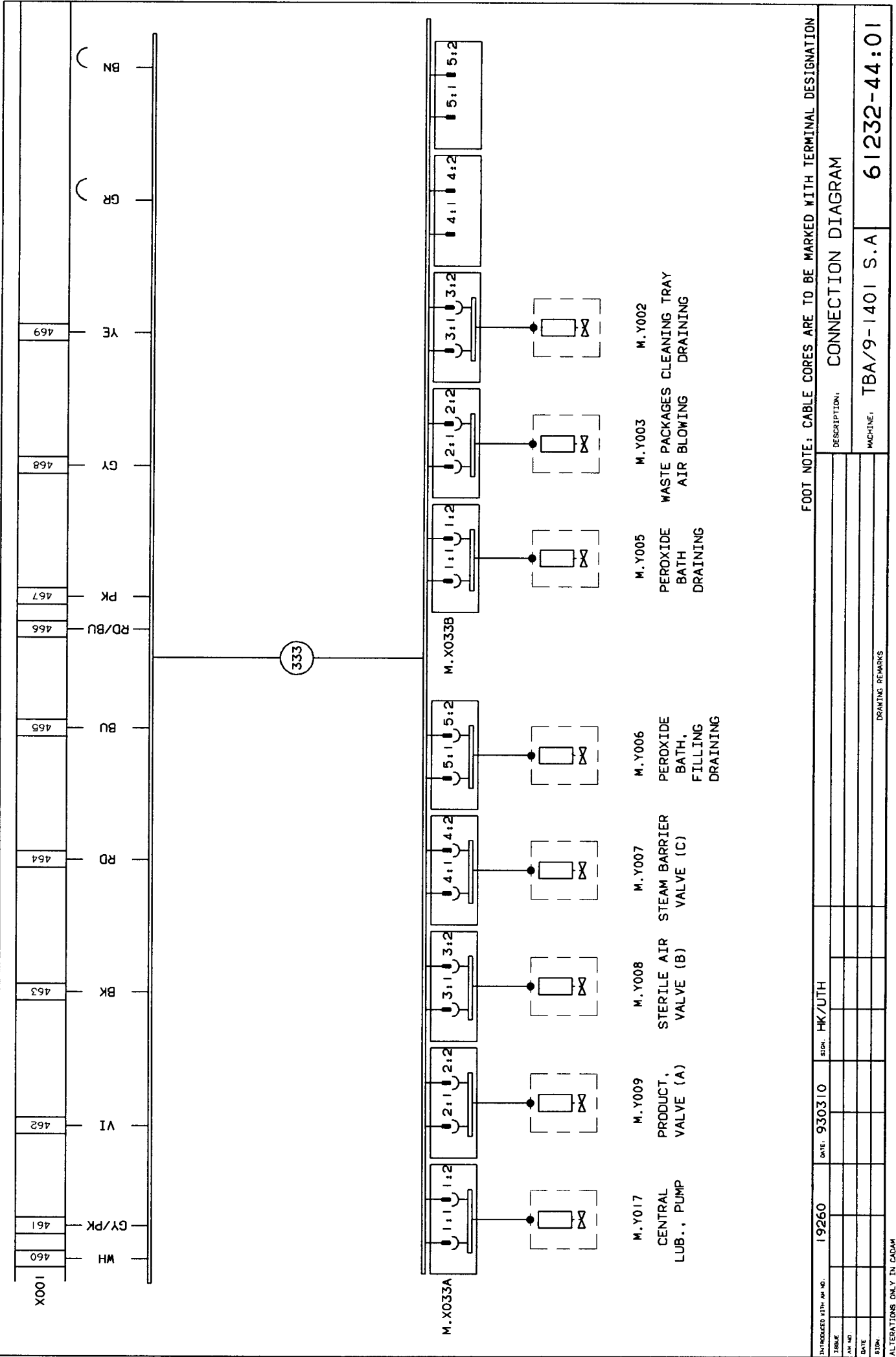

FOOT NOTE: CABLE CORES ARE TO BE MARKED WITH TERMINAL DESIGNATION

INTRODUCED WITH AN NO.	DATE	930310	SIGN.	HK/UTH	DESCRIPTION	MACHINE
	19260				CONNECTION DIAGRAM	TBA/9-1401 S.A
ALTERATIONS ONLY IN CADAM						

61232-44:01

This drawing must not, without the consent of Tetra Pak, be copied, transmitted or disclosed to any third party.

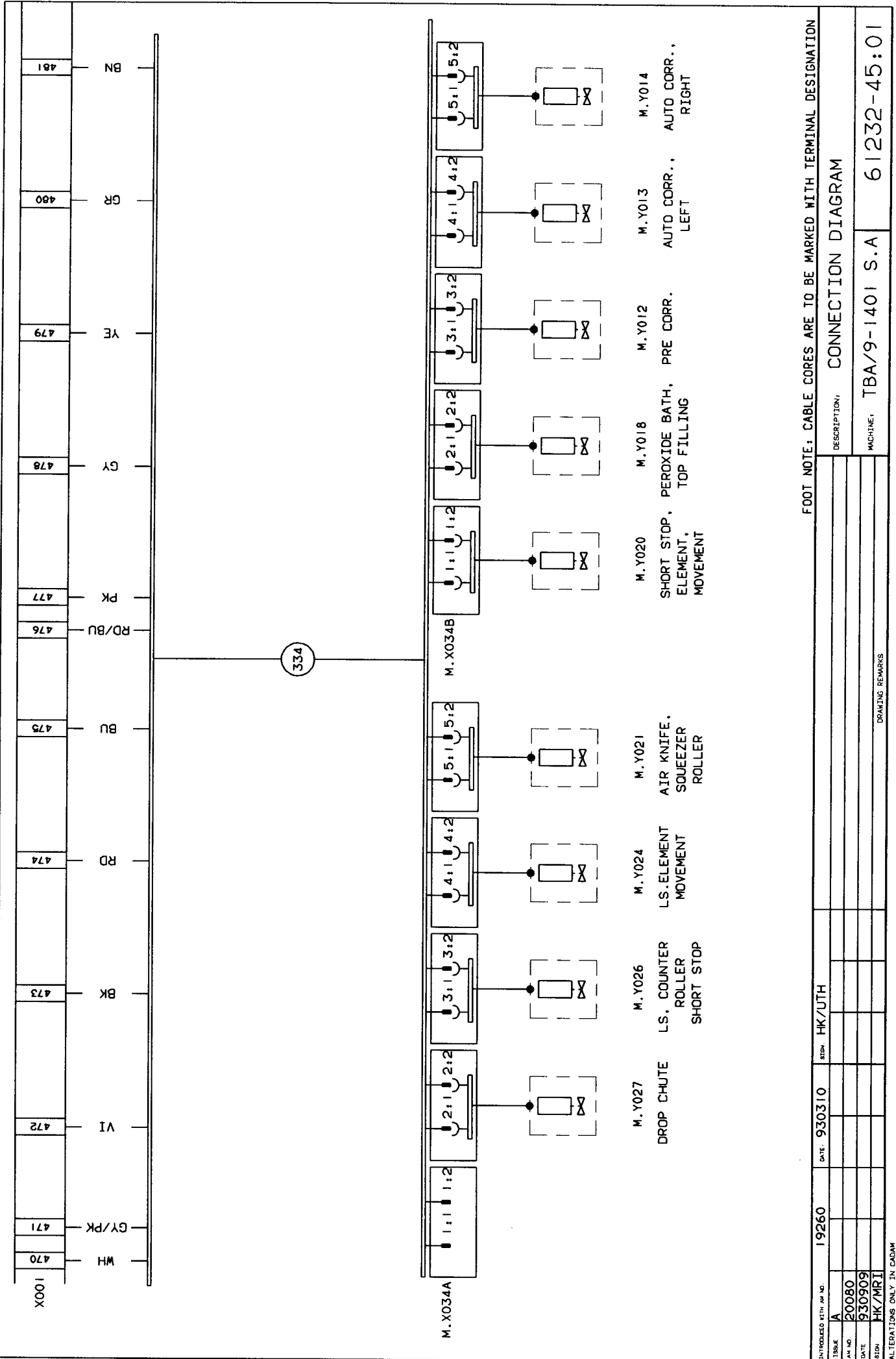

FOOT NOTE: CABLE CORES ARE TO BE MARKED WITH TERMINAL DESIGNATION

INTRODUCED WITH AM NO.	19260	DATE	930310	STDA.	HK/ZUTH
ISSUE	A				
AM NO.	20080				
DATE	930909				
STDA.	HK/MRI				
ALTERATIONS ONLY IN CADAM					
DESCRIPTION:			CONNECTION DIAGRAM		
MACHINE:			TBA/9-1401 S.A		
			61232-45:01		

This drawing must not without the consent of Tetra Pak be copied, transmitted or disclosed to any third party.

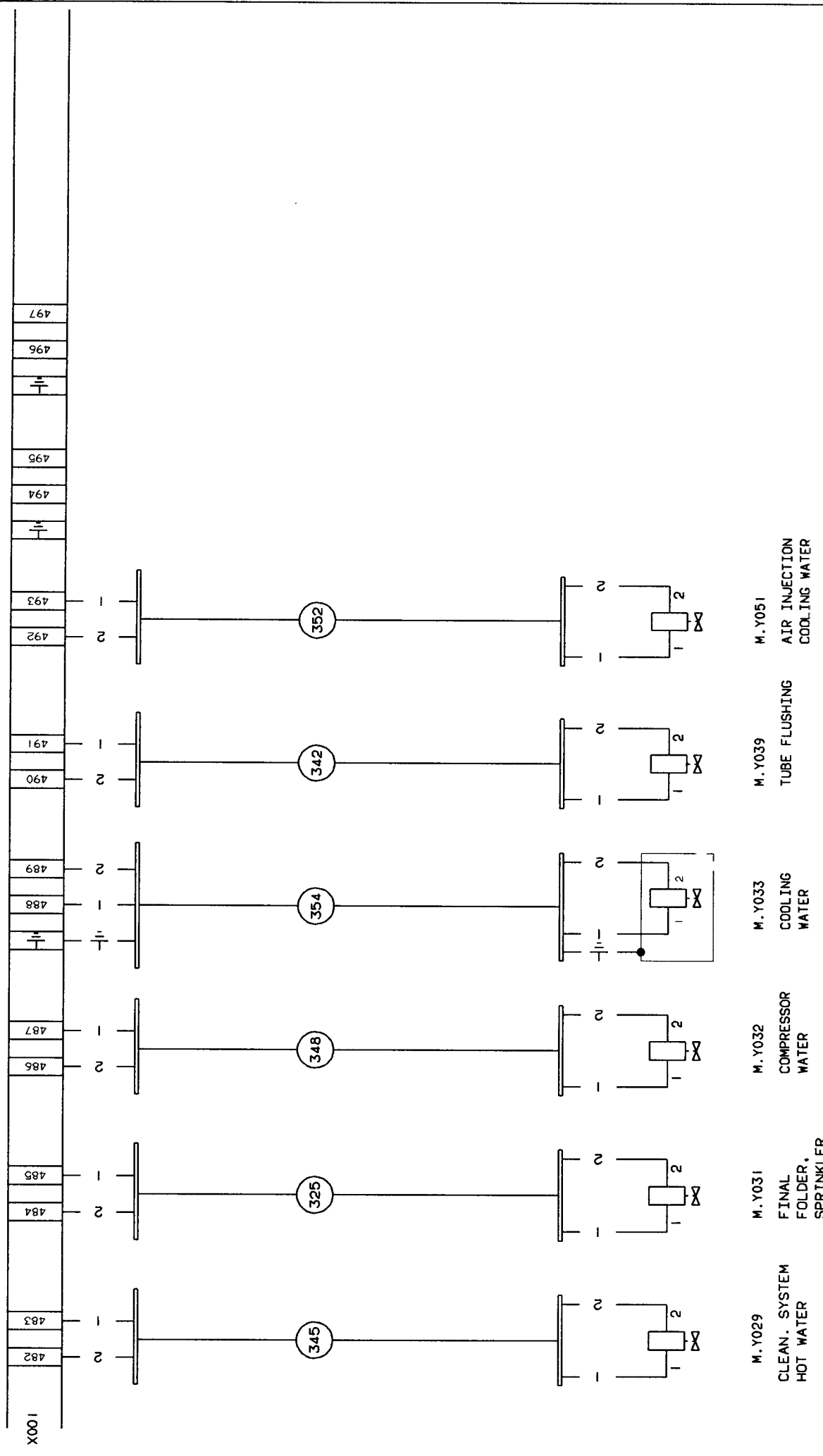

FOOT NOTE: CABLE CORES ARE TO BE MARKED WITH TERMINAL DESIGNATION

INTRODUCED WITH AM NO.	19260	DATE	930310	EDIN.	HK/LUTH
DRWG. NO.					
DATE					
EDIN.					
ALTERATIONS ONLY IN C/004H					

DESCRIPTION: CONNECTION DIAGRAM

MACHINE: TBA/9-1401 S.A

DRAWING NUMBER: 61232-46:01



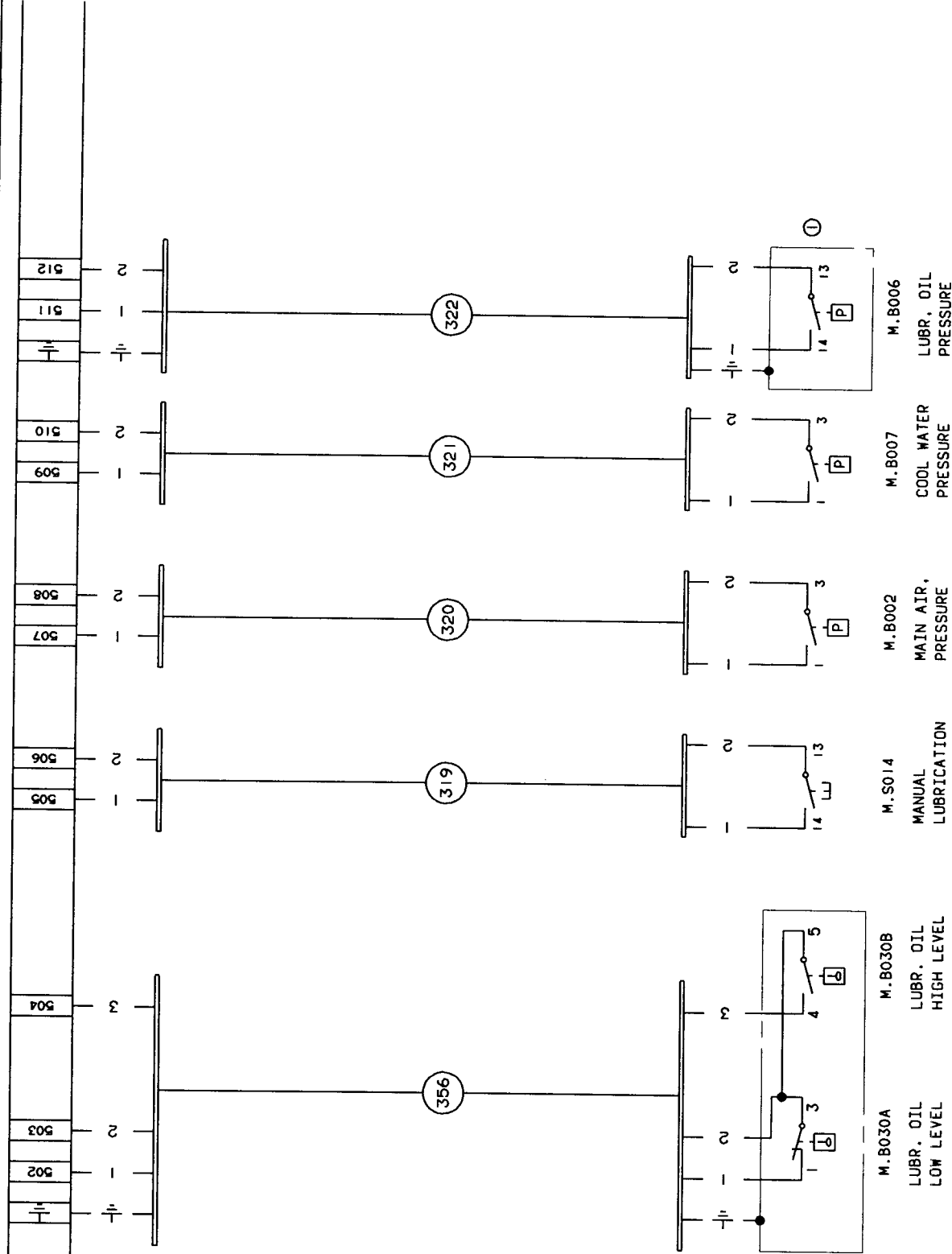

INTRODUCED WITH AM NO.	19260	DATE	930310	REP.	HK/UTH	DESCRIPTION:	CONNECTION DIAGRAM	
TITLE	A	REV.	B	① BEFORE T-ORDER T-13147 AND T-20163 THE CONNECTION IS 1 AND 3 INSTEAD OF 13 AND 14				
AM NO.	20080	20406						
DATE	930909	931015						
REP.	HK/MRI	HK/MRI						
ALTERATIONS ONLY IN CADAM							MACHINE:	TBA/9-1401 S.A
								61232-48:01

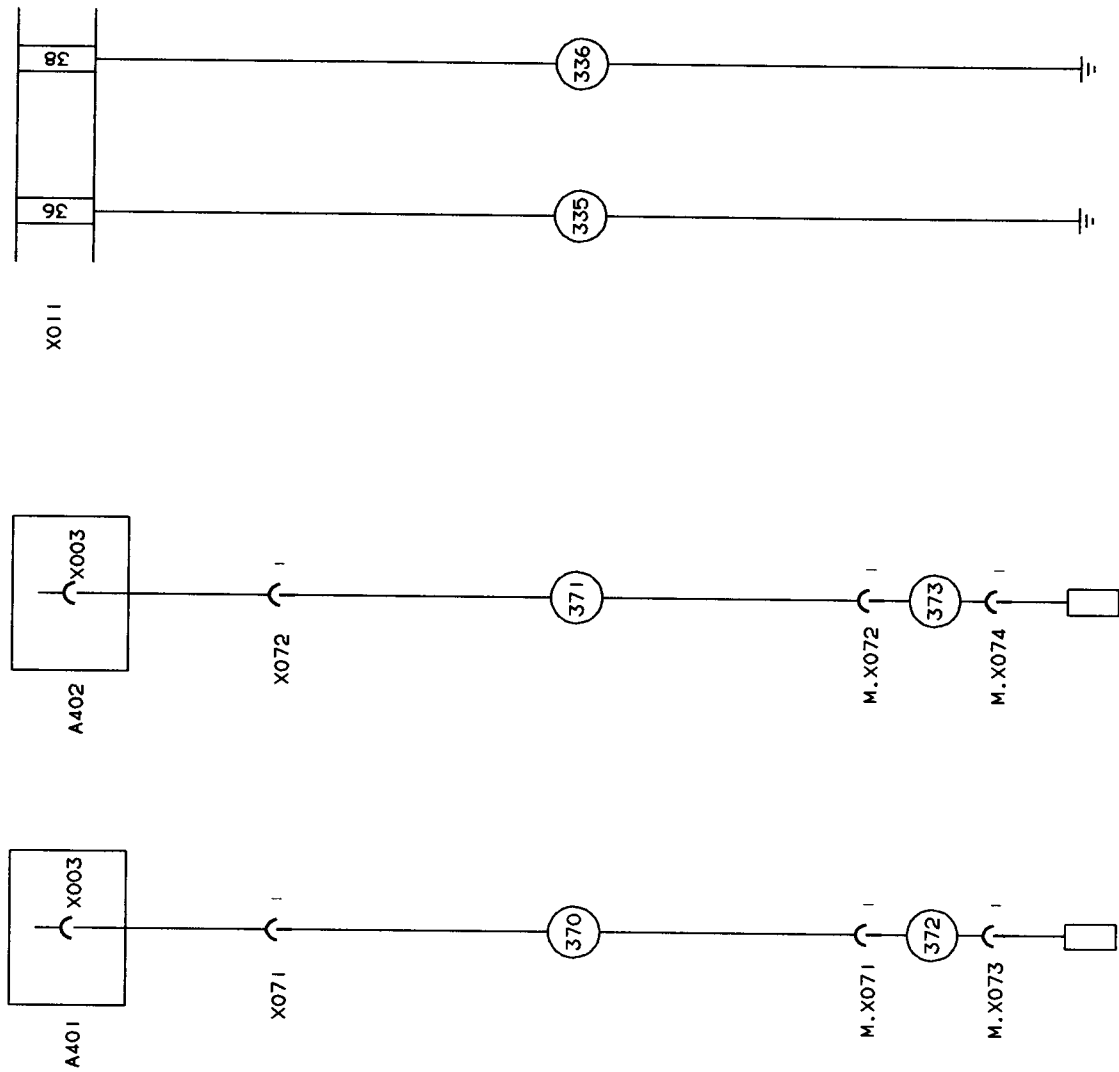

M.L.001  
INDUCTOR  
TS-LEFT

M.L.002  
INDUCTOR  
TS-RIGHT

GROUND  
CONNECTION  
STAND

GROUND  
CONNECTION  
VALVE PLATE

INTRODUCED BY, AM NO.	DATE	BY	CHK/UTH	DESCRIPTION
19260	930310			CONNECTION DIAGRAM
ALTERATIONS ONLY IN CADAM				MACHINE: TBA/9-1401 S.A
				61232-49:01

This drawing must not without the consent of Tetra Pak, be copied, transmitted or disclosed to any third party.

MAIN VOLTAGE 200-600V EXCEPT 400/230V

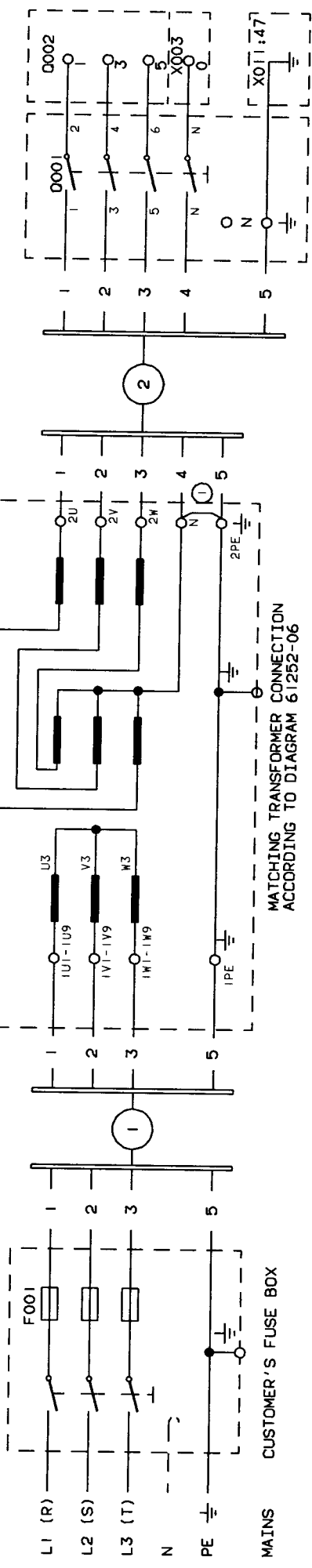

FILLING MACHINE CONNECTION  
ACCORDING TO DIAGRAM "MAINS"

MAIN VOLTAGE 400/230V  
AREA TO CABLE 4x25/16 AND  
SETTING VALUE OF 0002 63/400

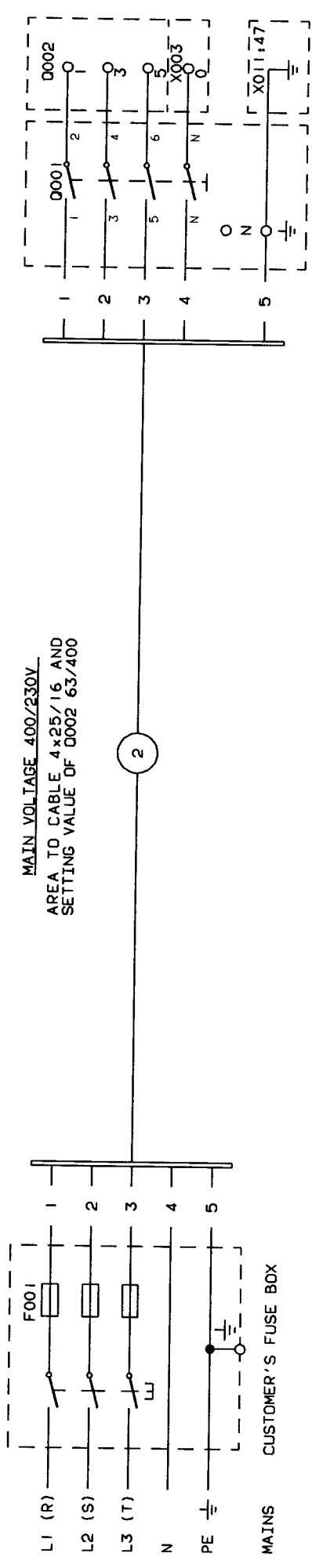

INTRODUCED WITH AM. NO.	19260	DATE	930310	REP.	HK/LUTH
TITLE					
AM. NO.					
DATE					
REP.					
ATTENTION: PROTECTIVE GROUNDING TO BE CARRIED OUT ACCORDING TO CURRENT LOCAL REGULATIONS (O) MAKE SURE THAT THE BRIDGE IS CONNECTED. AREA 16mm <sup>2</sup>					
DESCRIPTION: MAINS CONNECTION					
MACHINE: TBA/9-1401 S.A					
DRAWING REMARKS					
ALTERATIONS ONLY IN CADAM					
61252-05:01					

This drawing must not without the consent of Tetra Pak, be copied, transmitted or disclosed to any third party.

MAIN VOLTAGE V	FUSES (SLOW) ① F001	AREA TO CU CABLES NO.		SETTING VALUE D002	CONNECTIONS ON MATCHING TRANSFORMER		
		A	B		MAINS	TAP	CONNECT
600/347 3x600	100	3x16/16	4x25/16	63/400	PHASE L1 PHASE L2 PHASE L3 N GROUND PE	U9 U9 U9 N N	U3 - U4 U3 - U4 U3 - U4
550/318 3x550	100	3x16/16	4x25/16	63/400	PHASE L1 PHASE L2 PHASE L3 N GROUND PE	U8 U8 U8 N N	U3 - U4 U3 - U4 U3 - U4
500/289 3x500	125	3x25/16	4x25/16	63/400	PHASE L1 PHASE L2 PHASE L3 N GROUND PE	U7 U7 U7 N N	U3 - U4 U3 - U4 U3 - U4
480/277 3x480	125	3x25/16	4x25/16	63/400	PHASE L1 PHASE L2 PHASE L3 N GROUND PE	U6 U6 U6 N N	U3 - U4 U3 - U4 U3 - U4
440/254 3x440	125	3x25/16	4x25/16	63/400	PHASE L1 PHASE L2 PHASE L3 N GROUND PE	U5 U5 U5 N N	U2 - U4 U2 - U4 U2 - U4
415/240 3x415	125	3x25/16	4x25/16	63/400	PHASE L1 PHASE L2 PHASE L3 N GROUND PE	U5 U5 U5 N N	U1 - U4 U1 - U4 U1 - U4
3x400 [3x380]	160	3x25/16	4x25/16	63/400	PHASE L1 PHASE L2 PHASE L3 N GROUND PE	U4 U4 U4 N N	U1 - U4 U1 - U4 U1 - U4
240/140 3x240	250	3x70/35	4x25/16	63/400	PHASE L1 PHASE L2 PHASE L3 N GROUND PE	U3 U3 U3 N N	U3 - U4 U3 - U4 U3 - U4
220/127 3x220	250	3x70/35	4x25/16	63/400	PHASE L1 PHASE L2 PHASE L3 N GROUND PE	U2 U2 U2 N N	U3 - U4 U3 - U4 U3 - U4
200/115 3x200	315	3x95/50	4x25/16	63/400	PHASE L1 PHASE L2 PHASE L3 N GROUND PE	U1 U1 U1 N N	U3 - U4 U3 - U4 U3 - U4

MATCHING TRANSFORMER  
90245-0024

Y/Z II-WIRED

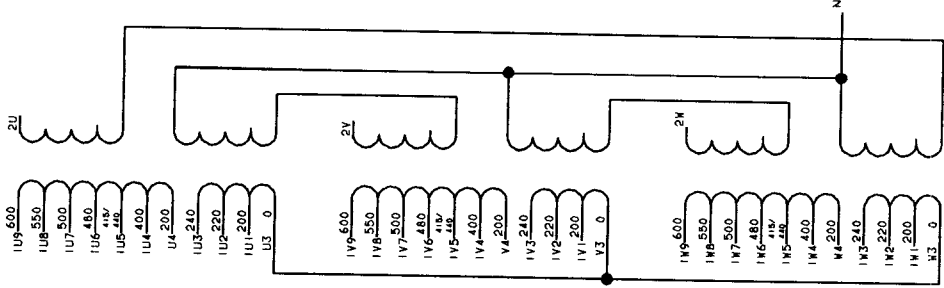

RECOMMENDED MAINS FUSE TO ACHIEVE SELECTIVITY

MATCHING TRANSFORMER

TBA/9-1401 S.A. MACHINE 61252-06:01

ALTERATIONS ONLY IN CADAM

This drawing must not, without the consent of Tetra Pak, be copied, transmitted or disclosed to any third party.

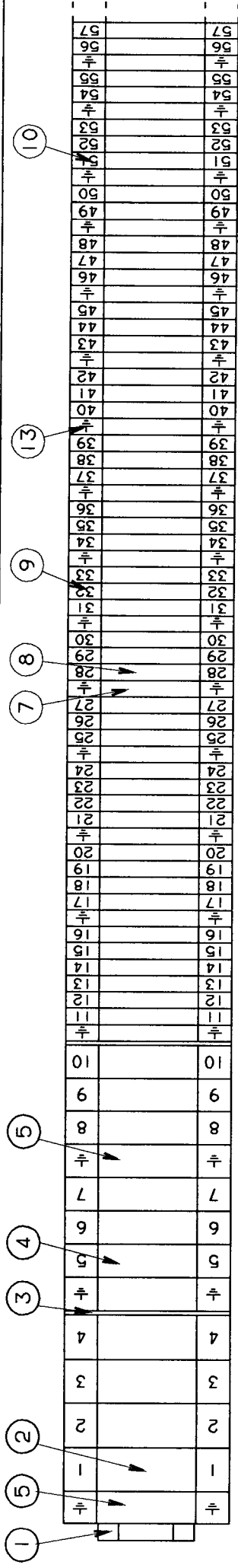

X001

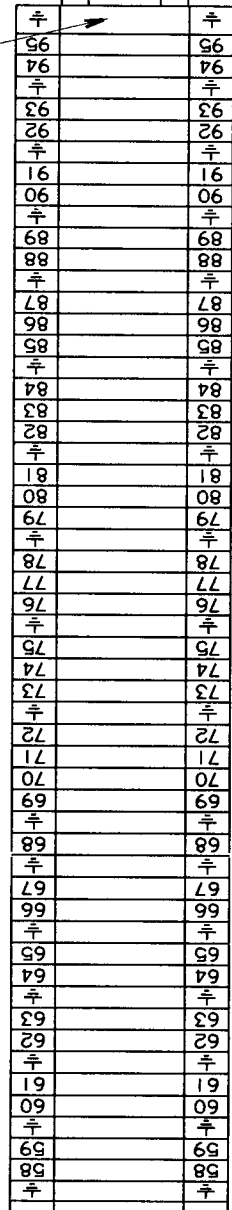

X001

PDS.	TYPE	COMP. NO.	QUANT.	
:1	TS35 STEEL	3834.0	90077-302 L=1050mm	1
:2	WDU 35	10205.0	353021-219	4
:3	WAP	10501.0	353032-006	2
:4	WDU 16	10204.0	353021-218	6
:5	WPE 16	10104.0	353024-208	14
:6	WPE 6	10102.0	353024-206	1
:7	WPE 4	10101.0	353024-205	43
:8	WDU 4	10201.0	353021-213	85
:9	FW 1-50	4734.6	359011-807	3
:10	FW 51-100	4734.6	359011-808	2
:11	TS35 STEEL	3834.0	90077-302 L=280mm	1
:12	WPE 35	10105.0	353024-209	2
:13	GW	5762.6	359011-202	2

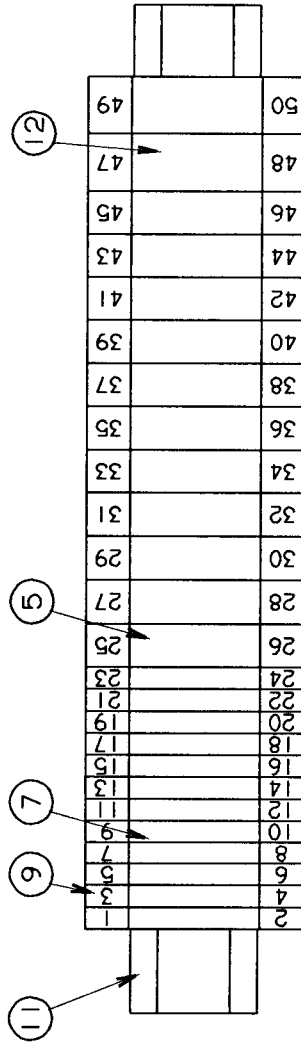

X001

INTRODUCED WITH AM. NO.	17786	DATE:	930115	BY:	HK/LJTH
TABLE					
AM. NO.					
DATE					
BY:					
DRAWING REMARKS					
DESCRIPTION: TERMINAL BLOCK X001, X011					
MACHINE: TBA/9-1401 S.A					
570926-0001					

This drawing must not without the consent of Tetra Pak, be copied, transmitted or disclosed to any third party.

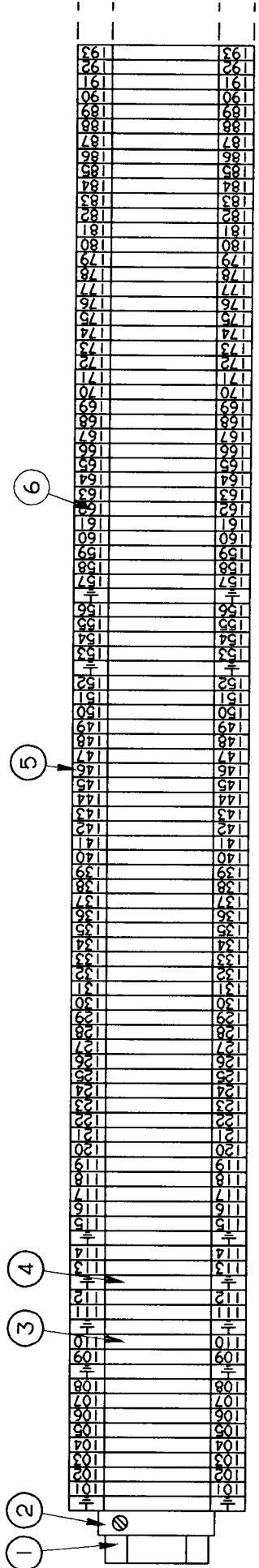

X001

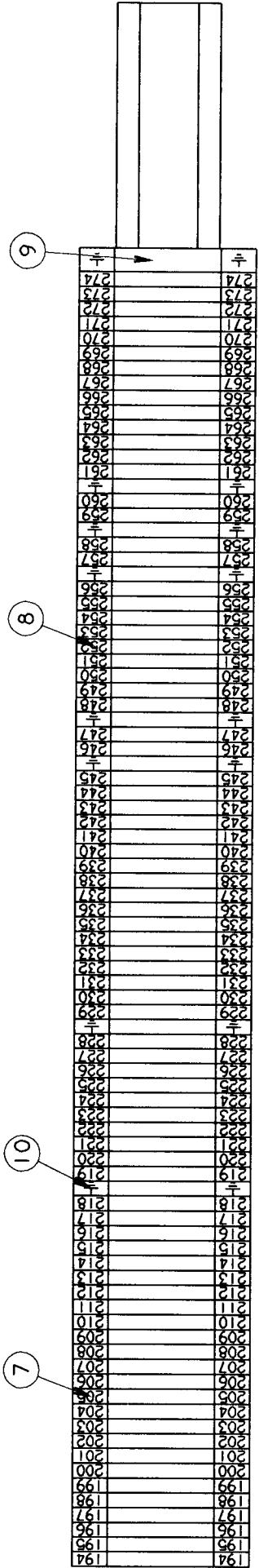

X001

POS.	TYPE	COMP. NO.	QUANT.
:1	TS35 STEEL	90077-302 L=1050mm	1
:2	EW 35	353031-201	1
:3	WDU 2.5	353021-216	174
:4	WPE 2.5	353024-204	14
:5	FW 101-150	359011-809	2
:6	FW 151-200	359011-810	2
:7	FW 201-250	359011-811	2
:8	FW 251-300	359011-812	2
:9	WPE 6	10102.0 353024-206	1
:10	GW	5762.6 359011-202	1

INTRODUCED WITH AM NO.	17786	DATE	930115	SIGN.	HK/JUTH
ISSUE					
AM NO.					
DATE					
SIGN.					
ALTERATIONS ONLY IN CADAM					
DRAWING REMARKS					
DESCRIPTION: TERMINAL BLOCK X001					
MACHINE: TBA/9-1401 S.A 570926-0002					

This drawing must not without the consent of Tetra Pak be copied, transmitted or disclosed to any third party.

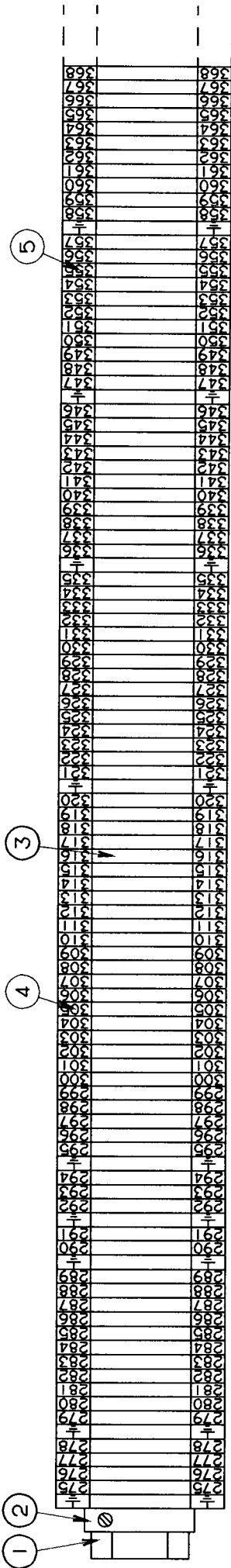

X001

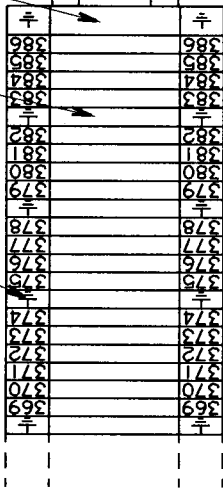

PDS.	TYPE	COMP. NO.	QUANT.
:1	TS35 STEEL	90077-302 L=1060mm	1
:2	EW 35	353031-201	1
:3	WDU 2,5	10200.8	112
:4	FW 301-350	4734.6	2
:5	FW 351-400	4734.6	2
:6	WPE 2,5	10100.0	14
:7	WPE 6	10102.0	1
:8	GW	5762.6	1

INTRODUCED WITH AM. NO.	17786	DATE	930115	REVN.	HK/JUH
ISSUE					
AM. NO.					
DATE					
REVN.					
ALTERATIONS ONLY IN CADAM					
DESCRIPTION:			TERMINAL BLOCK X001		
MACHINE:			TBA/9-1401 S.A		
			570926-0003		
DRAWING REMARKS					

This drawing must not be copied, reproduced, transmitted or disseminated in any form or by any means without the consent of Tetra Pak, to whom all requests to reproduce this drawing should be addressed.

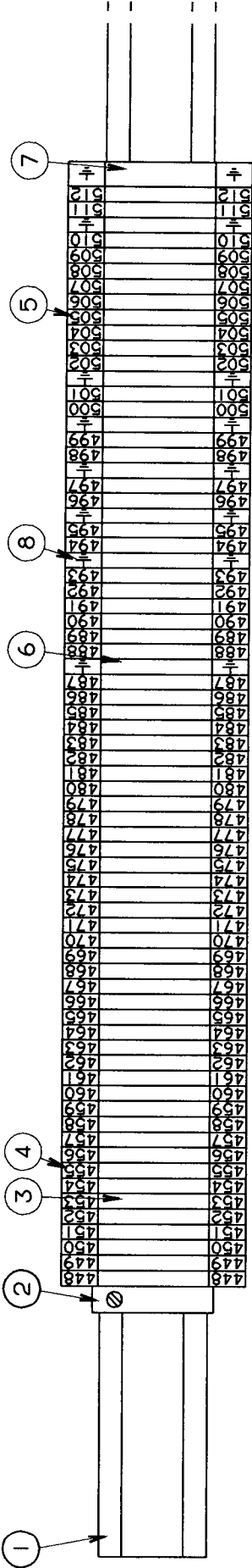

X001

POS.	TYPE	COMP. NO.	QUANT.
:1	TS35 STEEL	90077-302 L=1050mm	1
:2	EW 35	353031-201	1
:3	WDU 2.5	353021-216	65
:4	FW 450-500	359011-816	2
:5	FW 501-550	359011-817	2
:6	WPE 2.5	353024-204	7
:7	WPE 6	353024-206	1
:8	GM	5762.6 359011-202	1

ALTERATIONS ONLY IN CADAM

INTRODUCED WITH AM. NO.	17786	DATE:	930115	SIGN:	HK/JUTH
TABLE:	A				
AM. NO.	20080				
DATE:	930909				
SIGN:	HK/MRI				
DESCRIPTION: TERMINAL BLOCK X001					
MACHINE: TBA/9-1401 S.A					
DRAWING REMARKS: 570926-0004					

571517

**OVERLOAD PROTECTIONS**

POS.	SETTING	FUNCTION
0003	50Hz-25A/40°C 60Hz-25A/40°C	MAIN POWER
0012	50Hz-2, 0A/40°C 60Hz-2, 0A/40°C	CONTROL TRANSFORMER
0051	50Hz-7, 0A/40°C 60Hz-6, 0A/40°C	MAIN MOTOR, LOW SPEED
0077	50Hz-10A/40°C 60Hz-10A/40°C	MAIN MOTOR HIGH SPEED
0081	50Hz-2, 9A/40°C 60Hz-2, 9A/40°C	HYDRAULIC PUMP

POS.	SETTING	FUNCTION
0082	50Hz-1, 5A/40°C 60Hz-1, 5A/40°C	PEROXIDE PUMP
0087	50Hz-9, 2A/40°C 60Hz-9, 4A/40°C	COMPRESSOR, INLET
0091	50Hz-6, 8A/40°C 60Hz-8, 0A/40°C	CLEANING SYSTEM, CIRCULATION PUMP
0093	50Hz-1, 2A/40°C 60Hz-1, 3A/40°C	EXTERNAL CONVEYOR
0094	50Hz-0, 45A/40°C 60Hz-0, 45A/40°C	PAPER SUPPLY

POS.	SETTING	FUNCTION
0098	50Hz-9, 2A/40°C 60Hz-9, 4A/40°C	COMPRESSOR SUCTION
0099	50Hz-0, 94A/40°C 60Hz-0, 94A/40°C	PEROXIDE BATH, WATER PUMP
0201	50Hz-1, 3A/40°C 60Hz-1, 3A/40°C	SA, SHORT STOP, FAN

**FUSE PANEL**

POS.	FUNCTION
F001	TIME RECORDER, WALL SOCKET FAN MOTOR, SPLICER-LIGHT FIXTURES
F005	FLAP SEALING TOP/BOTTOM
F008	LS, SHORT STOP
F010	LONGITUDINAL SEALING
F017	DETERGENT PUMP, BENDING ROLLER
F019	CONTROL VOLTAGE, 220V AC TPMC, UNITS
F028	PEROXIDE BATH, WATER

POS.	SIZE	FUNCTION
F029	25A	AIR SUPER HEATER
F030	10A	PAPER SUPPLY, UNREELING
F031	10A	PAPER SUPPLY, UNREELING
F041	80A	FLAP SEALING, TOP
F042	80A	FLAP SEALING, BOTTOM
F055	10A	CONTROL VOLTAGE, 24V DC
F056	10A	TPIH

POS.	FUNCTION
F202	16A STRIP APPLICATOR

F055C	
F055B	
F055A	
F017	
S	
F019	
S	
F005	
F008	
F001	

F010	
F028A	
F028B	
F028C	
F029A	
F029B	
F029C	
F030	
F031	
F056A	
F056B	
F056C	
F202	

F041	
F042	

**MAX LOAD CIRCUIT BREAKER**

POS.	SETTING	MAGNETIC SETTING	FUNCTION
0002	63A/55°C	400A/55°C	WINS, EL CABINET

TBA/9-1401 S.A.

INTRODUCED WITH AM NO.	17786	DATE:	930115	SIGN.	HK/JTH
FIGURE	A	B	C	D	
AM NO.	19260	20080	20398	20513	
DATE	930310	930427	931001	940427	
SIGN.	HK/JTH	HK/PSB	HK/MR.J	HK/MR.J	

FUSE PANEL LABEL

TBA/9-1401 S.A.

571517

This drawing must not without the consent of Tetra Pak be copied, transmitted or disclosed to any third party.

LUND SWEDEN

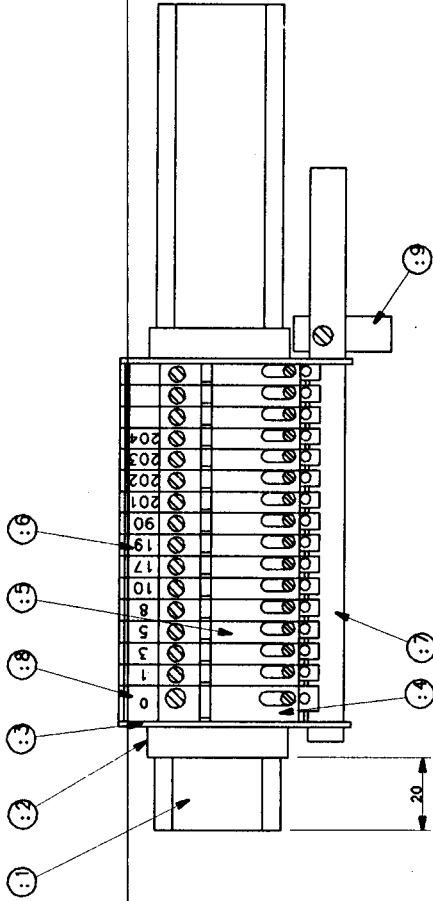

POS	TYPE	COMP. NO.	QUANT
:1	TS35 STEEL	3834.0 80077-302 L=230	1
:2	EW 35	3835.6 353031-201	2
:3	WHP	10502.8 353033-104	2
:4	WNT 10	10109.8 353022-004	1
:5	WNT 6	10108.8 353022-003	15
:6	FW 1.50	4734.6 359011-807	1
:7	FW 201-250	4734.6 359011-811	1
:8	SSSch 10-3	2598.0 353041-001 L=160	1
:9	GW 0	5227.6 359011-807	1
:9	ZB-35	2665.0 80135-19	1

INTRODUCED WITH REF. NO.	DATE.	SIGN.	DESCRIPTION:
DATE	17786	930115	TRV/0711
SIGN.			
ALTERNATIONS ONLY IN CAD/JAM			TERMINAL BLOCK X3
			TBA/9-140V
			571518



This drawing must not be copied, reproduced, or disclosed to any third party.

MODENA ITALY

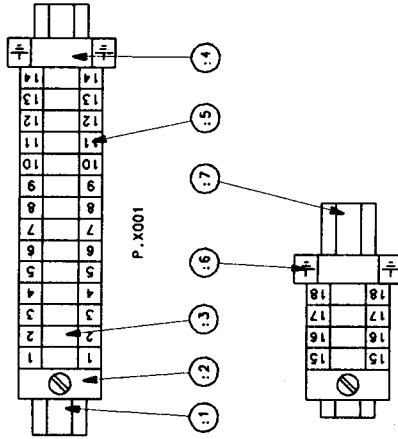

POS	TYPE	COMP. NO.	QUANT
:1	TS15 STEEL	1175.0 90077-328 L=120mm	1
:2	EW15	3828.6 90077-307	2
:3	AWZ 4	2943.6 90077-078	18
:4	AWZ 4	3802.6 90135-126	2
:5	FW 1-50	4735.6 359011-807	2
:6	FW	5762.6 359011-202	1
:7	TS15 STEEL	1175.0 90077-328 L=60mm	1

P.X002

INTRODUZCO WITH AN NO.		DATE:		SIGN:		DESCRIPTION:	
FORME							
AN NO.							
DATE	17750	930115	MM/YY/TH				TERMINAL BLOCK P.X001, P.X002
SIGN.	20080	810809	MM/YY/TH				TBA/9-140V
							571520
ALTERATIONS ONLY IN COLUMN							
DRAWING REMARKS							
MACHINE:							

This drawing must not, without the consent of Tetra Pak, be copied, transmitted or disclosed to any third party.

MODENA ITALY

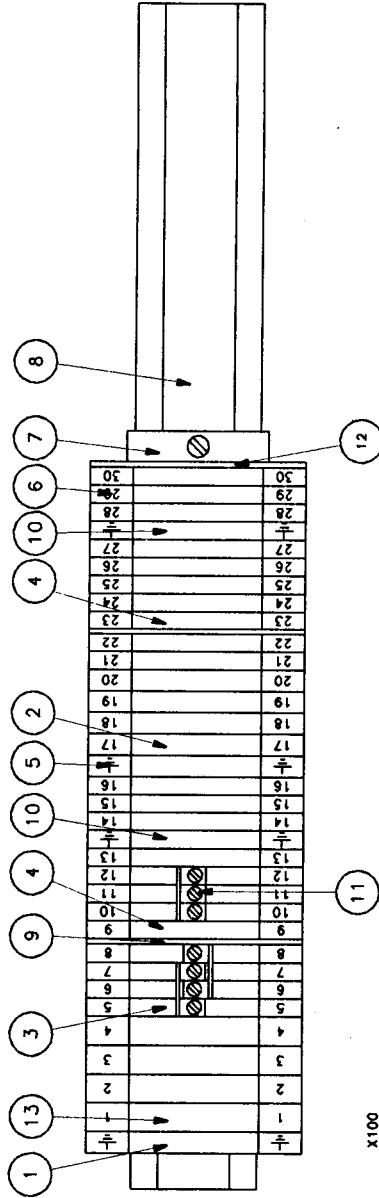

POS	TYPE	COMP. NO.	QUANT
:1	WPE 4	10101.0 353021-228	2
:2	MDU 4	10201.0 353021-213	6
:3	MDU 2,5	10200.0 353021-212	4
:4	MDU 2,5	10200.8 353021-216	16
:5	GW	5762.6 359011-202	1
:6	FW 1-50	4735.6 359011-607	2
:7	FW 35	3835.6 353031-201	1
:8	TSS5 STEEL	3834.0 30077-302 L=350mm	1
:9	WTW 2,5-10	10501.0 353032-006	2
:10	WPE 2,5	10100.0 353024-204	2
:11	WPE 2,5/10	10537.6 353034-030	1
:12	WAP 2,5	10500.8 353032-005	1
:13	MDU 6	10202.0 353021-214	4

INTRODUCED BY: M. NO.	DATE:	DATE:	DATE:	DESCRIPTION:
17788	17788	17788	17788	TERMINAL BLOCK TH, X100
APPROVED BY: M. NO.	DATE:	DATE:	DATE:	
20080	20080	20080	20080	TBA/9-140V
30309	30309	30309	30309	571524
MACHINE:				
DRAWING REMARKS:				
ALTERATIONS ONLY IN CADAM				

This drawing must not, without the consent of Tetra Pak, be copied, transmitted or disclosed to any third party.

MODENA ITALY

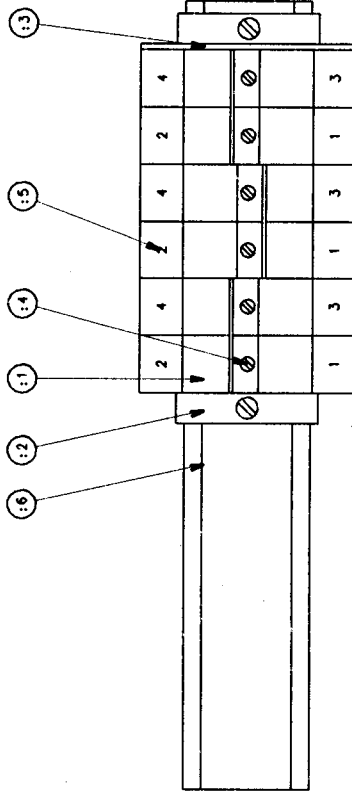

POS	TYPE	COMP. NO.	QUANT
:1	WU 35	10205.0 353021-219	6
:2	EW 35	3835.6 353031-201	2
:3	WAP 16-35	10501.0 353021-245	1
:4	WU 35/10	10530.6 353021-240	3
:5	FW 1-30	4686.6 359011-871	3
:6	FS35 STEEL	3834.0 90077-302 L=220mm	1

INTRODUCED WITH NO.:		DATE:		S. OR.		DESCRIPTION:	
17760	930115	11/07/11					TERMINAL BLOCK XL1, XL2, XL3
14	20080						TBA/9-140V
15	510503						571525
DRAWING REMARKS							MACHINE:
ALTERATIONS ONLY IN CAD/IM							

LIST OF BLOCKS

05 PULSE AND FLASHGENERATING  
06 POSITIONS MACHINELADDER, STEP UP CONDITIONS  
07 PREHEATING 1, PEROXID TANK HANDLING AND PREHEATING 2  
08 TUBESEALING AND PRESTERILIZING  
09 SPRAYING  
10 DRYING, PREHEATING 3  
11 SIGNALS TO AND FROM STERILIZER  
12 STARTSEQUENZER FOR RUNNING PRODUCTION  
13 ROTATION/CONG/FFU/STRIP/JAW/WATER BATH/PAPER SUPPLY/SUCT., AIR-INLET AND B-VALVE  
14 DRIVEMOTOR AND PRODUCTION  
17 TRANSVERSAL SEALING  
18 DESIGN CORRECTION  
19 DUMPING OF PACKAGES  
20 NO PRODUCTION ALLOWED  
23 PRODUCTION ENDED, INTERNAL CLEANING  
24 EXTERNAL CLEANING  
25 LUBRICATION  
26 6-CHANNEL RECORDER  
27 MAINS INTERRUPT AND ALARMDELAYS  
28 JUMP TO MACHINELADDERPOSITION "STERILIZATION FULLFILLED" (POSITION 3)  
29 JUMP TO ZEROPOSITION IN MACHINELADDER  
30 ALARM 1 TO 16 ON ALARMDISPLAY/BEACON  
31 ALARM 17 TO 32 ON ALARMDISPLAY  
32 ALARM 33 TO 48 ON ALARMDISPLAY  
33 ALARM 49 TO 64 ON ALARMDISPLAY  
90  
99 FAST FUNCTIONS, TS, DESIGN PULSE

LIST OF ADDRESSES

TBA/9-1401 S.A.  
47615 200ML

ECN22852

951009 HK/PRI  
940916 HK/MRI  
940426 HK/RAI

Type: 64.1  
Size: 8445  
Blocks: 27  
Rungs: 370  
Addresses: 597

I/O Map:

	RACK	0	1	2	3	4	5	6	7
+	+	+	+	+	+	+	+	+	+
!	!	! I4!	! !O4!	!O0!O4!	! ! ! !	! ! ! !	! ! ! !	! ! ! !	! ! ! !
!	P !	+	+	+	+	+	+	+	+
!	O ! C !E1!I5!	!	!O5!	!O1! !	! ! ! !	! ! ! !	! ! ! !	! ! ! !	! ! ! !
!	W !	+	+	+	+	+	+	+	+
!	E ! U !I2!I6!	!	! !O6!	! ! ! !	! ! ! !	! ! ! !	! ! ! !	! ! ! !	! ! ! !
!	R !	+	+	+	+	+	+	+	+
!	!	!	!	!	!	!	!	!	!
!	!	!	!	!	!	!	!	!	!
+	+	+	+	+	+	+	+	+	+

Fast I/O: Block90  
Block99 E01 I06 O21

Scan time: Block05-89: 10  
Block90-98: 2  
Block99: 1

Sector: 0 = E01 1 = E01 2 = 3 = 4 = 5 = 6 = 7 =

LIST OF ADDRESSES

Address	Position	Function	used in rungs
C000		Printed design photocells	
C001		Monitor position printed	*1805, *1806
C002		Sequencer filling of	*1809, *1810, *1811
C005		Sequencer for spraying of	*2407, *2409
C006		Sequencer for spraying of	*0903, *0904
C007		Sequencer drying after	*0903, *0904
C009		Monitor machine speed	*1003, *1004
C010		Monitor paper low supply	*1438, *1441
C011		Max.time level tank	*1312, *1313
C0000.0	5-	Photocell pulse prod.	*0708, *0710
C0000.2	9-	Photocell pulse prec.	1807
C0001.0	5-	Package out of design	1807
C0001.1	0-	Startvalue des. mon.	1809, 1812, 1903
C0001.2	0-	Out of des. monitor	0621, 1810, 1813
C0002.1	110-	Allowed fillingttime	0614, 3107
C0002.2	100-	Min filling time	2408
C0002.3	0-	Draining time	2416
C0002.4	570-	Max filling time	2411
C0005.0	110-	Spraying finished	2416
C0005.1	1-	Filling spraytank	0903, 0910
C0005.2	11-	Spray count contr.steam	0905
C0005.3	11-	Min empty- ing time	0908, 2311, 2904, 2906
C0005.4	51-	Max empty- ing time	0909
C0005.5	11-	Spray and paus time	0729, 0909
C0006.1	10-	Limit perox filling	1444
C0006.2	11-	Air inlet tower on	0906
C0007.0	1200-	Drytime over	0726, 2903
C0007.1	1080-	Closing of AP-valve(B)	1003, 1005
C0007.2	1080-	Run. time drying	1006, 3206
C0009.0	105-	Pack. count mach. speed	1444
C0009.1	1-	Speed timer running	1439
C0009.2	109-	New speed test	1440
C0010.0	150-	Max.run pac low supply	1441
C0011.0	900-	M.time low level tank	1313, 2004
			0708

LIST OF ADDRESSES

used in rungs

Address	Position	Function	
CO011.1	900- 905	M.time low	level tank
CO011.2	300- 905	Low level	H2O2 tank
D002	0s40	Startdelay	low speed
D003	0s40	Startdelay	high speed
D004	0s20	Signal des.	correction
D005	10s0	Delay mains	to 0-pos.
D006	0s10	Restart	mains
D007	0s70	Start delay	rot.mon.pap
D008	0s70	Paper	
D009	3s0	Alarm delay	
D010	4s0	Delay fill.	
D011	2m00s	Ready	cleantray
D012	3s0	Delay stop	cleaning
D013	5s0	B-valve pos	suct.valve
D016	30s0	Stop	conveyor
D017	7s0	Stop delay	drive motor
D018	0s70	St.delay FF	rot.monitor
D019	3s0	Delay timer	FF rot.mon
D020	15s0	Delay s.vis	lubr.press.
D021	8s0	Delay s.vis	lubr.press.
D022	20s0	Delay alarm	waterpres.
D023	8s0	Delay	TS.seal off
D024	5s0	Delay TS	off
D025	0s70	Start delay	FF rot.mon.
D026	0s618	Delay time	FF rot.mon.
D027	3s0	Stop delay	from pos. 3
D028	3s0	Drivemotor	off-delay
D029	0s40	Delay brake	
D030	59m59s	Max runtime	lubr. fault
D033	5m00s	Delay heat	off FF
D034	10s0	Suctionvalv	house/bath
D035	6s0	Delay super	steam mon.
D036	10s0	Delay super	water press

0707, 2004

3104

1414

1415

1804

2704

2706

1304

1304

1315

2408

0718

1314

1316

1219

1415

1306

1306

2507

2507

2702

1704

1705

1307

1307

0606

1414

1418

2509

1007

0725

1311

1310

LIST OF ADDRESSES

used in rungs

Address	Position	Function
D037	0s50	LS-/SA
D039	3s0	C-valve off
D040	3s0	Delay
D042	6s0	Delay time
D045	0s70	Delay strip
D046	0s70	Start delay
D047	3s0	Delay cong.
D049	25s0	Sprinkler
D051	3s0	Delay perox
D052	2s5	Alarm delay
D053	0s2	Start delay
D055	2m00s	Delay after
D059	5s0	Main air
D060	0s5	Main air
D061	2s0	Alarm delay
D062	2s0	Alarm delay
D065	4s5	Main air
D067	2m00s	Delay alarm
D072	2s0	Check delay
D073	35s	Delay alarm
D090	2m00s	CIP record
D091	2m00s	CIP record
D093	1s0	Delay time
D096	0s50	Delay after
D097	22s00	End prolong
E01		M.M. angle
E01.07		M.M. angle
I02.01	M.B10-15	Safety
I02.02	M.B21A,B,C	Superstruct
I02.03	Q201-Q94	Overload

elements on  
aft.sh.stop  
C-valve on  
for C-valve  
rotat.monit  
str.rot.mon  
monitor  
time  
bath level  
ster.air pr  
ster.air pr  
short stop  
pressure  
check delay  
  
check delay  
  
H2O2 hi.lvl  
on  
off  
Photo cell  
Short Stop  
filling  
  
bit 07  
monitors  
door posit.  
protection

1216  
1430  
1430  
1430  
1308  
1308  
1305  
1433  
1207  
0720  
0609  
0714  
1010  
1010  
0723  
0724  
1010  
3104  
2707  
0712  
2323  
2323  
1220  
1209  
1210  
  
1406  
1406  
  
0621, 1202, 1204, 1309, 1410, 1420, 1803,  
2803, 3307  
0619, 0702, 0703, 1217, 2305, 2306, 2405,  
2904, 3111, 3307  
0516, 0621, 1204, 1309, 1420, 2803, 3308

LIST OF ADDRESSES

Address	Position	Function	used in rungs
I02.04	S34-M.S35	No product.	0516, 2005
I02.05	M.B10	Crank pos.	1410, 1413, 1414, 1415, 1418, 3307
I02.06	M.S33	Strip spl.	1911, 1912
I02.07	S2	Clean throu	2321
I02.10	S4	Service	0604, 0610, 0620, 0621, 0904, 0910, 1005, 1006, 1012, 1102, 1103, 1106, 1107, 1206, 2004, 2008, 2304, 2309, 2311, 2602, 2603, 2903, 2904, 2905, 2906, 3014, 3306
I02.11	M.S14	Manual	0509
I02.12	M.B2	Main air	0509, 0608, 0619, 0706, 0717, 1010, 2305
I02.13	M.B7	Cool water	0620, 2702, 3303
I02.14	M.B6	Lubr.oil	2507, 2508
I02.15	M.B30:A	Lubr oil	0509, 0516, 0619, 2403, 2404, 2509, 3302
I03.00	M.B8	Paper	1312, 1313, 3102
I03.01	M.B24	Unreeling	1420
I03.02	M.B25	Unreeling	1420, 1421
I03.03	M.S4,S32,	Emergency	0706, 2707, 2708, 3308, 3309
I03.04	M.B44	Infeed	0510, 1423
I03.05	M.B9	Paper web	0507, 1905
I03.06	M.B32	Strip	3015
I03.07	M.B33	Strip	0508
I03.10	M.B35	Paper	0511
I03.11	M.B46-47	Air knife/	2003, 2603, 3020
I03.12	M.B51	Productpipe	0619, 1430, 2318, 2319, 2905, 3008
I03.13	M.B53	Ster.air	0619, 1316, 1432
I03.14	M.B61	Cleaning	0619, 2318, 2319, 3103
I03.15	M.B63	Cleaning	0619, 2318, 2319, 3005
I03.16	M.B104	Sterile air	0619, 2318, 2319, 2905, 3008
I03.17	S3	Selector	0615
I04.00	M.B16A,B	Jaw system	0515, 1303
I04.01	Q87,98,99	Overl.prot	0717, 3308
I04.03	M.B85	Perox.bath	0515, 1310

LIST OF ADDRESSES

Address	Position	Function	used in rungs
I04.04	M.B18,62	Sterile air	0609, 0619, 0720
I04.05	M.B48A,B	Per.bath	0515, 0619, 2906, 3109
I04.06	M.B45:2	Hydraulic	1206, 2004, 3116
I04.07	M.B45:4	Hydr.unit	2004, 3114
I04.10	A15.15	Cleaning	2408, 2416
I04.11	A17.15	Spraytank	0906, 0909
I04.12	A18.15	Peroxide	1203, 1207, 1213, 3010
I04.13	A19.15	Separator,	2305, 2905, 3202
I04.14	A22.15	Peroxide	0619, 0707, 0709, 0712, 0714, 3104
I04.15	X100.26	Temp failur	1703
I04.16	X100.27	Failure	1703
I04.17	X1:119	Quemonitor	1220
I05.00	A4:24	Temp.monit	0619, 0806
I05.01	A6:20	Perox.water	0809
I05.02	A6:24	Temp.regul.	0620, 0808, 2003, 3007
I05.03	A8:20	Temp.regul.	0619, 3011
I05.04	A8:24	Temp.regul.	0729, 3011
I05.05	A10:20	Air heater	3203
I05.06	A10:24	Temp.regul.	2904, 3203
I05.07	A13:24	Temp.mon.	0728, 2003, 2603, 3206
I05.10	A14:24	Temp.monit.	1311
I05.11	A30:24	Temp.mon.	1203, 2003, 2603, 3009
I05.12	A202:24	Temp.regul.	0619, 1413, 3019
I05.13	A450:14	S.A. Short	0723
I05.14	A451:14	L.S. Short	0724
I05.15	X1:101	Product at	0621, 1102, 1104, 2803, 3014
I05.16	X1:154	Clean of	1006, 1432, 2321
I06.00	A16A:3	Delay	0505, 9906
I06.01	A16A:4	Design corr	1804, 1816, 1817
I06.02	M.B71	Air inlet	1315
I06.03	M.B92	Perox. bath	0619, 2906, 3106
I06.04	M.B94	Suction	0619, 0620, 1314

LIST OF ADDRESSES

Address	Position	Function	used in rungs
I06.05	M.B20	Final fold. chain pos.	0512
M00.00		Aux. output position 00	ladder 0605, 0608, 0616, *0617, 0620, 0703, 0705, 0706, 0718, 0720, 0727, 1009, 1217, 1905, 2304, 2317, 2402, 2507, 2907, 3004, 3008, 3104, 3106, 3111, 3303, 3304, 3307
M00.01		Aux. output position 10	ladder 0509, 0608, 0610, *0617, 0619, 0620, 0716, 0718, 0722, 0725, 0726, 0728, 0729, 0802, 0803, 0806, 1012, 1413, 3011
M00.02		Aux. output position 20	ladder 0609, 0611, *0617, 0619, 0620, 0729, 0804, 0806, 0902, 0907, 1012
M00.03		Aux. output position 30	ladder 0607, 0613, *0617, 0620, 0729, 0902, 1002, 1102, 1409, 1411, 1412
M00.04		Aux. output position 40	ladder 0611, 0612, 0614, *0617, 0621, 0704, 1106, 1202, 1203, 1220
M00.05		Aux. output position 50	ladder 0611, 0613, 0615, *0617, 0621, 0702, 1203, 1205, 1209, 1428, 1431, 1433, 2803
M00.06		Aux. output position 60	ladder 0602, 0614, 0616, *0618, 0621, 1107, 1202, 1203, 1305, 1428, 1429, 1432, 1438, 1442, 1705, 1803, 1811, 2006, 2316, 2803
M00.07		Aux. output position 70	ladder 0606, 0611, *0618, 0702, 0718, 2304, 2315, 2320, 2405, 3010, 3107
M00.15		Aux. output position 05	ladder 0606, 0609, *0617, 0619, 0620, 0716, 0718, 1413, 3005, 3018, 3103
M00.17		Ladderposition 40-60	*0618, 1102, 1103, 1203, 1806, 2906, 3014
M01.00		Ladderposition 10-70	0718, *0718, 0720, 0805, 0904, 0910, 1012, 2304, 2405, 2907, 3015, 3018, 3109
M01.04		Aux. output position 40	*0612, 1203
M02.00		Output for	*0502, 0509, 0610, 0611, 0613, 0616, 0717, 0803, 1203, 2319, 2404, 2405, 3010
M02.01		Output for	*0503, 0606, 0607, 0608, 0609, 0611, 0613, 0803, 2305

LIST OF ADDRESSES

Address	Position	Function	used in rungs
M02.02		Pulse short stop	*0504, 1821, 2006
M02.03		Output for	*0505, 0615, 1806, 1809, 1810, 1814, 1815, 1816, 1817, 1822
M02.04		Pulse new package	*0506, 1436, 1438, 1913
M02.07		Output for pulse	*0507, 1304
M02.10		Output for pulse	*0508, 1308
M02.12		Output for pulse start	*0509, 2502, 2503, 2504
M02.13		Output pulse	*0510, 1305
M02.15		Output for	*0511, 1434, 1435, 1911, 1912
M02.16		Pulse new station,	*0512, 1306, 1307, 1402, 1404, 1408
M03.00		Pulse	0502
M03.01		Pulse	0503
M03.02		Pulse	0504
M03.03		Pulse	0505
M03.04		Pulse	0506
M03.06		Pulse	1203
M03.07		Pulse	0507
M03.10		Pulse	0507
M03.11		Pulse	0508
M03.12		Pulse	0509
M03.13		Pulse	0510
M03.15		Pulse	0511
M03.16		Pulse	0512
M04.01		Too high machine speed	*1439, *1442, 2802, 3112
M04.02		Spray tank filling fault	0610, *0906, 3205
M04.04		Work environment aseptic	0620, 0702, 0703, 0706, 0717, 0721, 0726, 0805, 0908, 1006, 1009, 1206, 2302, 2303, *2304, *2305, 2308, 2310, 2312, 2314, 2315, 2405, 3004
M04.05		Memory door monitor	0702, 0703, 2303, 2305, *2306, *2307, 2405
M04.07		WEAC stop 15 minutes	2304, 2309, *2310, *2311, 2313
M04.10		WEAC stop 5 or 15 minutes	2303, 2306, *2313, 2314
		chamber stop on	

LIST OF ADDRESSES

Address	Position	Function	used in rungs
M04.11		Pulse	0513
M04.12		Memorycell 1/2 Hz flash	*0513, 0704
M04.14		WEAC stop 5 minutes	2304, *2308, *2309
M04.15		SA shortstop element OK	*0723, 2905, 3019
M04.16		LS shortstop element OK	*0724, 2905, 3011
M05.01		Output for sprink.puls	1433
M05.03		Shiftpulse FFU	1424
M05.04		Memory FFU shiftbit	*1423, 1424, *1424
M05.05		Pulse	9906
M05.07		Inching of FFU in pos. 30	*1411, *1412, 1413
M05.17		Pulse	1411
M06.00		Step up conditions in	0608, 0611, 0613, 0615, 0616, *0621, 0702,
M06.01		Step up conditions in	0703, 0704, 0717, 0803, 1203
M06.04		Demand I for	*0619, 0620, *0620, 0621
M06.05		Demand II for	*2003, 2004
M06.06		Demand III for	*2004, 2005
M06.07		Machine in position	0621, 1202, 1203, *2005, 2006
M06.10		AB9 in machine ladderpos.	0616, 1106, 1107, 1203, 1209, 1305, 1313,
M06.11		AB9 in ladder position	1409, 1416, 1417, 1418, 1428, 1429, 1803,
M06.12		AB9 in ladder position	1820, 2002, 2006, *2006, 2007, 2803
M06.13		Supervision B-valve	0606, 0702, 0706, 0717, 0904, 1206, 1413,
M06.14		Jump to ladder position	2305, 2315, 2317, 2318, 2319, 2322, 2402,
M06.15		Jump to ladder position	2403, 2404, *2405, 2414, 2603, 3005, 3008,
M07.04		Level check peroxide bath	3018, 3103, 3104
		during production	0606, 0702, 1409, 1413, 1414, 1433, 1902,
			1904, 2402, 2403, 2404, *2404, 2413, 2415
			0702, 1413, 1432, *2319, *2320, 2903
			0620, *1316, 2318, 2319, 2320, 2905, 3006
			0620, 2006, *2802, 2803
			0611, *2803
			*1207, 2003, 2603, 3010

LIST OF ADDRESSES

Address	Position	Function	used in rungs
M07.05		Too high level	*0711, *0712, 2004, 3104
M07.12		Prepared for cleaning	1430, *2321, *2322, 3016
M07.13		Memory machineladder	0614, 1204, 2903, *2904, *2906, *2907
M07.14		Putting machineladder	0606, 2602, *2902
M07.15		Putting machineladder	2902, *2903
M07.16		Aux. memory for jump to	*2905, 2906
M07.17		Auxiliary output step	0606, 0607, *0607
M10.00		Manual stop	*0602, *0603, 0614, 0621, 0702
M10.01		Sterileconditions by-	*0604, *0605, 2903
M10.02		Tube flushing on	*1436, 1437
M10.03		Memory signal recieved	*1104, *1105, 1106, 2803
M10.04		Hot water filling,rinsing	*2406, 2409, 2410
M10.05		Malfunction filling	2403, 2404, 2414, *2416, *2417, 3210
M10.06		Transversal	*1705, *1706, 9902
M10.07		Alarm wrong pressure	2005, *2507, *2508, 3304
M10.13		Eject packages after	1903, *1913, *1914
M10.14		1 scanning change bit	*0514, 1418
M10.15		Malfunction during	*0904, *0909, 2311, 2905, 3205
M10.16		Air inlet wrong position	0620, *1315, 2905, 3207
M10.17		Steam fault	0620, *1311, 2318, 2319, 2904, 3018
M11.01		Fault in IH-units	*1702, *1703, 1704, 3108, 9903
M11.07		Long lubrication	1009, *2504, *2505, 2506, 3303
M11.10		Photocell out of function	*1807, *1808, 2803, 3107
M11.11		Position printed design	0614, *1812, *1813, 3107
M11.12		Auxiliary output	1802, *1803, 1807, *9906
M11.15		Memory startvalue after	*1820, *1821, 1822
M11.16		Spraying with hydrogen	0726, 0729, 0902, 0908, *0910, 1002, 1004,
M11.17		Drying after spray H202	1005, 1007, 1011, 2904, 3007, 3011, 3203
M12.00		Tubesealing going on	0611, 0613, 0620, *1005, 2309, 2311
M12.03		Synchronizing MM/FF	0803, *0803
		at start	*1402, *1403, 1404, 1406

LIST OF ADDRESSES

Address	Position	Function	used in rungs
M12.04	Synchronizing MM/FF	at production	1404, *1405, *1406, 1408, 1409, 1414
M12.05	Aux drive unit brake	short stop	*1416, *1417, 1418
M12.06	Auxiliary output clutch		1409, *1409, 1410, 1418, 1430, 1902
M12.07	Auxiliary output inching		*1413, 1414, 1415, 1419
M12.10	Inch conditions		0704, *1413
M12.11	Pressure fault main air		0620, *1010, 2903, 3305
M13.00	Mainsinterrupt to long	for sterile conditions	*2705, 2706, 2903
M13.01	Alarmdelay by restart	after mainsinterrupt	*2703, 2704, 2803, 2903, 2907
M14.00	Auxiliary output	startsequence	0725, 1203, *1204, 1208, 1212, 1213, 1405, 1409, 1414, 1704
M14.01	Auxiliary output	startsequence	1203, *1203, 1204
M14.02	Auxiliary output	stopsequence ext.clean	2407, *2408, *2409, 2410, 2413
M14.03	Pressure fault	sterile air	*0719, *0720, 2905, 3208
M14.04	Memory for closing	heat exchanger valve	*0727, *0728, 0729
M14.10	Line L11-L10 not OK		*0515, 1303, 2707, 2708, 2902, 2903, 2907, 3114, 3116, 3308
M14.11	Line L21-L20 not OK		*0516, 1010, 2903, 3111, 3302, 3303, 3306, 3307, 3308
M14.12	Memory safety monitors		2706, *2707, *2708
M15.00	Max running time machine	with a lubrication fault	2005, *2509
M15.01	Control low level tank		0621, *0707, 0708, *0709, 0710
M15.02	Waterpressure delay		1206, 2305, *2702, 3303
M15.03	Queue monitor		*1220, 2005, 3209
M15.04	Supervision suction valve	position	0620, *1314, 2803, 3204
M15.05	Prolonged filling of	peroxide bath at start	*1209, *1210, 1211, 1214
M15.07	Fault:emergency stop,	jaw,FF rot.	0620, *1309, 1409, 1411, 1413, 1414, 1415, 1418, 2403, 2404
M15.10	Alarm delay unsyncron	MM/FF at production	*1407, *1408, 2004, 3115
M15.11	Jaw system overload		*1302, *1303, 1309, 2802, 3113
M15.12	Paperweb fault		0620, *1302, *1304, 2004, 3013
M15.13	Congestion fault		*1302, *1305, 2004, 3105

LIST OF ADDRESSES

Address	Position	Function	used in rungs
M15.14		Rotation fault FF	*1302, *1306, *1307, 1309, 2802, 3211
M15.15		Strip break	0620, *1302, *1308, 2003, 3017
M15.16		Water pressure fault	0715, *1310, 2802, 3012
M23		Transmission word	*1425
M23.14		Transm. bit	1427
M23.16		Transm. bit	1426
M23.17		Transm. bit	1426
M37.00		1HZ flash	0513, 0702, 0703, 0704, 0708, 0908, 0903, 1003, 2002, 2303, 2407
M37.14		First scan	1008, 2414, 2706
M37.15		Low battery TPMC	3110
M37.16		Scantime 80% exceed.	3110
M37.17		Bit to be shifted by the	*1424, 1436, *1436, 1913, *1913
O14.03	M.Y26	LS counter roller	1217, *1217
O14.04	M.Y24	LS-element movement	*1216, 1218
O14.05	M.Y21	Air knife squeezer roller	*1218, 1437, 1444
O14.06	M.Y20	Short stop element	*1215
O14.07	M.Y18	Peroxide bath top filling	*1214
O14.10	K81	Hydraulic pump	1012, *1206
O14.11	K87/98/Y32	Compressor inlet	0609, 0717, *0717, 0720, 2307
O14.12	K93	Start conveyor	*1219, 1220
O14.13	K94	Unreeling paper supply	*1419, 1420
O14.14	M.Y1	Flap sealing air valve	*1007, 1009
O14.15	M.Y102	Main air valve	*1008, *1009, 1010
O15.00	K14	Bending roller	*1443, *1444
O15.01	K51	Main motor low speed	1206, 1306, *1414, 1415, 1902, 1905, 2404
O15.02	K77	Main motor high speed	0607, 0611, 0711, 1206, 1209, 1210, 1216, 1217, 1304, 1307, 1308, 1404, 1409, 1414, 1415, *1415, 1418, 1423, 1702, 1706, 1902, 1903, 1905, 2502, 2503, 2903, 2905

LIST OF ADDRESSES

Address	Position	Function	used in rungs
O15.03	K82	Peroxide pump	
O15.04	K91	Cleaning system	*1211, 1212, 1213
O15.12	M.Y27	Drop chute	1007, *2413
O15.13	M.Y12	Precorrection	0616, 1305, 1428, 1429, 1902, 1903, *1903, 1904
O15.14	M.Y13	Auto correction, left	*1802, *1803, 1804, 1809, 1818, 1819, *1822
O15.15	M.Y14	Auto correction, right	*1814, *1816, *1818
O16.00	K2	Power Transversal sealing	*1815, *1817, *1819
O16.01	K48	Preheating 1 S.A.	*1704, 2803
O16.02	K71	Air superheater	0620, 0705, *0706, 0714, 0715, 0717, 1012, 1310, 1419, 3019, 3102
O16.03	K75	Heating FF	*0805, 3203
O16.04	K88	Peroxide bath element	*1011
O16.05	K92	Detergent pump	*0715, 0807
O16.06	K96	Preheating 2	*2412
O16.12	K6	Ready for production	*0721, 0723, 0724
O16.13	K26	AB production	*1103, 1105
O16.14	K30	Filling	*1107
O16.15	K46	Signal to CIP	*1108
O16.16	K52	LS sealed tube / LS	0606, 1006, 1430, 2317, 2318, 2319, *2319,
O16.17	K53	Air heater preheating /	2323, 2604, 2903, 3018
O17.00	K54	Peroxide bath, water	*0722
O17.01	K83	Peroxid tank change level	*0806
O17.02	K84	CIP recording	*0808, *0809
O17.03	K95	Sterile parameter	*0713
O17.04	K97	Operational parameter	2323, *2323
O17.10	M.Y19	Air inlet valve	2602, *2602
O17.11	M.Y86	Vacuum valve	2603, *2603, 2604, *2604
O17.12	M.Y25	Heat exchange valve	0721, *0726, 1315, 1430
O17.13	M.Y23	Suction valve	*2314
O17.15	M.Y17/Y51	Central lubrication pump	*0729
		air injection	*0725, 1314
			1012, *2506, 2507, 2508

LIST OF ADDRESSES

Address	Position	Function	used in rungs
O17.16	M.Y9	Product valve (A)	1108, *1432
O17.17	M.Y8	Sterile air valve (B)	*1006, 1316
O20.00	M.Y7	Steam barrier, valve (C)	1430, *1430, 1431, 2904
O20.01	M.Y6	Peroxide bath, fill/drain	1213, *1213
O20.02	M.Y5	Peroxide bath draining	*1212
O20.03	M.Y3	Waste packages	*1902
O20.04	M.Y2	Cleaning tray draining	1433, *2411, 2412
O20.05	M.Y22	Main machine clutch	1216, 1304, 1308, *1410
O20.06	M.Y29	Cleaning system hot water	*2410, 2412, 2415
O20.07	M.Y31	Final folder	*1433
O20.10	M.Y33	Cooling water (outflow)	*1012
O20.11	M.Y34	Spray tank filling	*0905, 1211
O20.12	M.Y35/M.Y4	Spray tank evacuation	*0908
O20.13	M.Y39	Tube flushing	*1437
O20.14	M.Y41	Pull down device	*1426
O21.00	M.Y42	Pressure device FF	*1427
O21.01	M.Y43	Drive unit brake	*1418
O21.02	M.Y63	Brake unreeling paper	*1421
O21.03	M.Y92	Peroxid tank filling	0714, *0714
O21.04	X1.13	Sealing pulse TS left	*9904
O21.05	X1.25	Sealing pulse TS right	*9905
O21.10	A23:A2/P4	Package counter	*1904, 1906
O21.11	A24:A2	Package counter infeed	*1905
O21.12	K105.3	Unreeling motor, start/	1420, *1420
O21.13	K210.3	Beacon	*3004
O21.14	A25:A2	Restart at mainsfailure	*2706
PI0.00	P.S11H	Alarm reset	0711, 0719, 1302, 1407, 1442, 1702, 1808, 2417
PI0.01	P.S12H	Lamp test	3003, 3004
PI0.02		Occup.for int.memory	3002, 3004
PI0.03	P.S2	Inching	0621, 0702, 1203, 1219, 1409, 1413, 1414, 1415, 1430

LIST OF ADDRESSES

Address	Position	Function	used in rungs
PI0.04	P.S3H	Step up	0502, 0603, 0608, 0609, 0614, 0616, 0717, 0803, 1009, 1203, 1409, 1430, 2008, 2404, 2603
PI0.05	P.S4H	Step down	0503, 0602, 0607, 0611, 0621, 2006, 2311, 2319, 2404
PI0.06	P.S6H	No product. allowed	2005
PI0.07	P.S7	Selector switch	0608, 0616, 0702, 0704, 0705, 1413, 1414, 1415, 2005, 2317, 2318, 2319, 2402, 2403, 2404, 3005, 3008, 3018, 3103
PI0.10	P.S19	Drop chute off	1903
PI0.11	P.S20	Stat.chain sprinkler	1433
PL0.00	P.H47	Wrong position of	*3005
PL0.01	P.H48	Wrong position of	*3006
PL0.02	P.H53	Too low temperature	*3007
PL0.03	P.H46	Wrong position of	*3008
PL0.04	P.H52	Too low temperature	*3009
PL0.05	P.H49	Levelfault	*3010
PL0.06	P.H51	Too low temperature	*3011
PL0.07	P.H50	Too low level	*3012
PL0.10	P.H38	Rotation monitor	*3013
PL0.11	P.H45	No product from process	*3014
PL0.12	P.H41	Stripsupply of strip	*3015
PL0.13	P.H44	Cleaning steam barrier	*3016
PL0.14	P.H40	Broken strip of	*3017
PL0.15	P.H43	Temperature out of	*3018
PL0.16	P.H39	Too low temperature	*3019
PL0.17	P.H42	Wrong position of	*3020
PL1.00	P.H37	Supply of paper	*3102
PL1.01	P.H57	Wrong position of	*3103
PL1.02	P.H60	Levelfault peroxide tank	*3104
PL1.03	P.H59	Congestion monitor fault	*3105
PL1.04	P.H56	Wrong position pipe	*3106
PL1.05	P.H55	Position printed	*3107
		cleaning pipe	
		AP-valve B	
		peroxid bath, water	
		product pipe	
		peroxide	
		peroxide bath, peroxide	
		element LS	
		peroxide bath, water	
		paper web fault	
		available at machine	
		applicator too low	
		space	
		stripapplicator	
		limit steam	
		at strip applicator	
		squeezroller, air knife	
		too low	
		cleaning cup	
		draining peroxide bath	
		design out of limits	

LIST OF ADDRESSES

used in rungs

Address	Position	Function	
PL1.06	P.H58	Fault IH-units	*3108
PL1.07	P.H54	Wrong position of	*3109
PL1.10	P.H25	Low battery TPMC, or	*3110
PL1.11	P.H14	Monitor supervisioning	*3111
PL1.12	P.H24	Machine speed too high	*3112
PL1.13	P.H15	Overload jaw system	*3113
PL1.14	P.H23	Too low level	*3114
PL1.15	P.H16	Unsynch. between MM/FF	*3115
PL1.16	P.H22	Too high temperature	*3116
PL2.01	P.H30	Too high level	*3202
PL2.02	P.H31	Too low temperature	*3203
PL2.03	P.H33	Wrong position of	*3204
PL2.04	P.H34	Spray time out of limits	*3205
PL2.05	P.H35	Too low temperature	*3206
PL2.06	P.H36	Wrong position of	*3207
PL2.07	P.H32	Pressurefault sterile air	*3208
PL2.10	P.H63	PLE-equipment	*3209
PL2.11	P.H62	Too low level clean tray	*3210
PL2.13	P.H61	Rotation fault	*3211
PL3.10	P.H21	Too low level	*3302
PL3.11	P.H10	Too low pressure	*3303
PL3.12	P.H20	Wrong pressure	*3304
PL3.13	P.H11	Pressurefault main air	*3305
PL3.14	P.H19	Service switch in	*3306
PL3.15	P.H12	Safety monitors in	*3307
PL3.16	P.H18	Tripped overload	*3308
PL3.17	P.H13	Activated emergency stop	*3309
PO0.01	P.H1:1	Preheating 1	*0705
PO0.02	P.H1:2	Preheating 2	*0716
PO0.03	P.H2:1	Tube sealing	*0802, 1428
PO0.04	P.H2:2	Presterilizing	*0804
		transversal sealing	
		bottom cover peroxid bath	
		scantime 80% exceeded	
		position of tower doors	
		hydraulic oil	
		hydraulic oil	
		separators	
		at air heater	
		suction valve	
		or HI fault	
		at air knife	
		inlet valve	
		final folder	
		lubrication oil	
		cooling water	
		lubrication oil	
		on position	
		of position	
		protection of motors	

LIST OF ADDRESSES

Address	Position	Function	used in rungs
P00.05	P.H3:1	Spraying	*0902, 1106
P00.06	P.H3:2	Drying	*1002
P00.07	P.H4:1	Signal to sterilizer	*1102
P00.10	P.H4:2	Signal from sterilizer	*1106
P00.11	P.H5:1	Start sequence	*1202
P00.12	P.H5:2	Drive motor	*1205
P00.13	P.H6:1	Filling	*1428
P00.14	P.H6:2	Production	*1429
P00.15	P.H7:1	No production allowed	*2002
P00.16	P.H7:2	Production finished	*2315
P00.17	P.H8:1	Work environment aseptic	*2302
		chamber on	
P01		Lampstest of pushbuttons	3003, *3003
P01.00	P.H8:2	W.E.A.C. ready for	*2303
P01.01	P.H9:1	Preparation for cleaning	*2402
P01.02	P.H9:2	Preparation for cleaning	*2317
P01.03	P.H10:1	Cleaning of machine	*2403
P01.04	P.H10:2	Cleaning of valve	*2318
P01.10	P.H2S	Inching	*0704
P01.11	P.H3S	Step up	*0702, 0705, 0716, 0802, 0902, 1102, 1202,
		Step down	2317, 2318, 2402, 2403
P01.12	P.H4S	Step down	*0703
P01.13	P.H6S	No production	*2002
P01.14	P.H11S	Alarm reset	*3002
P01.15	P.A16:1	Design correction	*1804
P01.16	P.P3	Package counter	*1906
R0000		Storage word for positions	*0606, *0608, *0609, *0610, 0611, *0611,
		in machineladder	*0613, *0614, *0615, *0616, 0617, 0618,
			0620, 0705, 0717, 0904, 0910, 1006, 2603
R0010		Storage word shiftregister	1907, *1907, *1913
R0011		Storage word shiftregister	1908, *1908, 1913
R0012		Storage word shiftregister	1909, *1909, 1911, *1911, 1913
R0013		Storage word shiftregister	1910, *1910, 1912, *1912, 1913

LIST OF ADDRESSES

Address	Position	Function	used in rungs
R0014		Package dumping	1913
R0019		Shiftregister pulldown-	*1422, *1424, 1425
R0020		Shiftregister for	*1436
R0021		Shiftreg. tubeflush	1436
R0022		Shiftregister for	1434, *1434, 1436
R0023		Shiftregister for	1435, *1435, 1436
R0100		Storage word for	1706, 9902, *9902, *9903, 9904, 9905
R0254		Storage word time	2703, *2704, 2705
S00.00	30- 35	Drop chute on	1312, 1903
	230-235		
S00.01	155-162	Drop chute off	1903
	355-362		
S00.02	100-277	Side change	1814, 1815, 1816, 1817, 2005, 9904, 9905
S00.03	10- 20	Short stop	0504
	210-220		
S00.04	114-223	Transversal sealing	9903
	314- 23		
S00.05	50- 53	New package	0506
	250-253		
S00.07	130-157	Filling	0615
	330-357		
S00.08	140-167	Filling	0615
	340-367		
S00.09	140-153	Waste pack. blowing	1902
	340-353		
S00.10	6- 14	Design sector	9906
	206-214		
S00.12	3- 20	Printed design corr	1805, 1809, 1810
	203-220		
S00.14	37-160	Synchr MM/ FFU check	1408
	237-360		
S00.15	140-150	Waste pack blowing	1902
	340-350		

LIST OF ADDRESSES

Address	Position	Function	used in rungs
SO0.26	170-177 370-377	Brake	1416
SO0.30	40-107 240-307	Sector for pack.countr	1904
T000		Startsequenzer	*1204
T001		Startsequenzer for	*1204
T003		Maximum time for beeing	*2007, *2008
T005		Delay opening fill.valve	*1431
T006		Circulation of hydrogene-	*1208
T008		Sequenzer external	*2414, *2415
T010		Sequenzer lubrication-	*2503
T011		Sequenzer lubrication-	*2502
T013		Timer WEAC on	*2312
T014		FFU timer synchronization,	*1404
T015		Delay time recording	*2602
T016		Delay time recording	*2603
T023		Tube sealing	*0803
T024		Spray tank evacuation	*0907
T025		Peroxide bath water	*0807
T045		Machine speed timer	*1440
TO000.0	0s1 14s0	Hydr. pump	1206
TO000.1	10s0 15s0	End start- sequenze	0614, 0702, 0712, 0713, 0714, 1102, 1213, 1219, 1415, 1430, 1432, 2003, 2006, 2603,
TO000.2	9s8 10s2	Control per.level	3010, 3104 1203
TO000.3	0s1 9s6	Start sequenze	1106, 1402, 1403, 1418, 1422, 1907, 1908,
TO000.4	9s5 15s0	Contr.temp peroxide	1909, 1910, 1914 3009
TO000.5	3s0 15s0	Delay TS	1703

LIST OF ADDRESSES

Address	Position	Function	used in rungs
TO001.0	8s0 22s0	SQ roller/ air knife	1218
TO001.1	4s5 9s2	Short stop element on	1215
TO001.2	9s0 23s0	LS/RP element on	1216, 1217, 3020
TO001.3	4s0 9s8	Ls counter roller	1217
TO001.4	0s1 1s0	Start sequence	1402
TO003.0	5m00s 6m00s	Short stop time out	2802
TO003.1	0s 4m00s	Cont.light short stop	2002, 2008
TO005.1	33s0 2m00s0	Delay filling out	0621
TO006.0	30s0 31s0	End of H2O2 circulation	1208
TO006.1	0s0 10s0	Top filling perox.pump	1211, 1214
TO006.3	26s0 28s0	Filling perox.bath	0714
TO006.5	29s0 30s0	Contr.level H2O2 tank	0707
TO008.0	22m30s 22m40s	Total ext. clean. time	2403, 2404, 2903
TO008.1	1s 2m20s	First rinse ext. clean.	1433, 2406
TO008.2	3m20s 12m20s	Clean. per. ext. clean.	2406, 2412
TO008.3	13m30s 15m50s	Secnd rinse ext. clean.	1433, 2406
TO008.4	17m00s 19m20s	Third rinse ext. clean.	2406

LIST OF ADDRESSES

Address	Position	Function	used in rungs
TO008.5	19m20s 19m30s	Lubr. after ext. clean	0509
TO010.0	15m00s 15m02s	Time lubric period	2503
TO010.1	2m51s 15m02s	Pause lub- ric.period	2503, 2505
TO010.2	0s 10s	1-st stroke lubricvalve	2506
TO010.3	41s 51s	2-st stroke lubricvalve	2506
TO010.4	1m21s 1m30s	3-st stroke lubricvalve	2506
TO010.5	2m00s 2m10s	4-st stroke lubricvalve	2506
TO011.0	15m00s 15m02s	Time lubric period	2502
TO011.1	2m51s 15m02s	Pause lub- ric.period	2502
TO011.5	2m40s 2m50s	5-th stroke lubricvalve	2506
TO013.0	1h00m00s 1h00m01s	Too long time WEAC	2305
TO013.1	5m00s 1h00m01s	WEAC 5 minutes	2313
TO013.2	15m00s 1h00m01s	WEAC 15 minutes	2313
TO014.0	0s000 6s500	FFU timer end	1404
TO014.1	0s540 0s600	FFU timer producton	1404
TO014.2	0s150 0s270	Pulldown device	1426
TO014.3	0s000 0s280	Press dev./ new station	1424, 1425, 1427

LIST OF ADDRESSES

Address	Position	Function	used in rungs
TO015.0	5m00s	Sterile	2602
	5m02s	record.end	
TO016.0	5m00s	Operational	2603
	5m02s	record.end	
TO023.0	0s0	Tubesealing	0608, 1409, 1413, 1415
	1m00s0	going on	
TO023.2	40s0	Tubesealing	0610
	41s0	ended	
TO023.3	0s7	Tubesealing	0702, 0705, 0716, 0802, 0803, 1006, 1444
	1m00s0	going on	
TO024.0	1s	Spray tank	0908
	30m00s	evac. pos20	
TO024.1	1s	Spray tank	0908
	1m30s	evac. pos20	
TO024.2	1m31s	Spray tank	0620
	31m00s	evac. pos20	
TO025.0	1s	Perox bath	0809
	40m00s	water preh.	
TO025.1	12m00s	Perox bath	0808
	12m01s	water preh.	
TO025.2	13m00s	Perox bath	0809
	40m00s	water preh.	
TO045.0	0s00	Speed test	1439
	59s96	going on	
TV014		Position	1406
		FFU, ms	

RUNG	REFERENCE INSTRUCTION	ADDRESS	VOLUME									
			125 cc	160 cc	236 cc	250 cc	284 cc	200 cc SLIM	250 CC SLIM			
615	PUT R0000	S00.07	100-127 300-327	130-157 330-357	130-157 330-357	130-157 330-357	130-157 330-357	130-157 330-357	130-157 330-357	130-157 330-357	130-157 330-357	130-157 330-357
615	PUT R0000	S00.08	110-137 310-337	140-167 340-367	140-167 340-367	140-167 340-367	140-167 340-367	140-167 340-367	140-167 340-367	140-167 340-367	140-167 340-367	140-167 340-367
506		S00.05	120-123 320-323	50-53 250-253	50-53 250-253	50-53 250-253	50-53 250-253	50-53 250-253	50-53 250-253	50-53 250-253	50-53 250-253	50-53 250-253
9906	L M04.05	S00.10	6-14 206-214	6-14 206-214	6-14 206-214	6-14 206-214	6-14 206-214	6-14 206-214	6-14 206-214	6-14 206-214	6-14 206-214	6-14 206-214
610	PUT R0000	T0023.2	39S0-1M00S0	37S0-1M00S0	34S0-35S0	34S0-35S0	31S0-1M00S0	32S0-1M00S0	32S0-1M00S0	32S0-1M00S0	32S0-1M00S0	29S0-30S0
621	M06.00	T0005.1	35S0-2M00S0	26S0-2M00S0	27S0-2M00S0	27S0-2M00S0	21S0-2M00S0	22S0-2M00S0	22S0-2M00S0	22S0-2M00S0	22S0-2M00S0	17S0-2M00S0
1907	T000.3 PUT R0010	AND	KFC7EH	KFE3EH	KFF IEH	KFF IEH	KFF IEH	KFF IEH	KFF IEH	KFF IEH	KFF IEH	KFF IEH
1908	T000.3 PUT R0011	AND	K3FFFFH	K0FFFFH	K00FFH	K00FFH	K003FH	K003FH	K003FH	K003FH	K003FH	K001FH
1909	T000.3 PUT R0012	AND	K0000H	KF000H	K7FC0H	K7FC0H	KE7FOH	KCFF0H	KCFF0H	KCFF0H	KCFF0H	KF9FCH
1910	T000.3 PUT R0013	AND	KF3FEH	KFFC7H	KFFFEH	KFFFEH	KFFFEH	KFFFEH	KFFFEH	KFFFEH	KFFFEH	KFFFEH
1911	M02.15 I02.06 PUT R0012	AND	KFFFFH	KFFFFH	KE7FFH	KE7FFH	KFE7FH	KFCFFH	KFCFFH	KFCFFH	KFCFFH	KFF9FH
1912	M02.15 I02.06 PUT R0013	AND	KFF3FH	KFFCCH	KFFFFH	KFFFFH	KFFFFH	KFFFFH	KFFFFH	KFFFFH	KFFFFH	KFFFFH
1434	M02.15 PUT R0022	AND	KFFFFH	K9FFFFH	KFCFFH	KFCFFH	KFF3FH	KFF3FH	KFF3FH	KFF3FH	KFF3FH	KFFCFH
1435	M02.15 PUT R0023	AND	KFFE7H	KFFFFH	KFFFFH	KFFFFH	KFFFFH	KFFFFH	KFFFFH	KFFFFH	KFFFFH	KFFFFH
1406	E01.07 E01.07	K- K+	K00010 K00118	K00010 K00118	K00010 K00118	K00010 K00118	K00010 K00118	K00010 K00118	K00010 K00118	K00010 K00118	K00010 K00118	K00118 K00010
1408	M02.16 M10.15	S00.14	37-160 237-360	37-160 237-360	37-160 237-360	37-160 237-360	37-160 237-360	37-160 237-360	37-160 237-360	37-160 237-360	37-160 237-360	17-140 217-340
INTRODUCED ON ECN:	20080		20080	20513			20080	20080	20080	20080	20080	20698

INTRODUCED WITH AM NO	20080	DATE	930909	SIGN.	HK
ISSUE	A				
	B				
	C				
AM NO	20406		20513		
DATE	931015	931129	940427		
SIGN.	HK/MR1	HK/MR1	HK/MR1		
ALTERATIONS ONLY IN CADAM					
DESCRIPTION:			VOLUME ADAPTION DOCUMENT		
MACHINE:			TBA/9-1401 S.A		
			47615-03:01		

LADDER SYMBOLS

LADDER SYMBOL LIGHTS	F		L		F		L		F		L		F		L		F		L		F		L	
	F	L	F	L	F	L	F	L	F	L	F	L	F	L	F	L	F	L	F	L	F	L	F	L
OPERATOR ACTIONS	↑	↑	↑	↑	↑	↑	↑	↑	↑	↑	↑	↑	↑	↑	↑	↑	↑	↑	↑	↑	↑	↑	↑	↑
MACHINE MODE																								
DRIVE MOTOR LOW																								
ON OFF																								
DRIVE MOTOR HIGH																								
ON OFF																								
MAIN MACH. CLUTCH																								
ON OFF																								
DRIVE UNIT .BRAKE																								
ON OFF																								
BENDING ROLLER																								
ON OFF																								
PAPER SUPPLY, MOTOR																								
ON OFF																								
PAPER SUPPLY, MOTOR																								
ON OFF																								
BRAKE UNREEL, PAPER SUPPLY																								
ON OFF																								
TUBE FLUSHING																								
ON OFF																								
LUBR. AIR INJECTION																								
ON OFF																								
PRECORRECTION																								
OFF ON																								
OFF ON																								
OFF ON																								
OFF ON																								
OFF ON																								
POSITION LADDER																								
0 00005 00010 00020 00030 00040 00050 00060 00070																								
20080																								
DATE: 930909																								
SYMBOL: HK/PRI																								
DESCRIPTION: MACHINE OPERATION DIAGRAM																								
MACHINE: TBA/9-1401 S.A.																								
DRAWING REMARKS: 47615-04:01/16																								

LADDER SYMBOL LIGHTS	F			L			F			L			F			L			VALVE CLEANING A B C
	F	L	F	L	F	L	F	L	F	L	F	L	F	L	F	L	F	L	
<b>OPERATOR ACTIONS</b>																			
<b>MACHINE MODE</b>																			
CONVEYOR																			
DN OFF K93																			
DN OFF Y27																			
DN OFF 015.12																			
AIR BLOWING WASTE																			
DN OFF Y3																			
DN OFF 020.03																			
SPRINKLER CHAIN																			
DN OFF Y31																			
COOLING WATER																			
DN OFF Y33																			
DN OFF 020.10																			
DN OFF																			
CIRC. PUMP CLEANING																			
DN OFF K91																			
DN OFF 015.04																			
DRAIN CLEAN TRAY																			
DN OFF Y2																			
DN OFF 020.04																			
HOT WATER CLEAN																			
DN OFF Y29																			
DN OFF 020.06																			
PUMP DETERGENT																			
DN OFF K92																			
DN OFF 016.05																			
OFF ON																			
OFF ON																			
OFF ON																			
ON OFF																			
ON OFF																			
ON OFF																			
ON OFF																			
ON OFF																			
ON OFF																			
POSITION LADDER	0	00005	00010	00020	00030	00040	00050	00060	00070										
DATE: 930909																			
TABLE A																			
REV: 20555																			
REV: 940916																			
REV: HK/MRI																			
DESCRIPTION: MACHINE OPERATION DIAGRAM																			
MACHINE: TBA/9-1401 S.A.																			
DRAWING REMARKS																			
ALTERATIONS ONLY IN CADAM																			





LADDER SYMBOLS

LADDER SYMBOL LIGHTS	F			L			F			L			F			L			VALVE CLEANING A B C			
	F	L	F	F	L	F	F	L	F	F	L	F	F	L	F	F	L	F				
<b>OPERATOR ACTIONS</b>																						
<b>MACHINE MODE</b>																						
COMPRESSOR INLET																						
DN OFF 014.11																						
AIR INLET VALVE																						
SH BYPASS 017.14																						
SUCTION VALVE																						
SH BATH 017.13																						
HEAT EXCHANGER																						
DN OFF 017.12																						
AIR SUPER HEATER																						
BYPASS 016.02																						
AIR SUPER HEAT. 400°C																						
DN OFF 016.17																						
AIR SUPER HEAT 360°C																						
OFF DN 016.17																						
VACUUM VALVE																						
DN OFF 017.11																						
DN OFF																						
DN OFF																						
OFF DN																						
OFF DN																						
OFF DN																						
DN OFF																						
DN OFF																						
DN OFF																						
POSITION LADDER	0	00005	00010	00020	00030	00040	00050	00060	00070													
INTRODUCED BY/AN NO.	20080			DATE: 930909			SIGN: HK/PRI															
ISSUE	A			F = FLASHING LIGHT			L = CONTINUOUS LIGHT															
DATE	20555			ELECTRICALLY ACTIVATED			NORMAL PRESS			LONG PRESS												
DATE	940916			ELECTRICALLY ACTIVATED			NORMAL PRESS			LONG PRESS												
SIGN.	HK/MRI			ELECTRICALLY ACTIVATED			NORMAL PRESS			LONG PRESS												
ALTERATIONS ONLY IN CADAM																						
DESCRIPTION:	MACHINE OPERATION DIAGRAM																					
MACHINE:	TBA/9-1401 S.A.																					
	47615-04:01 5/6																					

This drawing must not without the consent of Tetra Pak be copied, transmitted or disclosed to any third party.

LADDER SYMBOL LIGHTS	F		L		F		L		F		L		F		L		F		L			
	PRE-HEATING 1	PRE-HEATING 2	TIGHT TUBE	PRE-HEAT. III	DRYING	SIGNAL TO STERILE	START SEQUELS	DRIVE MOTOR	FILLING	PROD-UTION	SHORT-STOP-PRODUCTION	END OF PRODUCTION	MEAC	MEAC READY FOR DOOR OPENING	PREPARE FOR EXTERNAL CLEANING	PREPARE FOR EXTERNAL VALVE CLEANING	EXTERNAL CLEANING	VALVE CLEANING				
MACHINE MODE																						
PEROX. TANK, FILLING	Y92																					
ON	OFF																					
PEROX. BATH, WATER PUMP	K99																					
ON	OFF																					
PUMP, PEROXIDE	K82																					
ON	OFF																					
PEROX. BATH, DRAIN.	Y5																					
CLOSED	OPEN																					
PEROX. BATH, FILL.	Y6																					
CLOSED	OPEN																					
PEROX. BATH, TOP FILL.	Y18																					
OPEN	CLOSED																					
SPRAY TANK, FILLING	Y34																					
OPEN	CLOSED																					
AIR SPRAY TANK	Y4, Y35																					
OPEN	CLOSED																					
STERILE AIR VALVE (B)	Y8																					
OPEN	CLOSED																					
STEAM BARRIER (C)	Y7																					
OFF	ON																					
PRODUCTION (A)	Y9																					
ON	OFF																					
READY FOR PRODUCT	K6																					
ON	OFF																					
AB IN PRODUCTION	K26																					
ON	OFF																					
FILLING SIGNAL	K30																					
ON	OFF																					
SIGNAL TO CIP	K46																					
ON	OFF																					
ON	OFF																					
POSITION LADDER		0	00005	00010	00020	00030	00040	00050	00060	00070												
INTRODUCED 3TH AM NO.	20080																					
ISSUE	A																					
AM NO.	20555																					
DATE	940916																					
SIGN.	HK/MRI																					
DESCRIPTION:		MACHINE OPERATION DIAGRAM																				
MACHINE:		TBA/9-1401 S.A.																				
DRAWING REMARKS		47615-04:01 6/6																				

TPMC- PROGRAMME LIST

PULSE AND FLASHGENERATING

0501	05 [BLK]		
0502	Step up P10.04 P.S3H	Pulse M03.00 [P+]	Output for stepup pulse
0503	Step down P10.05 P.S4H	Pulse M03.01 [P+]	Output for stepdown pulse
0504	Short stop S00.03 10-20 210-220	Pulse M03.02 [P+]	Pulse short stop
0505	Delay design sign I06.00 A16A:3	Pulse M03.03 [P+]	Output for designpulse
0506	New package S00.05 50-53 250-253	Pulse M03.04 [P+]	Pulse new package
0507	Paper web I03.05 M.B9	Pulse M03.07 [P+]	Output for pulse rotation paper
0508	Paper web I03.05 M.B9	Pulse M03.10 [P-]	
	Strip break I03.07 M.B33	Pulse M03.11 [P+]	Output for pulse strip break

VOLUME DEPENDENT VALUE. VALID FOR 200CC, FOR OTHER VOLUME SEE:47615-03:01

TPMC - PROGRAMME LIST

0509	Pulse stepup M02.00	Position 10 M00.01	Pulse M03.12 [P+]	Lubr oil low level I02.15 M.B30-A	M02.12	Output for pulse start long lubrication period
	Lubr. after ext. clean I0008.5					
	19m20s					
	19m30s					
	Manual lubrication I02.11	Main air pressure I02.12				
	M.S14	M.B2				
0510	Infeed congestion I03.04	Pulse M03.13 [P+]			M02.13	Output pulse congestion
	M.B44					
0511	Paper splice I03.10	Pulse M03.15 [P+]			M02.15	Output for paper splice pulse
	M.B35					
0512	Final fold. chain pos. I06.05	Pulse M03.16 [P+]			M02.16	Pulse new station, final folder
	M.B20					
0513	1Hz flash M37.00	Pulse M04.11 [P+]			M04.12	Memorycell 1/2 Hz flash
0514					M10.14	1 scanning change bit
0515	Jaw system overload I04.00	Perox.bath water press I04.03	Per.bath cover pos. I04.05		M14.10	Line L11-L10 not OK
	M.B16A,B	M.B85	M.B48A,B			

TPMC-PROGRAMME LIST

0516	Overload protection 102.03 --- / ---	No product. allowed 102.04 --- / ---	Lubr oil low level 102.15 --- / ---	M14.11 ---( )---	Line L21-Li20 not OK
	Q201-Q94	S34-M.S35	M.B30:A		

TPMC-PROGRAMME LIST

POSITIONS MACHINELADDER, STEP UP CONDITIONS

0601	06 [BLK]		
0602	Position 60 M00.06	Step down P10.05 P.S4H	
0603	Step up P10.04 P.S3H	M10.00 (L)	Manual stop of filling
0604	Service switch I02.10 S4	M10.00 (U)	Manual stop of filling
0605	Position 00 M00.00	M10.01 (L)	Sterileconditions by- passed due to service
0606	Reset to zeropos. M07.14	M10.01 (U)	Sterileconditions by- passed due to service
	Aux.output st.downpos3 M07.17		
	Pulse stepdown M02.01		
	Pulse stepdown M02.01		
	Signal to CIP 016,15 K46		
	External cleaning M06.11		
	Ready cleaning M06.10		
	Position 70 M00.07		
	Position 05 M00.15		
	Stop delay from pos. 3 D027 3s0		
	[DON]		
	K00000 [GET]		
	R0000 (PUT)		Storageeword for positions in machineladder

TPMC - PROGRAMME LIST

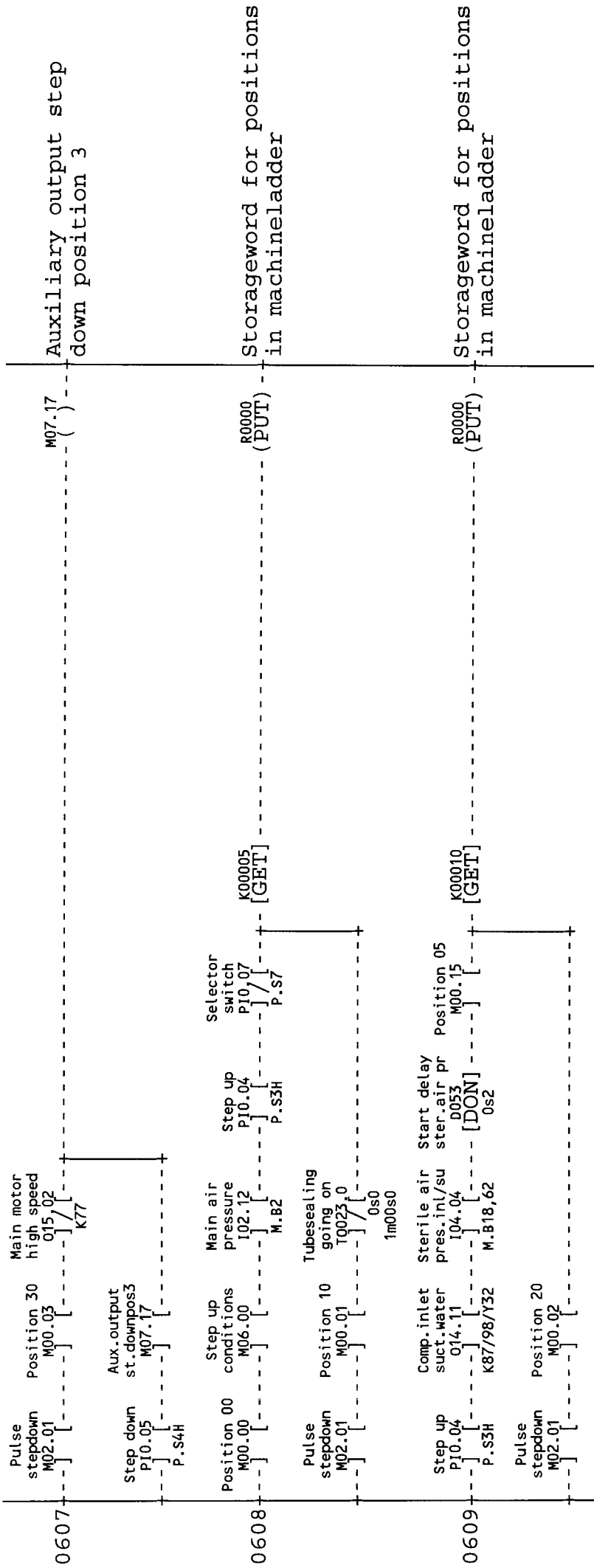

TPMC-PROGRAMME LIST

VOLUME DEPENDENT VALUE. VALID FOR 200CC, FOR OTHER VOLUME SEE:47615-03:01

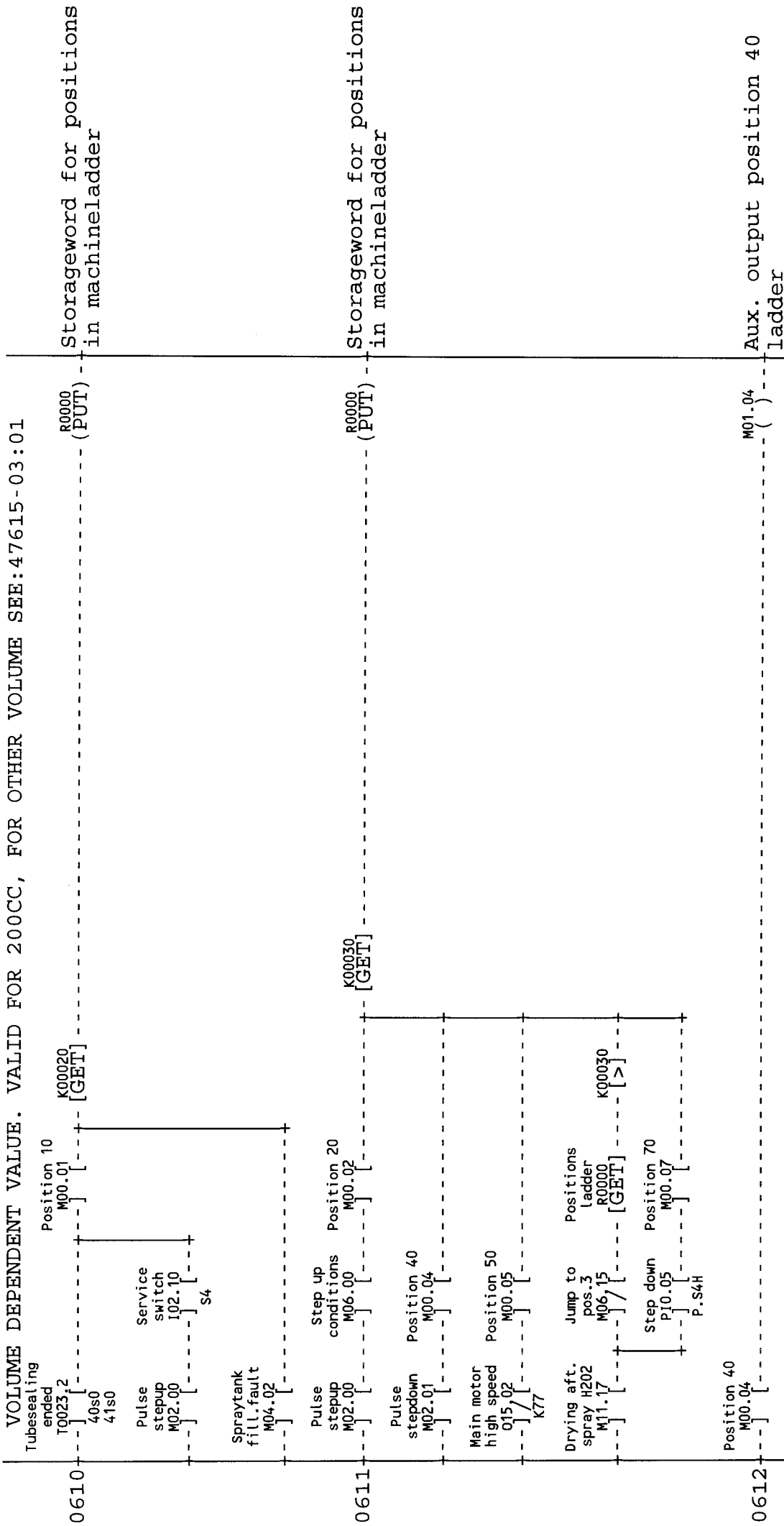

TPMC - PROGRAMME LIST

0613	<p>Pulse stepup M02.00</p> <p>Drying aft. spray M11.17</p> <p>Step up conditions M06.00</p> <p>Position 30 M00.03</p> <p>K00040 [GET]</p> <p>R0000 (PUT)</p> <p>Storage word for positions in machineladder</p>
0614	<p>Pulse stepdown M02.01</p> <p>Position 50 M00.05</p> <p>End start-sequence T0000.1</p> <p>Position 40 M00.04</p> <p>K00050 [GET]</p> <p>R0000 (PUT)</p> <p>Storage word for positions in machineladder</p>
0615	<p>Position 60 M00.06</p> <p>Filling manual off M10.00</p> <p>Memory to zero pos. M07.13</p> <p>Pos. design out of des. monitor M11.11</p> <p>Out of lim. C0001.2</p> <p>0-3</p> <p>VOLUME DEPENDENT VALUE. VALID FOR 200CC, FOR OTHER VOLUME SEE:47615-03:01</p> <p>Designpulse M02.03</p> <p>Selector fill entr. I03.17</p> <p>Filling S00.07</p> <p>Step up conditions M06.00</p> <p>Position 50 M00.05</p> <p>K00060 [GET]</p> <p>R0000 (PUT)</p> <p>Storage word for positions in machineladder</p>

TPMC - PROGRAMME LIST

Address	Position	Step up conditions	Step up	Selector switch	Storage word
0616	M00.00	M06.00	P.33H P.04	P.07 P.07	R0000 (PUT)
	M00.06	M02.00	Short stop on M06.07	Drop chute 015.12 M.Y27	
0617	Positions ladder R0000 [GET]	K00000			Aux. output position 00 ladder
		K00005			Aux. output position 05 ladder
		K00010			Aux. output position 10 ladder
		K00020			Aux. output position 20 ladder
		K00030			Aux. output position 30 ladder
		K00040			Aux. output position 40 ladder
		K00050			Aux. output position 50 ladder
0618	Positions ladder R0000 [GET]	K00060			Aux. output position 60 ladder
		K00070			Aux. output position 70 ladder
		K00030	K00070 [<]		Ladder position 40-60

TPMC-PROGRAMME LIST

0619	Position 05 M00.15	Main air pressure I02.12 M.B2	Productpipe position I03.12 M.B51	Cleaning cup posit. I03.14 M.B61	Cleaning pipe posit. I03.15 M.B63	Sterile air pipe posit. I03.16 M.B104	Sterile air pres.int/su I04.04 M.B18,62	Suction valve posit I06.04 M.B94	M06.01	Step up conditions in machineladder okey
	Position 10 M00.01	Lubr oil low level I02.15 M.B30:A	Peroxide tank level I04.14 A22.15	Temp.regul. LS tubeseal I05.05 A8:20	Temp.regul. SA I05.12 A202:24					
	Position 20 M00.02	Superstruct door posit. I02.02 M.B21A,B,C	Ster. air valve(B)pos I03.13 M.B53	Per.bath cover pos. I04.05 M.B48A,B	Temp.monit presteril. I05.00 A4:24	Perox. bath drain pipe I06.03 M.B92				
0620	Position 00 M00.00	Cool water pressure I02.13 M.B7	WEAC stop on M04.04	Press. fault main air M12.11					M06.01	Step up conditions in machineladder okey
	Position 05 M00.15	Step up conditions M06.01	Supervision B-valve pos M06.13	Air inlet wrong posit M10.16	Steam fault M10.17	Preheating 1 S.A. 016.01 K48				
	Position 10 M00.01	Step up conditions M06.01	Steam fault M10.17	Supervision suct.valve M15.04	Fault:E-stp jaw,FF rot. M15.07	Paperweb fault M15.12	Strip break M15.15			
	Position 20 M00.02	Step up conditions M06.01	Steam fault M10.17	Supervision suct.valve M15.04	Spray tank evac. pos20 I0024:2 1m31s 31m00s					
	Position 30 M00.03	Temp.regul. perox.water I05.02 A6:24	Suction valve posit I06.04 M.B94	Jump to pos.3 M06.14	Drying aft. spray H202 M11.17					
	Service switch I02.10	Positions ladder R0000 [GET]	K00005 [>]	K00040 [<]						
	S4									

TPMC-PROGRAMME LIST

0621 VOLUME DEPENDENT VALUE. VALID FOR 200CC, FOR OTHER VOLUME SEE:47615-03:01

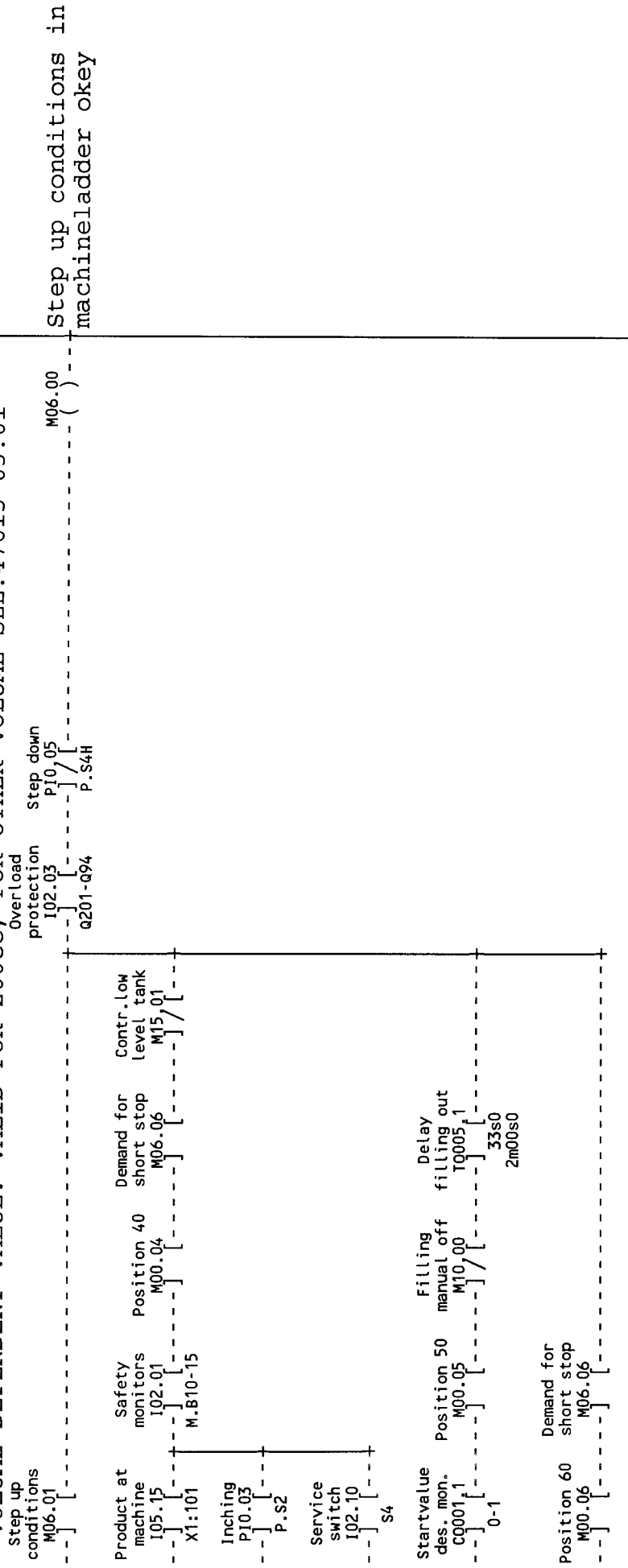

TPMC - PROGRAMME LIST

PREHEATING 1, PEROXID TANK HANDLING AND PREHEATING 2

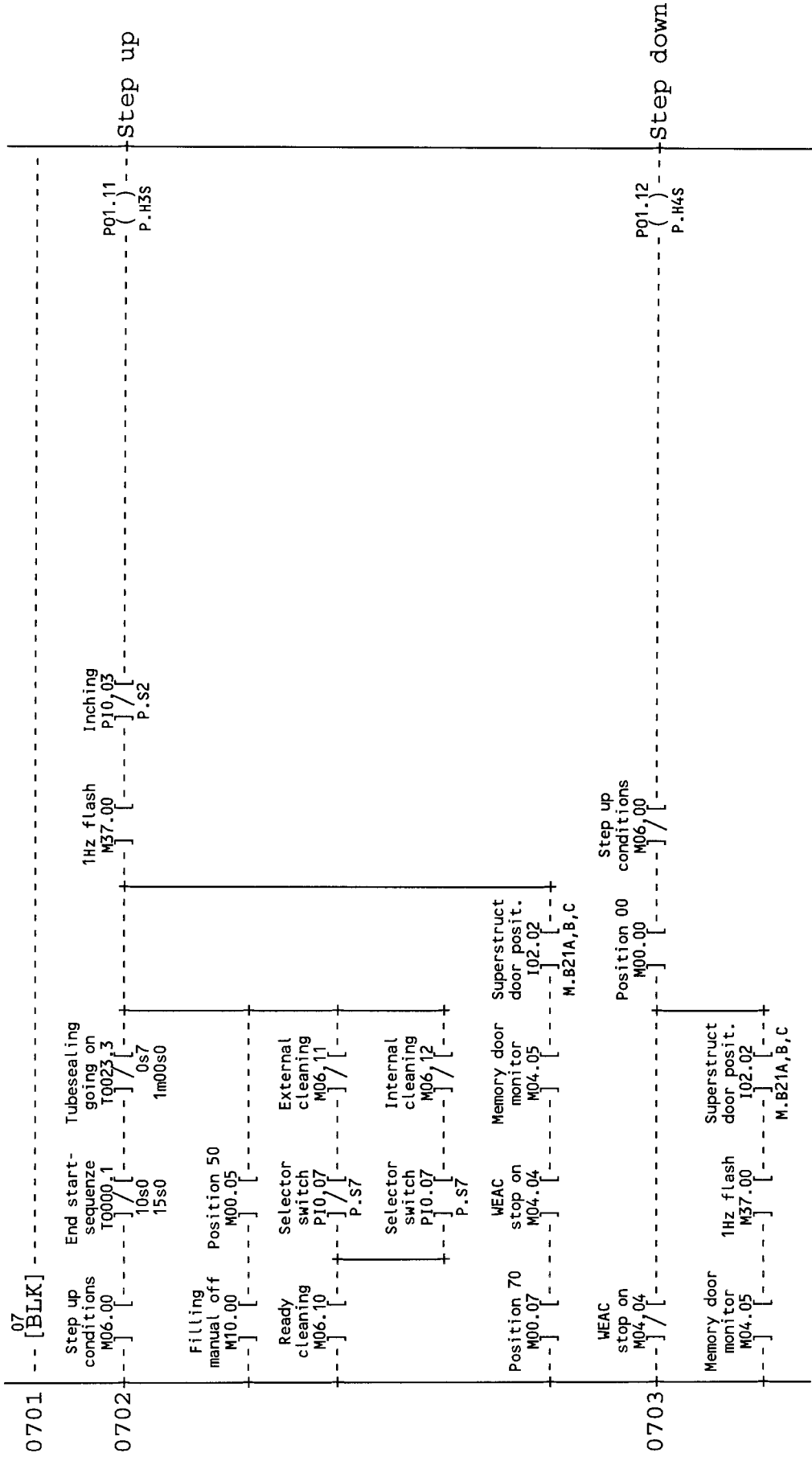

TPMC - PROGRAMME LIST

0704	1/2Hz flash M04.12	Inch condit M12.10	Selector switch PI0.07	P.S7	P01.10 ( )	Inching P.H2S
	1Hz flash M37.00	Inch condit M12.10	Selector switch PI0.07	P.S7		
	Position 40 M00.04	conditions M06.00	1Hz flash M37.00			
0705	Step up P01.11	Selector switch PI0.07	Position 00 M00.00	P.S7	P00.01 ( )	Preheating 1 P.H1:1
	Preheating 1 S.A. 016.01	Positions ladder R0000	Tubesealing going on T0023.3	K00020		
	Main air pressure I02.12	Position 00 M00.00	WEAC stop on M04.04	M.82	016.01 ( )	Preheating 1 S.A. K48
0707	Peroxide tank, level I04.14	Contr.level H202 tank level tank T0006.5	M.time low level tank C0011.1	900-905	M15.01 (L)	Control low level tank
	1Hz flash M37.00	Contr. low level tank M15.01	M.time low level tank C0011.0	900-910	C011 (CTU)	Max.time level tank

TPMC - PROGRAMME LIST

0709	Peroxide tank, level I04.14 A22.15	M15.01 (U)	Control low level tank
0710	Contr. low level tank M15.01	C011 (CTR)	Max. time level tank
0711	Alarm reset P10.00 P.S11H	M07.05 (U)	Too high level peroxide tank
0712	End start- sequence T0000.1 10s0 15s0	M07.05 (L)	Too high level peroxide tank
0713	End start- sequence T0000.1 10s0 15s0	017.01 ( ) K83	Peroxid tank change level
0714	Peroxide tank, level I04.14 A22.15	021.03 ( ) M.Y92	Peroxid tank filling
	Filling perox.bath T0006.3 26s0 28s0		
0715	Water press perox.bath M15.16 1 S.A. K48	016.04 ( ) K88	Peroxide bath element

TPMC-PROGRAMME LIST

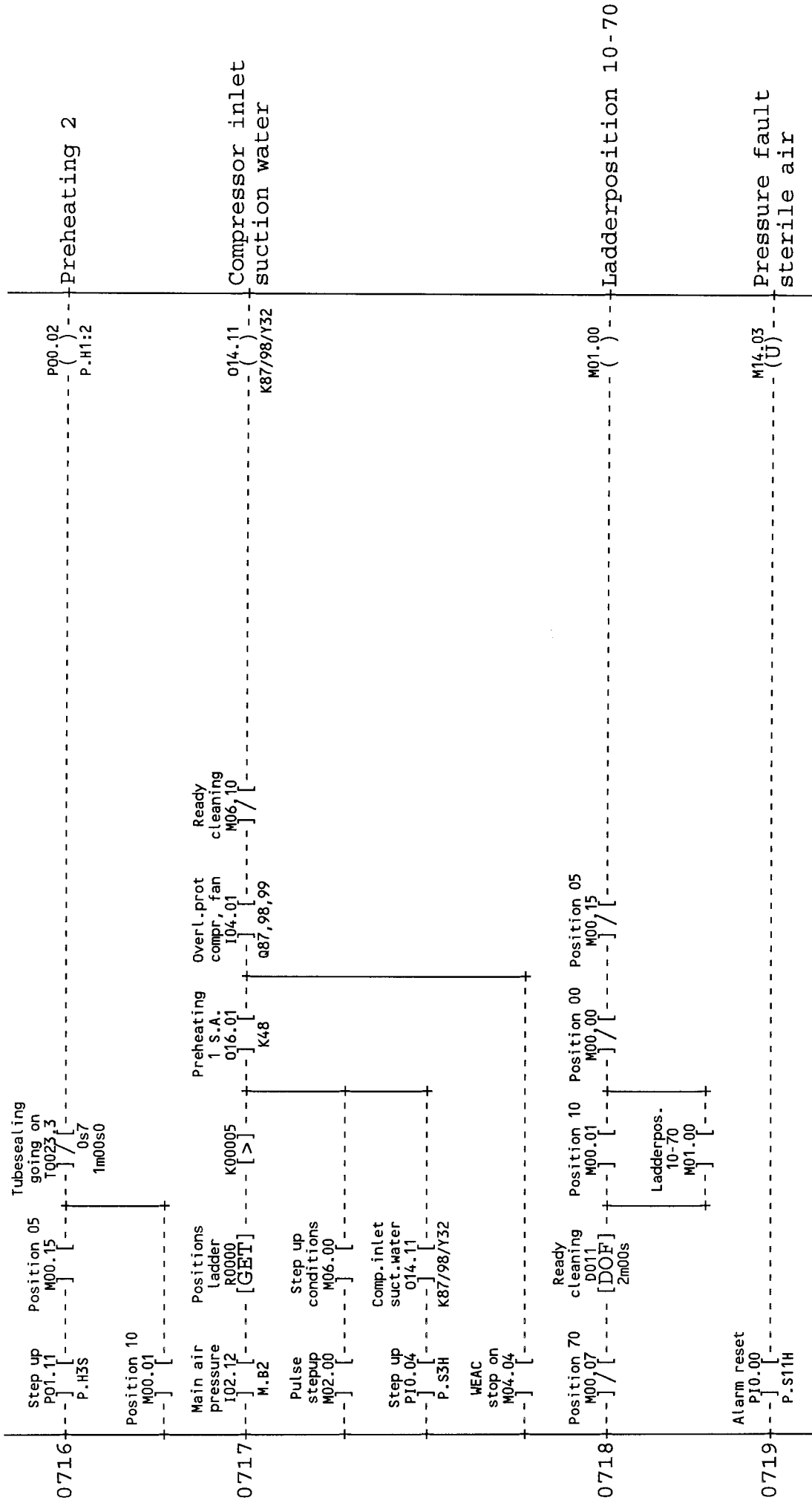

TPMC - PROGRAMME LIST

0720	Ladderpos. 10-70 M01.00 Sterile air pres.inl/su 104.04 M.B18,62 Alarm delay ster.air pr D052 [DON] 2s5	M14.03 (L)	Pressure fault sterile air
0721	Position 00 M00.00 Comp.inlet suct.water 014.11 K87/98/Y32 Sterile air pres.inl/su 104.04 M.B18,62 Air inlet valve WEAC 017.10 M04.04 M.Y19	016.06 ( ) K96	Preheating 2 LS, short stop
0722	Position 10 M00.01	016.16 ( ) K52	LS sealed tube / LS selector
0723	S.A. Short stop broken 105.13 A450:14 Preheat2 LS short stop 016.06 [X] K96 Alarm delay D061 [DOF] 2s0	M04.15 ( )	SA shortstop element OK
0724	L.S. Short stop broken 105.14 A451:14 Preheat2 LS short stop 016.06 [X] K96 Alarm delay D062 [DOF] 2s0	M04.16 ( )	LS shortstop element OK
0725	Position 10 M00.01 Aux.output startsequen M14.00 Suctionvalv house/bath D034 [DOF] 10s0	017.13 ( ) M.Y23	Suction valve

TPMC - PROGRAMME LIST

0726	Position 10 M00.01	Air inlet tower on C0006.2 11-50	017.10 ( ) M.Y19	Air inlet valve
0727	Position 00 M00.00	Spraying hyd.per.f.f M11.16 WEAC stop on M04.04		
0728	Position 10 M00.01	Temp.mon. air knives I05.07 A13:24	M14.04 (L)	Memory for closing heat exchanger valve
0729	Position 10 M00.01	Temp.regul. mem f. heat exch. valve I05.04 M14.04 A8:24	M14.04 (U)	Memory for closing heat exchanger valve
	Position 20 M00.02		017.12 ( ) M.Y25	Heat exchange valve
	Position 30 M00.03	Spraying hyd.per.f.f M11.16 Max emptying time C0005.4 51-110		

TPMC - PROGRAMME LIST

TUBESEALING AND PRESTERILIZING

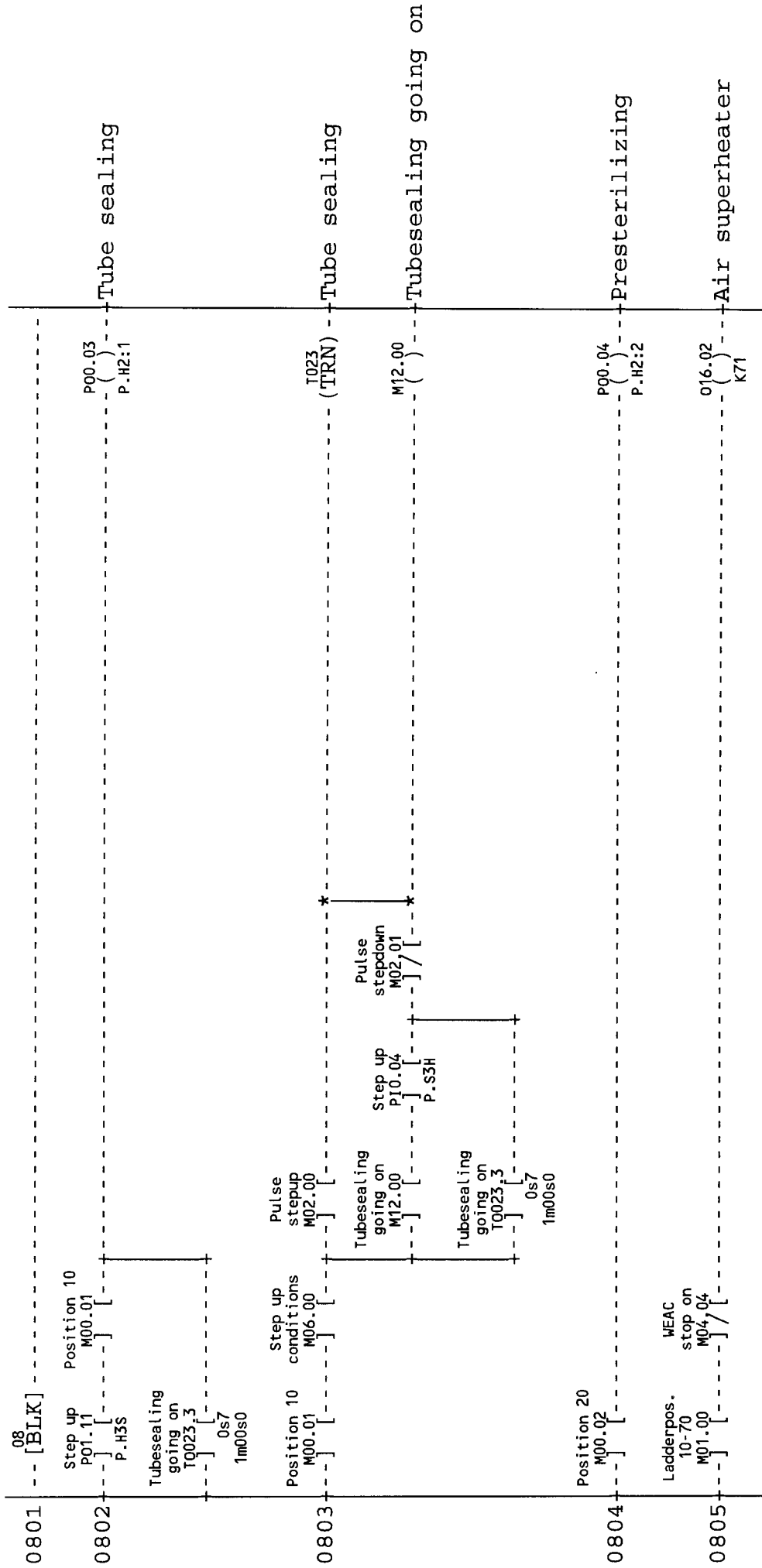

TPMC-PROGRAMME LIST

0806	Position 10 M00.01	016.17 (K53)	Air heater preheating / production 400/360
	Position 20 M00.02		
	Temp.monit presteril. 105.00 A4:24		
0807	Peroxide bath elem. 016.04 K88	1025 (TRN)	Peroxide bath water preheating high temp
0808	Temp.regul. perox.water 105.02 A6:24	017.00 (L) K54	Peroxide bath, water preheating
	Perox bath water preh. 12m00s 12m01s		
0809	Perox.water preheating 105.01 A6:20	017.00 (U) K54	Peroxide bath, water preheating
	Perox bath water preh. 13m00s 40m00s		
	Perox bath water preh. 10025.0 1s 40m00s		

TPMC-PROGRAMME LIST

SPRAYING

0901	09	[BLK]			
0902	Step up P01.11 P.H3S	Position 20 M00.02	Spraying hyd.per.f.f M11.16	P00.05 ( ) P.H3:1	Spraying
0903	Position 30 M00.03	1Hz flash M37.00	Spraying finished C005.0 110-112	C005 (CTU)	Sequencer for spraying of hydrogeneperoxide
0904	Ready cleaning M06.10	Positions ladder R0000 [GET]	K00030 [<]	C006 (CTU)	Sequencer for spraying of hydrogeneperoxid
0905	Ladderpos. 10-70 M01.00	Service switch I02.10 S4		C005 (CTR)	Sequencer for spraying of hydrogeneperoxide
0906	Filling spraytank C0005.1 1-9	Limit perox filling C0006.1 10-10		M10.15 (U)	Malfunction during spraysequenze H2O2
0907	Spraytank quantity I04.11 A17.15			O20.11 ( ) M.Y34	Spray tank filling
0908				M04.02 ( )	Spray tank filling fault

TPMC - PROGRAMME LIST

0907	Position 20 M00.02		I024 (TRN)	Spray tank evacuation before spraying
0908	Spray tank evac. pos20 I0024.0	Spray tank evac. pos20 I0024.1	020.12 ( ) M.Y35/M.Y4	Spray tank evacuation of spraying peroxide
	1s 30m00s	1s 1m30s		
	Spraying hyd.per.f.f M11.16	Spray count contr.steam C0005.2		
		11-112		
0909	Spraytank quantity I04.11	Min empty- ing time C0005.3	M10.15 (L)	Malfunction during spraysequence H2O2
	A17.15	11-20		
	Spraytank quantity I04.11	Max empty- ing time C0005.4		
	A17.15	51-110		
0910	Spraying finished C0005.0		M11.16 ( )	Spraying with hydrogen peroxide fulfilled
	110-112			
	Service switch I02.10	Positions Ladder R0000		
	S4	[GET]		
		K00020		
		[>]		
		Ladderpos. 10-70		
		M01.00		



TPMC-PROGRAMME LIST

1007	Spraying hyd.per.f.f M11.16 [ ]	Delay heat off FF D033 [DOF] 5m00s [ ]		014.14 ( ) M.Y1	Flap sealing air valve
	Clean syst. circ.pump 015.04 [ ]				
	First scan M37.14 [ ]				
1008				014.15 ( ) M.Y102	Main air valve
	Position 00 M00.00 [ ]	WEAC stop on M04.04 [ ]	Long lubr. per.ordered M11.07 [ ]		
1009	Main air valve 014.15 M.Y102 [ ]	Main air pressure D059 [DON] 5s0 [ ]	Flap sealing air 014.14 M.Y1 [ ]	014.15 (U) M.Y102	Main air valve
	Main air valve 014.15 M.Y102 [ ]	Main air pressure I02.12 M.B2 [ ]	Main air check delay D060 [DON] 0s5 [ ]		
1010	Main air valve 014.15 M.Y102 [ ]	Main air pressure D065 [DON] 4s5 [ ]	Step up P10.04 P.S3H [ ]	M12.11 ( ) M.Y102	Pressure fault main air
	Spraying hyd.per.f.f M11.16 [ ]				
1011				016.03 ( ) K75	Heating FF

TPMC - PROGRAMME LIST

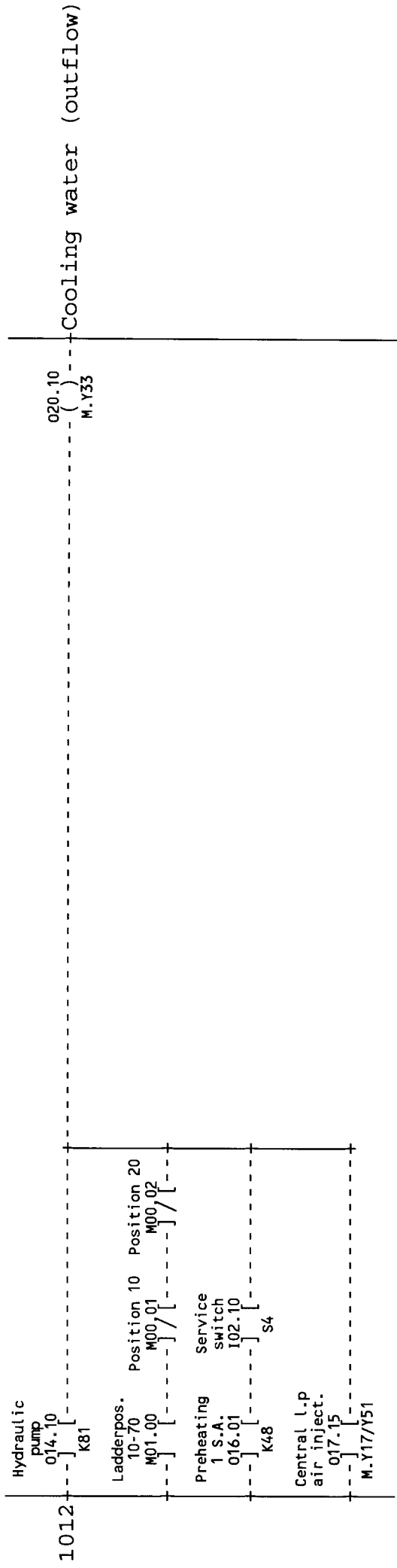

TPMC-PROGRAMME LIST

SIGNALS TO AND FROM STERILIZER

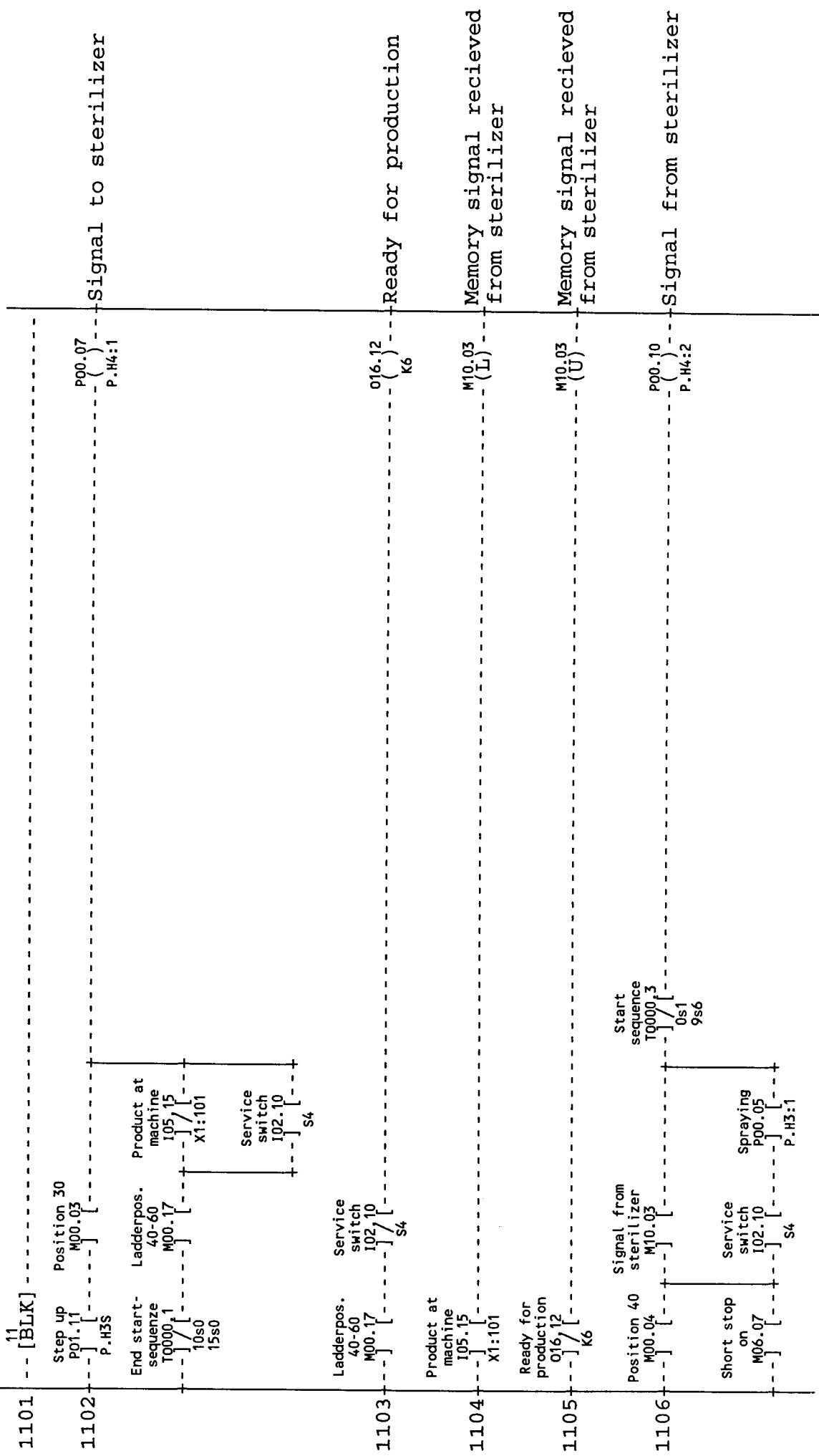

1101 -- [BLK]

1102 Step up P01.11  
Position 30 M00.03  
P.H3S

End start-sequence T0000.1  
Ladderpos. 40-60 M00.17  
Product at machine I05.15  
Service switch I02.10  
S4

Ladderpos. 40-60 M00.17  
Service switch I02.10  
S4

Product at machine I05.15  
X1:101  
Ready for production O16.12 K6

Ready for production O16.12 K6  
Signal from sterilizer M10.03  
Start sequence T0000.3

Position 40 sterilizer M00.04  
Short stop on M06.07  
Signal from sterilizer M10.03  
Service switch I02.10  
Spraying P00.05  
S4

P00.07  
( )  
P.H4:1  
Signal to sterilizer

O16.12  
( )  
K6  
Ready for production

M10.03  
(L)  
Memory signal recieved from sterilizer

M10.03  
(U)  
Memory signal recieved from sterilizer

P00.10  
( )  
P.H4:2  
Signal from sterilizer

TPMC-PROGRAMME LIST

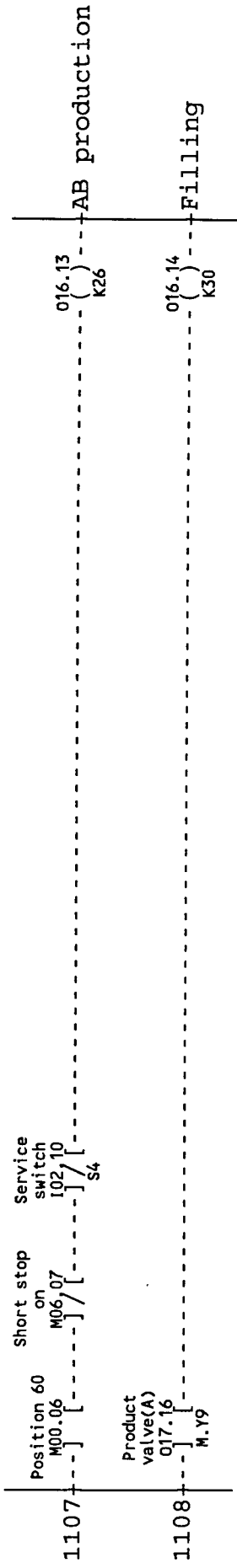

TPMC-PROGRAMME LIST

STARTSEQUENZER FOR RUNNING PRODUCTION

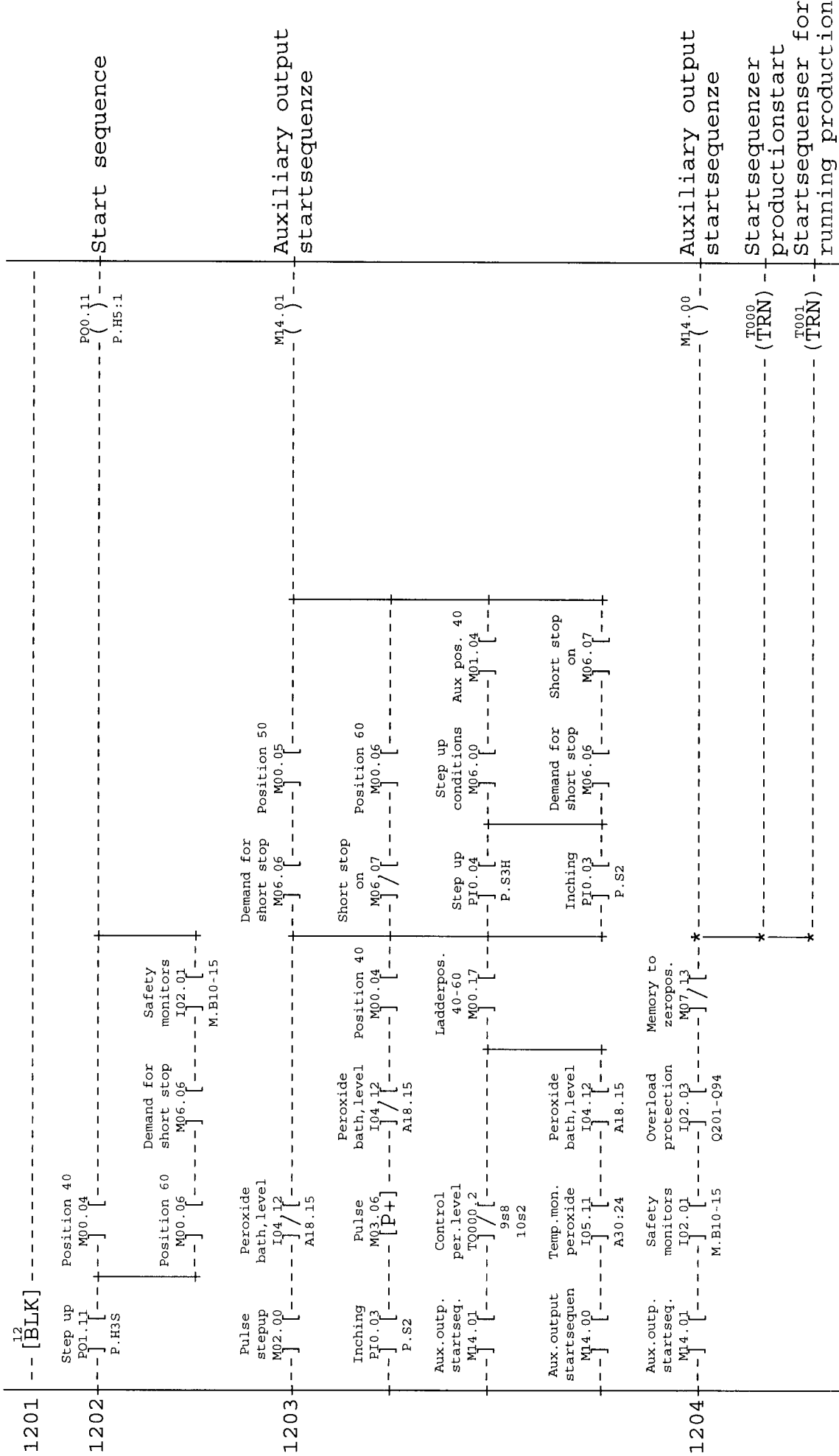

TPMC - PROGRAMME LIST

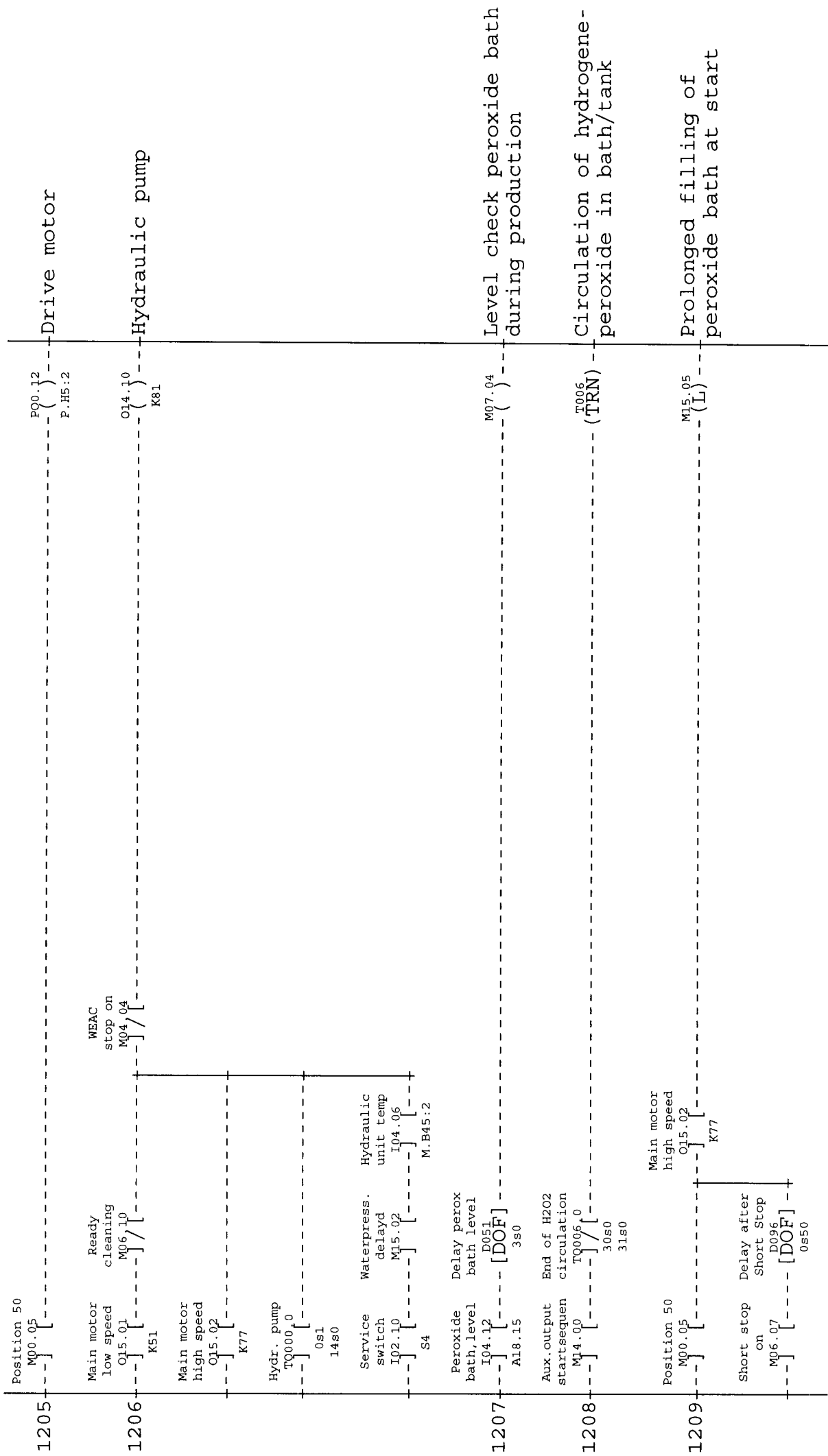

TPMC-PROGRAMME LIST



TPMC-PROGRAMME LIST

1213	<p>Aux. output startsequen M14.00</p> <p>Aux. output startsequen M14.00</p> <p>Perox. bath fill/drain O20.01</p> <p>M. Y6</p> <p>Top filling perox. pump T0006.1</p> <p>0s0 10s0</p> <p>Pro. fill. of perox. bath M15.05</p> <p>Short stop element on T0001.1</p> <p>4s5 9s2</p> <p>LS/RP element on T0001.2</p> <p>9s0 23s0</p> <p>Main motor high speed O15.02</p> <p>K77</p>	<p>Peroxide bath, fill/drain (on=closed)</p> <p>020.01 M. Y6</p> <p>Peroxide bath top filling (on=open)</p> <p>014.07 M. Y18</p> <p>Short stop element movement</p> <p>014.06 M. Y20</p> <p>LS-element movement</p> <p>014.04 M. Y24</p>
------	---	--

TPMC-PROGRAMME LIST

1217	Main motor high speed O15.02 K77	Position 00 M00.00	LS counter roller T0001.3 450 9s8	Superstruct door posit. I02.02 M.B21A,B,C	LS counter roller s.s. O14.03 M.Y26	LS counter roller short stop O14.03 M.Y26
1218	SQ roller/air knife T0001.0 8s0 22s0		LS/element movement O14.04 M.Y24			Air knife squeezer roller O14.05 M.Y21
1219	Inching P10.03 P.S2	End start-sequence T0000.1 10s0 15s0				Start conveyor O14.12 K93
1220	Start conveyor O14.12 K93	Queue monitor P1E equipm. I04.17 X1:119				Queue monitor M15.03
	Position 40 M00.04					

TPMC-PROGRAMME LIST

ROTATION/CONG/FFU/STRIP/JAW/WATER BATH/PAPER SUPPLY/SUCT.,AIR-INLET AND B-VALVE

1301	[BLK]								
1302	Alarm reset P10.00 P.S11H	*						M15.11 (U)	Jaw system overload
		*						M15.12 (U)	Paperweb fault
		*						M15.13 (U)	Congestion fault
		*						M15.14 (U)	Rotation fault FF
		*						M15.15 (U)	Strip break
1303	Jaw system overload I04.00 M.B16A,B		L11-L10 not OK M14.10					M15.11 (L)	Jaw system overload
1304	Main motor high speed O15.02 K77		Main mach. clutch O20.05 M.Y22	Start delay rot.mon.pap D007 [DON] Os70	Pulse rot.paper M02.07	Paper D008 [DON] Os70		M15.12 (L)	Paperweb fault
1305	Position 60 M00.06		Short stop on M06.07	Drop chute O15.12 M.Y27	Pulse congestion M02.13	Delay cong. monitor D047 [DON] 3s0		M15.13 (L)	Congestion fault
1306	Main motor low speed O15.01 K51		St.delay FF rot.monitor D018 [DON] Os70	Pulse new FF-station M02.16	Delay timer FF rot.mon D019 [DON] 3s0			M15.14 (L)	Rotation fault FF
1307	Main motor high speed O15.02 K77		Start delay FF rot.mon. D025 [DON] Os70	Pulse new FF-station M02.16	Delay time FF rot.mon. D026 [DON] Os618			M15.14 (L)	Rotation fault FF

TPMC - PROGRAMME LIST

1308	Main motor high speed 015.02 K77	Main mach. clutch 020.05 M.Y22	Start delay str.rot.mon D046 [DON] 0s70	Pulse strip break M02.10 ]//	Delay strip rotat.monit D045 [DON] 0s70	M15.15 (L)	Strip break
1309	Safety monitors I02.01 M.B10-15	Overload protection I02.03 Q201-Q94	Jaw system overload M15.11 ]//	Rotation fault FF M15.14 ]//		M15.07 ( )	Fault:emergency stop, jaw, FF rot.
1310	Preheating I06.01 K48	Perox.bath water press I04.03 M.B85	Delay super water press D036 [DON] 10s0			M15.16 ( )	Water pressure fault peroxid bath
1311	Temp.monit. steam I05.10 A14:24	Delay super steam mon. D035 [DON] 6s0				M10.17 ( )	Steam fault
1312	Drop chute on S00.00 30-35 230-235	Paper supply I03.00 M.B8				C010 (CTU)	Monitor paper low supply
1313	Paper supply I03.00 M.B8	Short stop on M06.07	Max.run pac low supply C0010.0 150-152			C010 (CTR)	Monitor paper low supply

TPMC-PROGRAMME LIST

1314	Suction valve posit 106.04 M.B94	Suction valve 017.13 M.Y23	Delay stop suct.valve D012 [DOF] 3s0	M15.04 ( )	Supervision suction valve position
	Suction valve posit 106.04 M.B94	Suction valve 017.13 M.Y23			
1315	Air inlet valve pos. 106.02 M.B71	Air inlet valve 017.10 M.Y19	Alarm delay D009 [DOF] 3s0	M10.16 ( )	Air inlet wrong position
	Air inlet valve pos. 106.02 M.B71	Air inlet valve 017.10 M.Y19			
1316	Sterile air valve (B) 017.17 M.Y8	Ster.air valve(B)pos 103.13 M.B53	B-valve pos D013 [DOF] 5s0	M06.13 ( )	Supervision B-valve position
	Sterile air valve (B) 017.17 M.Y8	Ster.air valve(B)pos 103.13 M.B53			

TPMC-PROGRAMME LIST

DRIVEMOTOR AND PRODUCTION

1401	[BLK]			
1402	Start sequence T0000.3 0s1 9s6	Pulse new FF-station M02.16 0s1 1s0	M12.03 (L)	Synchronizing MM/FF at start
1403	Start sequence T0000.3 0s1 9s6		M12.03 (U)	Synchronizing MM/FF at start
1404	Synch.MM/FF at start M12.03 Pulse new FF-station M02.16 Main motor high speed 015.02 FFU timer end T0014.0 0s000 6s500	Synch.MM/FF at product. M12.04 Main motor high speed production T0014.1 FFU timer production T0014.1 0s540 0s600	I014 (TRN)	FFU timer synchronization, production
1405	Aux.output startsequen M14.00		M12.04 (U)	Synchronizing MM/FF at production
1406	Synch.MM/FF at start M12.03 M.M. angle bit 07 E01 M.M. angle bit 07 E01	M.M. angle bit 07 E01.07 M.M. angle bit 07 E01.07 k00010 k00018 k00018	M12.04 (L)	Synchronizing MM/FF at production

VOLUME DEPENDENT VALUE. VALID FOR 200CC, FOR OTHER VOLUME SEE 47615-03:01

TBA/9-1401 S.A.

TPMC-PROGRAMME LIST

1407	Alarm reset PI0.00 P.S11H	M15.10 (U)	Alarm delay unsyncron MM/FF at production
1408	VOLUME DEPENDENT VALUE. VALID FOR 200CC, FOR OTHER VOLUME SEE 47615-03:01 Synchr.MM/FF Pulse new Synchron MM/ at product. FF-station FFU check M12.04 M02.16 S00.14 37-160 237-360	M15.10 (L)	Alarm delay unsyncron MM/FF at production
1409	External cleaning M06.11	M15.07	Fault:E-stp jam, FF rot.
	Tubesealing going on I0023.0 1m00s0	M12.06	Auxiliary output clutch
	Short stop on M06.07		
	Inching PI0.03 P.S2		
	Position 30 M00.03		
	Synch.MM/FF Aux.output at product. startsequen step up M12.04 M14.00 PI0.04 P.S3H		
	Main motor high speed 015.02	M06.07	
	Short stop on M12.06		
	K77		

TPMC-PROGRAMME LIST

1410	Safety monitors I02.01 M.B10-15				020.05 ( ) M.Y22	Main machine clutch
	Aux.output clutch M12.06					
	Crank pos. I02.05 M.B10					
1411	Position 30 M00.03	Pulse M05.17 [P+]	Fault:E-stp jam,FF rot. M15.07		M05.07 (L)	Inching of FFU in pos. 30
1412	Position 30 M00.03				M05.07 (U)	Inching of FFU in pos. 30
1413	Temp.regul. SA I05.12 A202:24	Position 05 M00.15	Crank pos. I02.05 M.B10	Inching PI0.03 P.S2	M12.07 ( )	Auxiliary output inching
	Selector switch PI0.07 P.S7	Position 10 M00.01	Tubesealing going on T0023.0 Os0 1m00s0		M12.10 ( )	Inch conditions
	Ready cleaning M06.10	Internal cleaning M06.12	External cleaning M06.11			
	Inch FFU in position 30 M05.07					

TPMC - PROGRAMME LIST

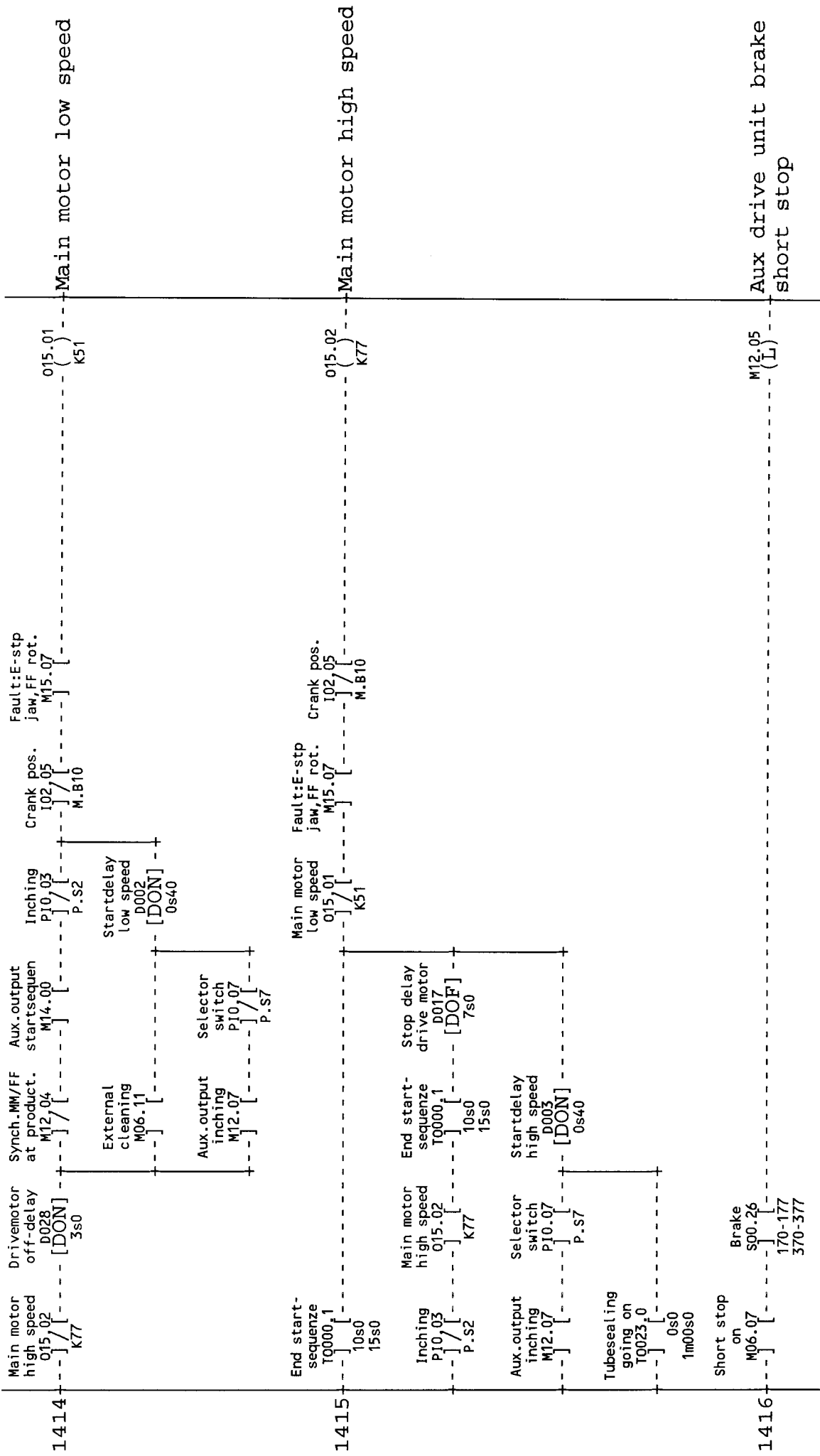

TPMC - PROGRAMME LIST

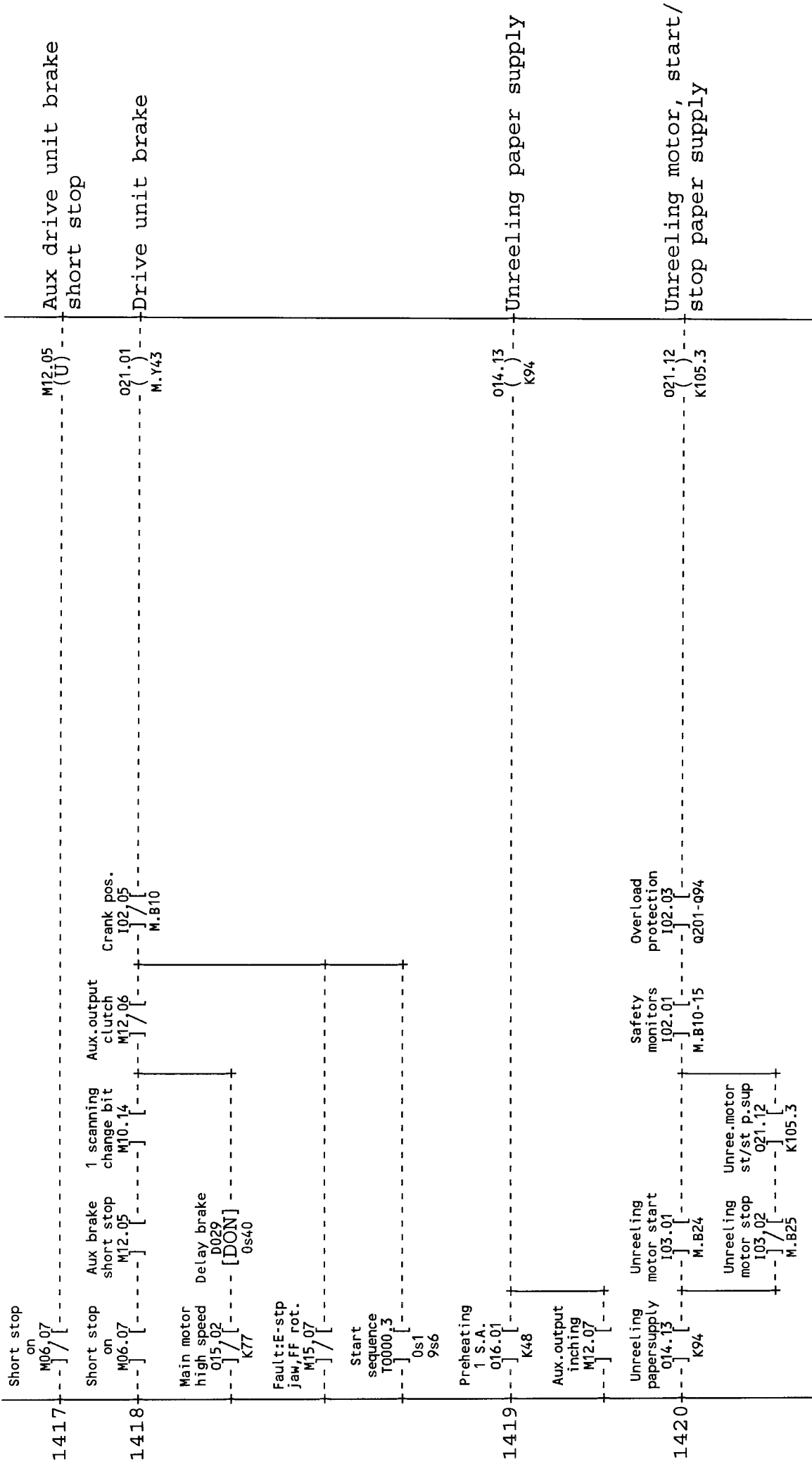

TPMC - PROGRAMME LIST

1421	Unreeling motor stop I03.02 M.B25	021.02 ( ) M.Y63	Brake unreeling paper supply
1422	Start sequence T0000.3 Os1 9s6	R0019 (PUT)	Shifregister pulldown-, pressure device
1423	Infeed congestion I03.04 M.B44	M05.04 (L)	Memory FFU shiftbit
1424	Press dev./ new station T0014.3 Os000 Os280	M37.17 ( )	Bit to be shifted by the shifregister
1425	Press dev./ new station T0014.3 Os000 Os280	R0019 (SHR) M05.04 (U)	Shifregister pulldown-, pressure device Memory FFU shiftbit
1426	Transm. bit M23.17 Os150 Os270	M23 (PUT)	Transmission word
	Transm. bit M23.16	020.14 ( ) M.Y41	Pull down device

TPMC - PROGRAMME LIST

1427	Transm. bit M23.14	Press dev./ new station T0014.3	021.00 ( ) M.Y42	Pressure device FF
1428	Short stop on M06.07	Position 60 M00.06	P00.13 ( ) P.H6:1	Filling
	Tube Sealing P00.03	Position 50 M00.05		
	P.H2:1			
1429	Short stop on M06.07	Position 60 M00.06	P00.14 ( ) P.H6:2	Production
		Drop chute 015.12		
		M.Y27		

TPMC - PROGRAMME LIST

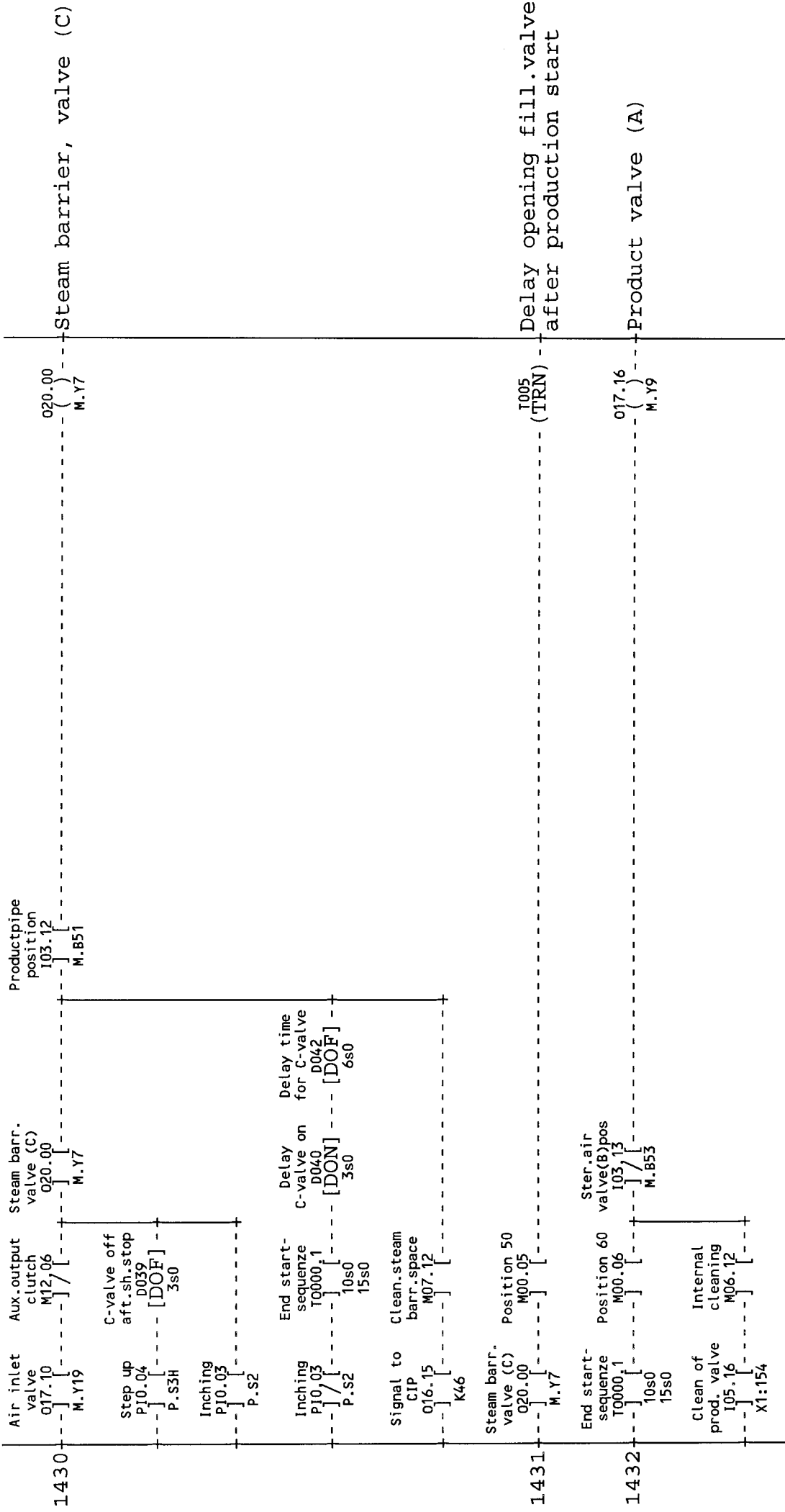

TPMC - PROGRAMME LIST

1433	Position 50 M00.05	Clean.tray draining M06.11	020.04 M.Y2	First rinse ext. clean. T0008.1	1s 2m20s	020.07 M.Y31	Final folder chain sprinkler
				Second rinse ext. clean. T0008.3	13m30s 15m50s		
		Stat.chain sprinkler P10.11	Output for sprink.puls M05.01	Sprinkler time D049			
		P.S20	[P+] [DOF]	25s0			
		VOLUME DEPENDENT VALUE. VALID FOR 200CC, FOR OTHER VOLUME SEE:47615-03:01					
1434	Pulse paperslice M02.15	Shiftreg. tubeflush R0022	[GET]	KFFEEH [AND]		R0022 (PUT)	Shiftregister for tubeflushing
		VOLUME DEPENDENT VALUE. VALID FOR 200CC, FOR OTHER VOLUME SEE:47615-03:01					
1435	Pulse paperslice M02.15	Shiftreg. tubeflush R0023	[GET]	KFFEEH [AND]		R0023 (PUT)	Shiftregister for tubeflushing

TPMC - PROGRAMME LIST

1436	Pulse new package M02.04	M37.17 ( )	Bit to be shifted by the shiftregister
	Air knife squeez.roll 014.05 M.Y21		
1437	Tube flush M10.02	R0020 (SHR)	Shiftregister for tube flushing
	Position 60 M00.06	M10.02 (L)	Tube flushing on
1438	Pulse new package M02.04	M10.02 (U)	Tube flushing on
	Pack. count mach. speed C0009.0 105-106	020.13 ( ) M.Y39	Tube flushing
1439	Speed timer running C0009.1 1-109	C009 (CTU)	Monitor machine speed
1440	New speed test C0009.2 109-110	M04.01 (L)	Too high machine speed
1441	Position 60 Alarm reset M00.06 P.10.00 P.S11h	T045 (TRN)	Machine speed timer
1442		C009 (CTR)	Monitor machine speed
		M04.01 (U)	Too high machine speed

TPMC - PROGRAMME LIST

1443					015.00 (L) K14	Bending roller
1444	Tubesealing going on T0023.3 0s7 1m00s0	Spray and paus time C0005.5 11-109	Air knife squeez.roll 014.05 M.Y21	Run. time drying C0007.2 1080-1140	015.00 (U) K14	Bending roller

TPMC--PROGRAMME LIST

TRANSVERSAL SEALING

1701	17	[BLK]			
1702		Main motor high speed 015.02 K77	Alarm reset P10.00 P.S11H	M11.01 (U)	Fault in IH-units transversal sealing
1703		Temp failur T.S. units 104.15 x100.26	Delay TS T0000.5 3s0 15s0	M11.01 (L)	Fault in IH-units transversal sealing
		Failure T.S. units 104.16 x100.27			
1704		Aux.output startsequen M14.00	Delay TS seal off D023 8s0	016.00 ( ) K2	Power Transversal sealing
1705		Position 60 M00.06	Delay TS off D024 5s0	M10.06 (L)	Transversal sealing on
1706		Main motor high speed 015.02 K77	Storage word TS sealing R0100 K00180 [GET]	M10.06 (U)	Transversal sealing on

TPMC-PROGRAMME LIST

DESIGN CORRECTION

1801	18	[BLK]				
1802		Aux. output precorr off M11.12			015.13 (L) M.Y12	Precorrection
1803		Position 60 M00.06	Short stop on M06.07	Safety monitors I02.01	015.13 (U) M.Y12	Precorrection
1804		Design corr stepping I06.01	Signal des. correction D004	Precorrect. 015.13	M11.12 (U)	Auxiliary output precorrection off
1805		Printed design corr S00.12	[DOF] Os20		P01.15 ( ) P.A16:1	Design correction
1806		Ladderpos. 40-60 M00.17			C000 (CTU)	Printed design photocells out of function
1807		Designpulse M02.03			C000 (CTR)	Printed design photocells out of function
		Photocell pulse prec. C0000.2			M11.10 (L)	Photocell out of function
		Photocell pulse prod. C0000.0	Aux. output precorr off M11.12			

TPMC-PROGRAMME LIST

1808	Alarm reset P10.00 P.S11H		M11.10 (U)	Photocell out of function
1809	Printed design corr S00.12 3-20 203-220	Designpulse M02.03 Precorrect. 015.13 M.Y12	C001 (CTU)	Monitor position printed design out of limit
1810	Printed design corr S00.12 3-20 203-220	Designpulse M02.03 Startvalue des. mon. C0001.1 0-1	C001 (CTD)	Monitor position printed design out of limit
1811	Position 60 M00.06		C001 (CTR)	Monitor position printed design out of limit
1812	Package out of design C0001.0 5-9		M11.11 (L)	Position printed design out of limits
1813	Startvalue des. mon. C0001.1 0-1		M11.11 (U)	Position printed design out of limits
1814	Designpulse M02.03 Side change S00.02 100-277		015.14 (L) M.Y13	Auto correction, left
1815	Designpulse M02.03 Side change S00.02 100-277		015.15 (L) M.Y14	Auto correction, right
1816	Designpulse M02.03 Design corr stepping 106.01 side change S00.02 A16A:4 100-277		015.14 (U) M.Y13	Auto correction, left

TPMC--PROGRAMME LIST

1817	Designpulse M02.03	Design corr stepping I06.01	Side change S00.02	015.15 (U)	Auto correction, right
		A16A:4	100-277	M.Y14	
1818	Precorrect. 015.13			015.14 (U)	Auto correction, left
	M.Y12			M.Y13	
1819	Precorrect. 015.13			015.15 (U)	Auto correction, right
	M.Y12			M.Y14	
1820	Short stop on M06.07			M11.15 (L)	Memory startvalue after short stop
1821	Pulse short stop M02.02			M11.15 (U)	Memory startvalue after short stop
1822	Mem.st.val. aft.sh.stop M11.15	Designpulse M02.03		015.13 (U)	Precorrection
				M.Y12	

TPMC-PROGRAMME LIST

DUMPING OF PACKAGES

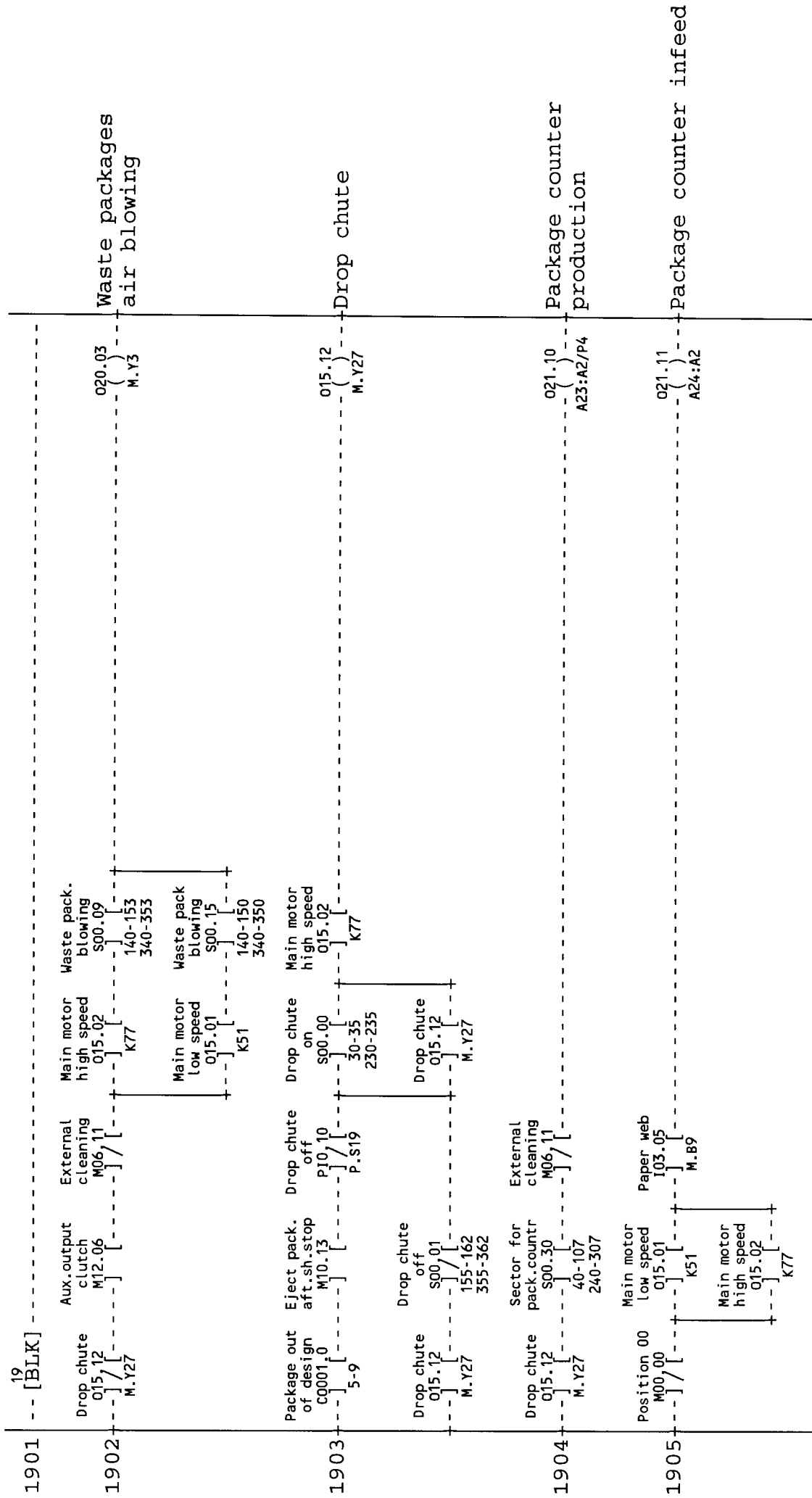

TBA/9 - 1401 S.A.

Sign: H.K.

Date: 930909

AM: 20080

47615-19:01

Page: 1

Cont: 2

TPMC-PROGRAMME LIST

1906	Package counter pr. 021.10 A23:A2/P4	----- P01.16 ( ) P.P3	Package counter production
1907	VOLUME DEPENDENT VALUE. VALID FOR 200CC, FOR OTHER VOLUME SEE:47615-03:01 Start Package dumping sequence R0010 T0000.3 0s1 9s6	----- KFE3EH [AND] ----- R0010 (PUT) -----	Storageword shiftregister packagedumping
1908	VOLUME DEPENDENT VALUE. VALID FOR 200CC, FOR OTHER VOLUME SEE:47615-03:01 Start Package dumping sequence R0011 T0000.3 0s1 9s6	----- K07FEH [AND] ----- R0011 (PUT) -----	Storageword shiftregister packagedumping
1909	VOLUME DEPENDENT VALUE. VALID FOR 200CC, FOR OTHER VOLUME SEE:47615-03:01 Start Package dumping sequence R0012 T0000.3 0s1 9s6	----- KE000H [AND] ----- R0012 (PUT) -----	Storageword shiftregister packagedumping
1910	VOLUME DEPENDENT VALUE. VALID FOR 200CC, FOR OTHER VOLUME SEE:47615-03:01 Start Package dumping sequence R0013 T0000.3 0s1 9s6	----- KFE7FH [AND] ----- R0013 (PUT) -----	Storageword shiftregister packagedumping
1911	VOLUME DEPENDENT VALUE. VALID FOR 200CC, FOR OTHER VOLUME SEE:47615-03:01 Pulse paperslice M02.15 Strip spl. drop chute I02.06 M.S33	----- KFFFFH [AND] ----- R0012 (PUT) -----	Storageword shiftregister packagedumping

TPMC-PROGRAMME LIST

1912	VOLUME DEPENDENT VALUE. VALID FOR 200CC, FOR OTHER VOLUME SEE:47615-03:01 Pulse paperslice M02.15 [GET] KFFE3H [AND] R0013 (PUT) R0013 strip spl. drop chute I02.06 M.S33	Storage word shift register packagedumping
1913	VOLUME DEPENDENT VALUE. VALID FOR 200CC, FOR OTHER VOLUME SEE:47615-03:01 Pulse new package M02.04 M37.17	Bit to be shifted by the shift register Storage word shift register packagedumping Eject packages after short stop
1914	Start sequence T000.3 0s1 9s6 M10.13 (U)	Eject packages after short stop Eject packages after short stop



TPMC - PROGRAMME LIST

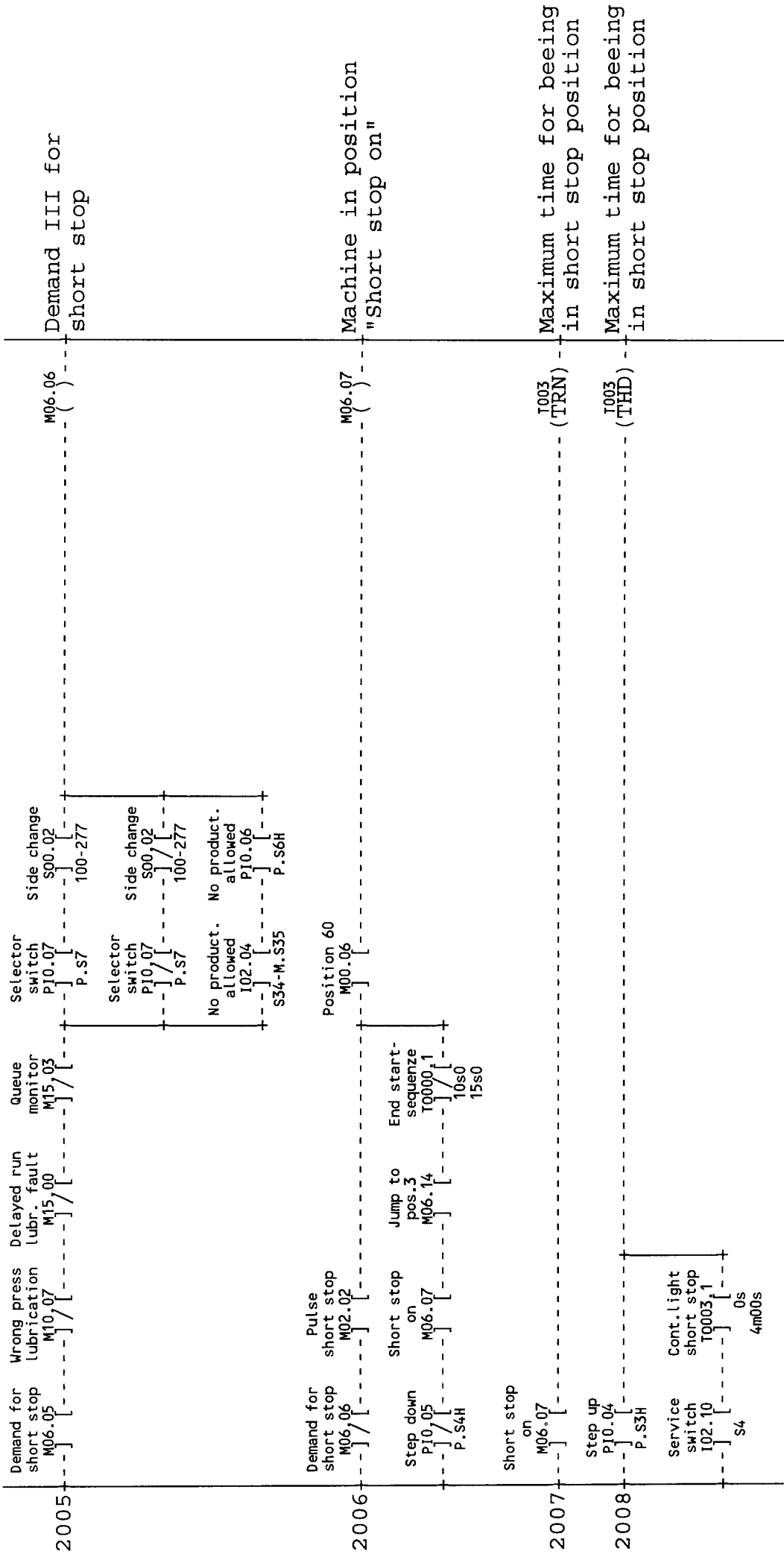



TPMC - PROGRAMME LIST

Programme No.	Event / Description	Code	Event / Description	Code
2305	Superstruct door posit.	I02.02	Memory door monitor	M04.05
	M.B21A,B,C			
	Main air pressure	I02.12		
	M.B2			
	Separator, level	I04.13		
	A19.15			
	Waterpress. delayd	M15.02		
	Ready cleaning	M06.10		
	Too long time WEAC	T0013.0		
	1h00m00s 1h00m01s			
2306	Superstruct WEAC stop door posit. 5 or 15 min	M04.10	Memory door monitor	M04.05 (L)
	M.B21A,B,C			
	Comp.inlet suct.water	O14.11	Memory door monitor	M04.05 (U)
2307	K87/98/132			
	WEAC stop on	M04.04	WEAC stop 5 minutes	M04.14 (U)

Work environment aseptic chamber stop on

TPMC - PROGRAMME LIST

2309	Service switch I02.10 S4	WEAC stop 15 minutes M04.07	Drying aft. spray H202 M11.17	M04.14 (L)	WEAC stop 5 minutes
2310	WEAC stop on M04.04			M04.07 (U)	WEAC stop 15 minutes
2311	Service switch I02.10 S4	Spray fault M10.15	Drying aft. spray H202 M11.17	M04.07 (L)	WEAC stop 15 minutes
	Spray count contr. steam C0005.2	Step down P.I0.05			
	11-112	P.S4H			
2312	WEAC stop on M04.04			T013 (TRN)	Timer WEAC on
2313	WEAC 5 minutes T0013.1 5m00s 1h00m01s	WEAC stop 15 minutes M04.07		M04.10 ( )	WEAC stop 5 or 15 minutes
	WEAC 15 minutes T0013.2 15m00s 1h00m01s				
2314	WEAC stop on M04.04	WEAC stop 5 or 15 min M04.10		017.11 ( ) M.Y86	Vacuum valve
2315	Position 70 M00.07	WEAC stop on M04.04	Ready cleaning M06.10	P00.16 ( ) P.H7:2	Production finished

TPMC - PROGRAMME LIST

JUMP TO BLOCK 25, WHEN THE MACHINE ARE IN PRODUCTION MODE (POS.6) .

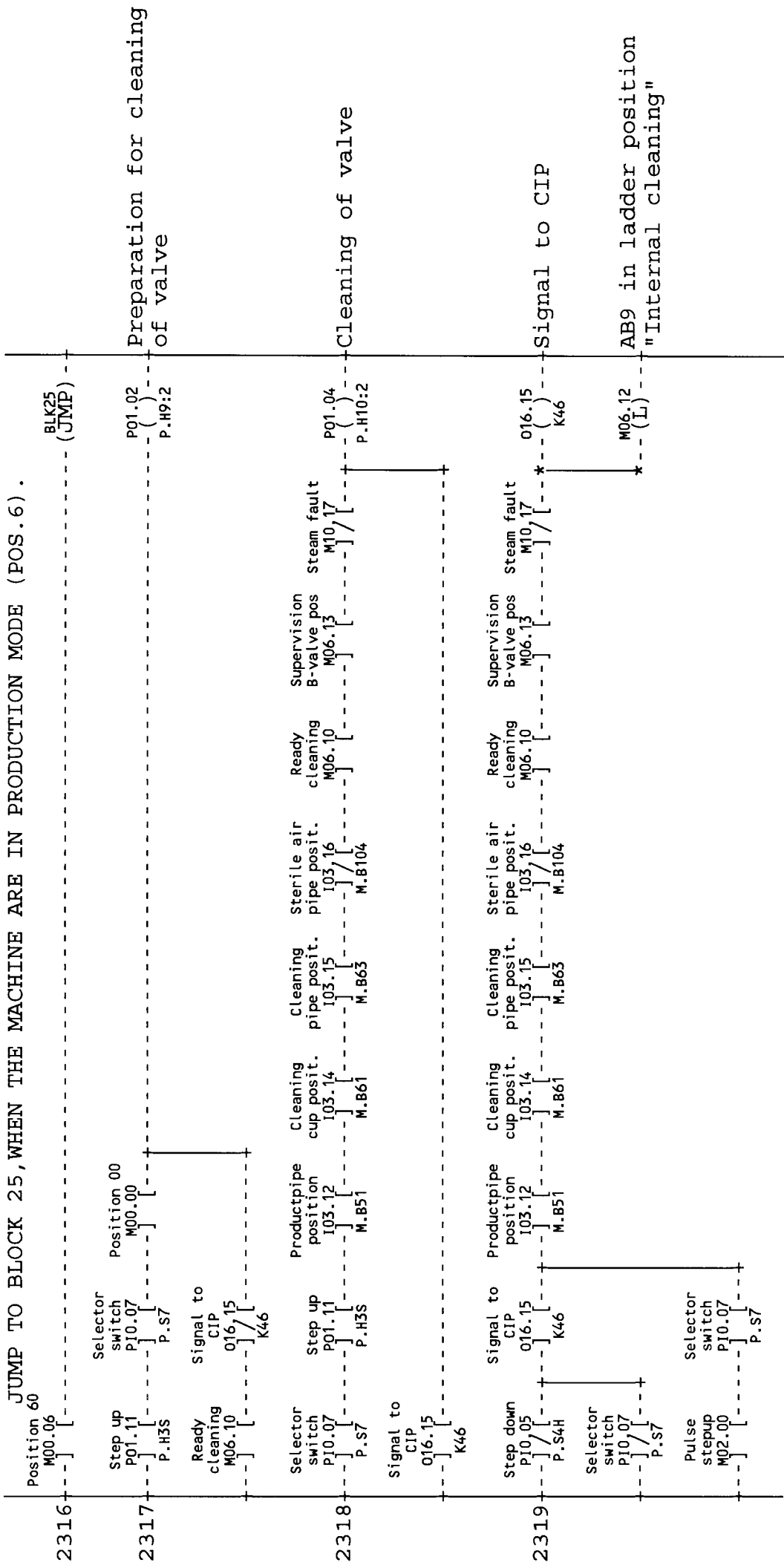

TPMC - PROGRAMME LIST

2320	Position 70 M00.07 / [-----] Supervision B-valve pos M06.13 / [-----]	M06.12 --(U)-----	AB9 in ladder position "Internal cleaning"
2321	Clean thru steam barr. I02.07 S2 Clean of prod. valve I05.16 X1:154	M07.12 --(L)-----	Prepared for cleaning steambarrier space
2322	Ready cleaning M06.10 / [-----]	M07.12 --(U)-----	Prepared for cleaning steambarrier space
2323	Signal to CIP 016.15 / [-----] K46	017.02 --( )----- K84	CIP recording

TPMC-PROGRAMME LIST

EXTERNAL CLEANING

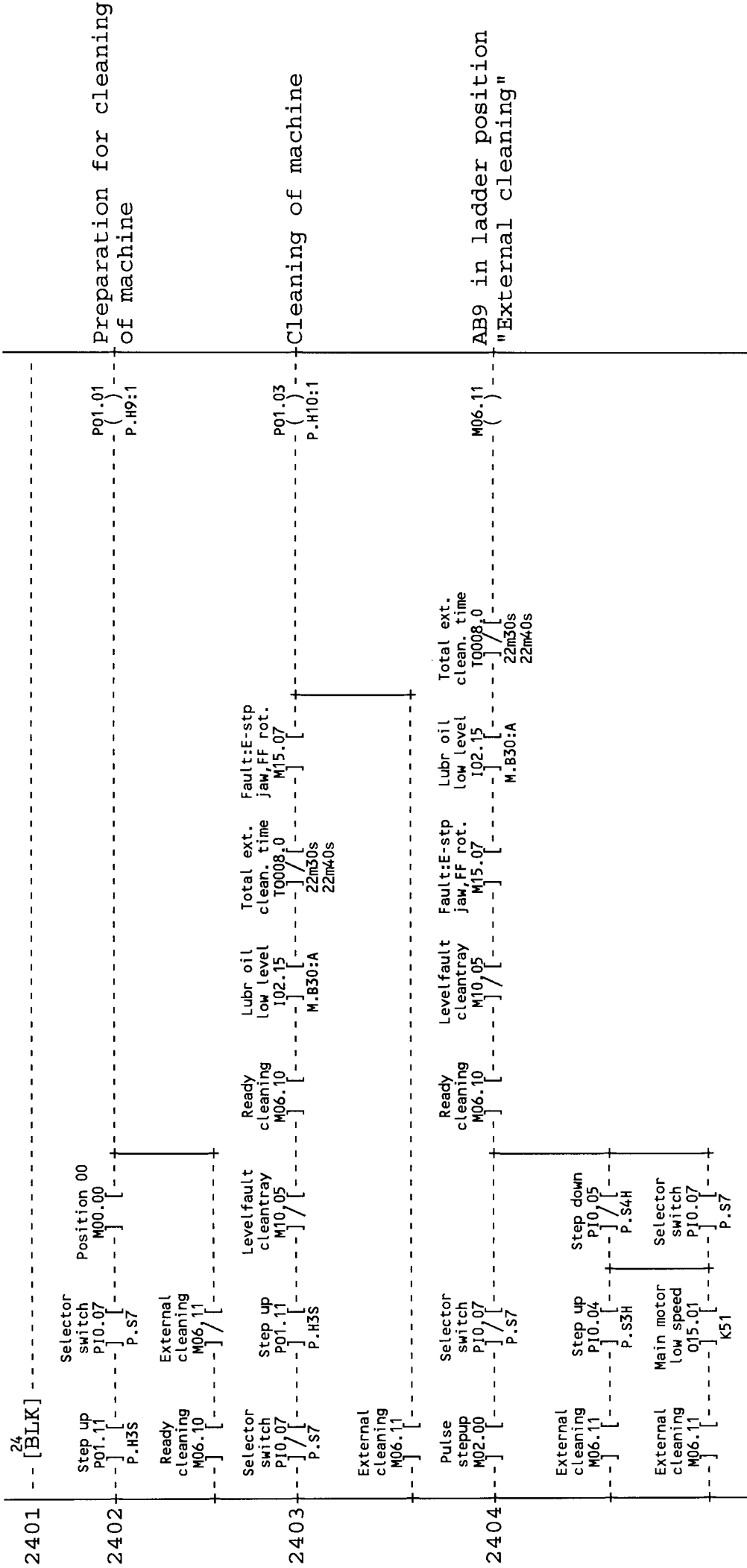

TPMC - PROGRAMME LIST

2405	<p>Position 70 M00.07</p> <p>Superstruct door posit. I02.02</p> <p>M.B21A,B,C</p> <p>Ladderpos. 10-70 M01.00</p> <p>WEAC stop on M04.04</p> <p>Pulse stepup M02.00</p> <p>WEAC stop on M04.04</p> <p>Memory door monitor M04.05</p> <p>M06.10</p> <p>AB9 in machine ladderpos. "Ready for cleaning"</p>
2406	<p>First rinse ext. clean. T0008.1</p> <p>1s</p> <p>2m20s</p> <p>Clean. per. ext. clean. T0008.2</p> <p>5m20s</p> <p>12m20s</p> <p>Second rinse ext. clean. T0008.3</p> <p>13m30s</p> <p>15m50s</p> <p>Third rinse ext. clean. T0008.4</p> <p>17m00s</p> <p>19m20s</p> <p>Aux.outp. stops.ext.c M14.02</p> <p>1Hz flash M37.00</p> <p>Cleaning tray,level I04.10</p> <p>A15.15</p> <p>Delay fill. cleantray D010</p> <p>[DON] 4s0</p> <p>Allowed fillingtime C002.1</p> <p>110-600</p> <p>M10.04</p> <p>Hot water filling, rinsing and cleaning in ext. clean</p>
2407	<p>C002 (CTU)</p> <p>Sequencer filling of cleantray by ext. cleaning</p>
2408	<p>M14.02 (L)</p> <p>Auxiliary output stopsequence ext. clean</p>

TPMC - PROGRAMME LIST

2409	Hot water filling M10.04	M14.02 (U)	Auxiliary output stopsequence ext.clean
			Sequencer filling of cleantray by ext.cleaning
2410	Hot water filling M10.04	020.06 ( ) M.Y29	Cleaning system hot water
	Aux.outp. stops.ext.c M14.02		
2411	Draining time C0002.3	020.04 ( ) M.Y2	Cleaning tray draining
	0-20		
2412	Clean.syst. hot water 020.06	016.05 ( ) K92	Detergent pump
	Clean.tray draining 020.04		
	M.Y2		
	Clean.per.ext.clean. TQ008.2		
	3m20s		
	12m20s		
2413	External cleaning M06.11	015.04 ( ) K91	Cleaning system circulation pump
	Aux.outp. stops.ext.c M14.02		
2414	Ready cleaning M06.10	I008 (TRN)	Sequencer external cleaning program
	Levelfault cleantray M10.05		
	First scan M37.14		
2415	Clean.syst. hot water 020.06	I008 (THD)	Sequencer external cleaning program
	M.Y29		
	External cleaning M06.11		

TPMC - PROGRAMME LIST

2416	Cleaning tray, level I04.10 A15.15	Min filling time C0002.2 100-110	M10.05 (L)	Malfunction filling cleantray by cleaning
2417	Max filling time C0002.4 570-572	Alarm reset P10.00 P.S11H	M10.05 (U)	Malfunction filling cleantray by cleaning



TPMC - PROGRAMME LIST

Program No.	Description	Start Time	End Time	Remarks
2506	2-st stroke lubricvalve T0010.3 41s 51s 3-st stroke lubricvalve T0010.4 1m21s 1m30s 4-st stroke lubricvalve T0010.5 2m00s 2m10s 5-th stroke lubricvalve T0011.5 2m40s 2m50s 1-st stroke lubricvalve T0010.2 0s 10s	M11.07	M17.15	Central lubrication pump air injection
2507	Central l.p air inject. 017.15 M.Y17/Y51 Delay s.vis lubr.press. 0021 [DON] 8s0 Lubr.oil pressure 102.14 M.B6 Delay s.vis lubr.press. 0020 [DON] 15s0	M10.07	M10.07	Alarm wrong pressure during lubrication
2508	Central l.p air inject. 017.15 M.Y17/Y51 Lubr.oil pressure 102.14 M.B6	M10.07	M10.07	Alarm wrong pressure during lubrication

TPMC - PROGRAMME LIST

2509	Lubr oil low level 102,15 M.B30:A	Max runtime lubr. fault 0030 [DON] 59m59s	M15.00 ( )	Max running time machine with a lubrication fault
------	---	---	---------------	--

TPMC - PROGRAMME LIST

6 - CHANNEL RECORDER

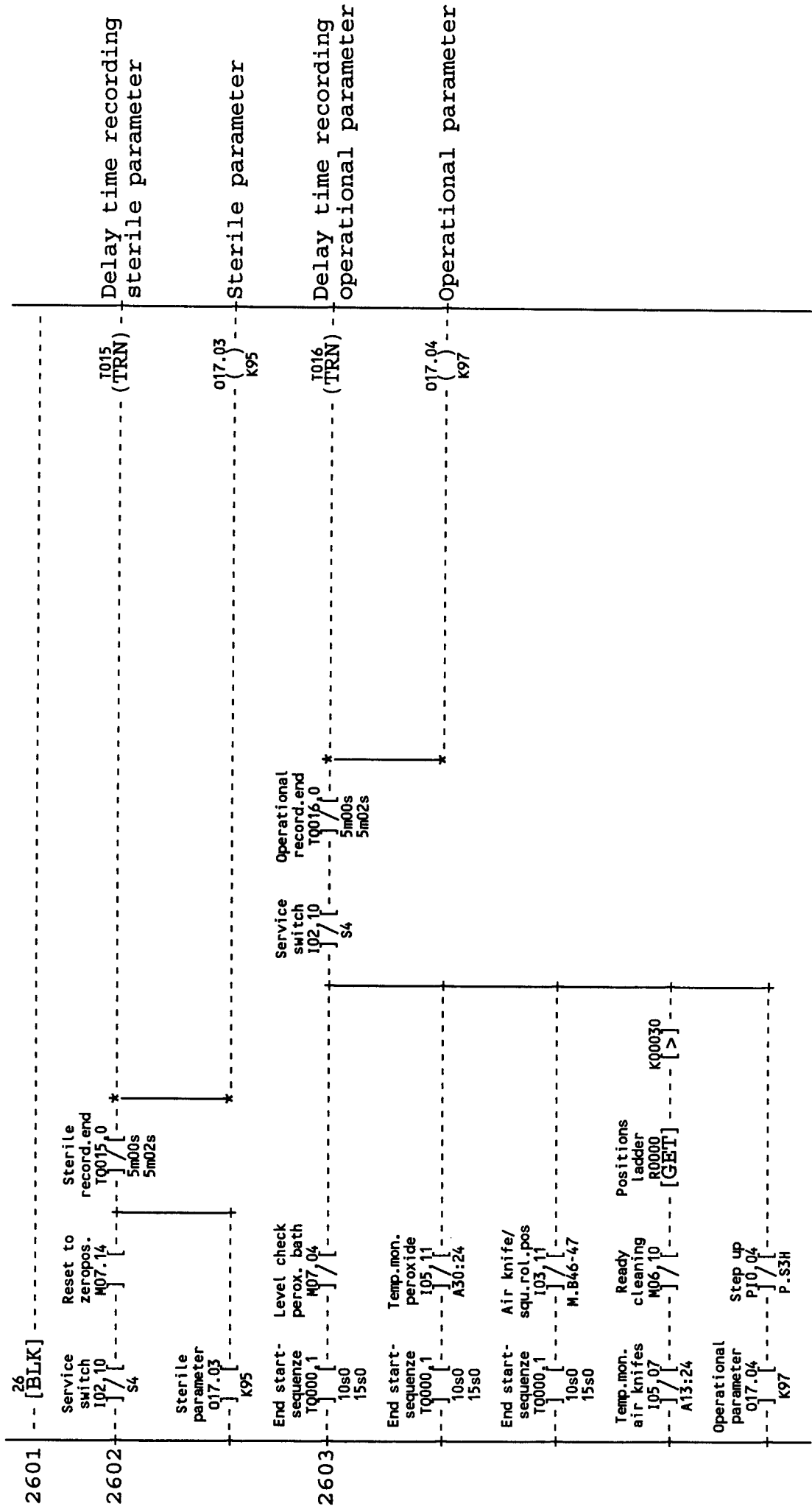

TBA/9-1401 S.A.

TPMC - PROGRAMME LIST

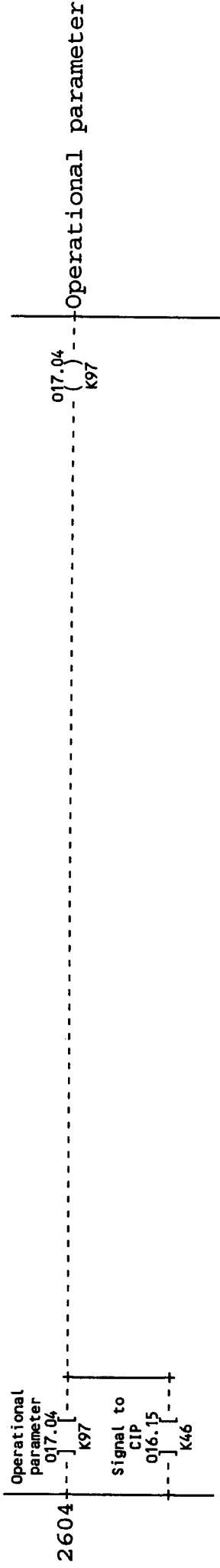

TBA/9-1401 S.A.

Sign: HK/MRI

Date: 940916

AM: 20555

47615-26:01

Page: 2  
Cont: --

TPMC-PROGRAMME LIST

MAINS INTERRUPT AND ALARMDELAYS

2701	27	[BLK]						
2702		Cool water pressure	Delay alarm waterpres.	M15.02				Waterpressure delay
2703		Storage word mainsfailur	Storage word mainsfailur	M13.01				Alarmdelay by restart after mainsinterrupt
2704		Restart mainsinter.	Delay mains to 0-pos.	R0254 (PUT)				Storage word time mainsinterrupt
2705		Storage word mainsfailur	Storage word mainsfailur	M13.00				Mainsinterrupt to long for sterile conditions
2706		Memory safety mon.	To Long mainsinter	O21.14 A25.A2				Restart at mainsfailure
2707		Emergency stops	First scan	M14.12				Memory safety monitors
2708		Emergency stops	Emergency stops	M14.12				Memory safety monitors

TPMC - PROGRAMME LIST

JUMP TO MACHINELADDERPOSITION "STERILIZATION FULLFILLED" (POSITION 3)

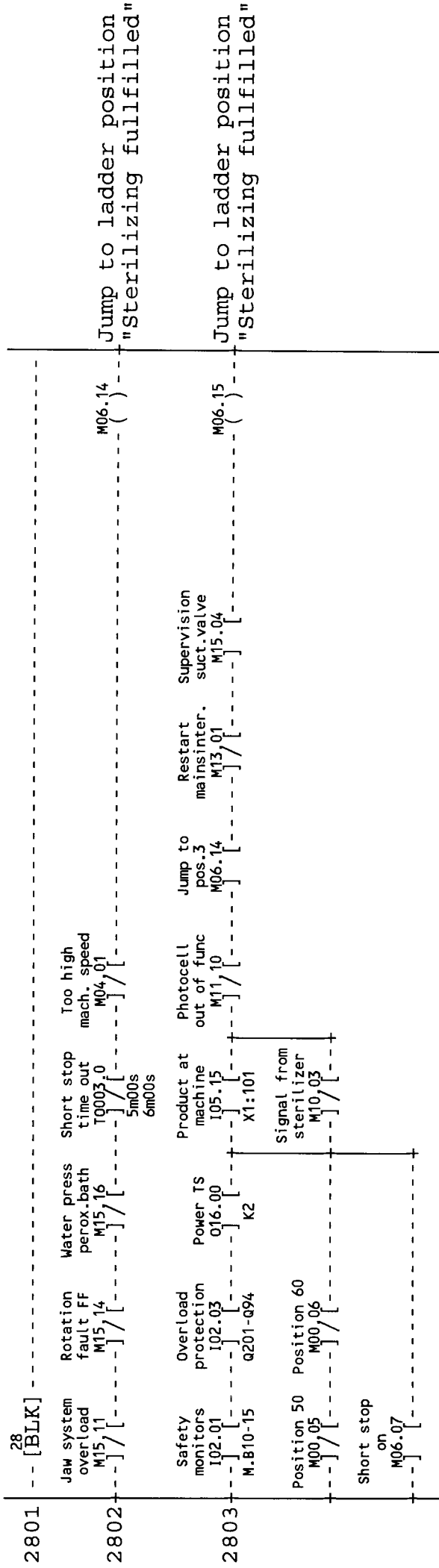

TPMC - PROGRAMME LIST

JUMP TO ZEROPOSITION IN MACHINELADDER

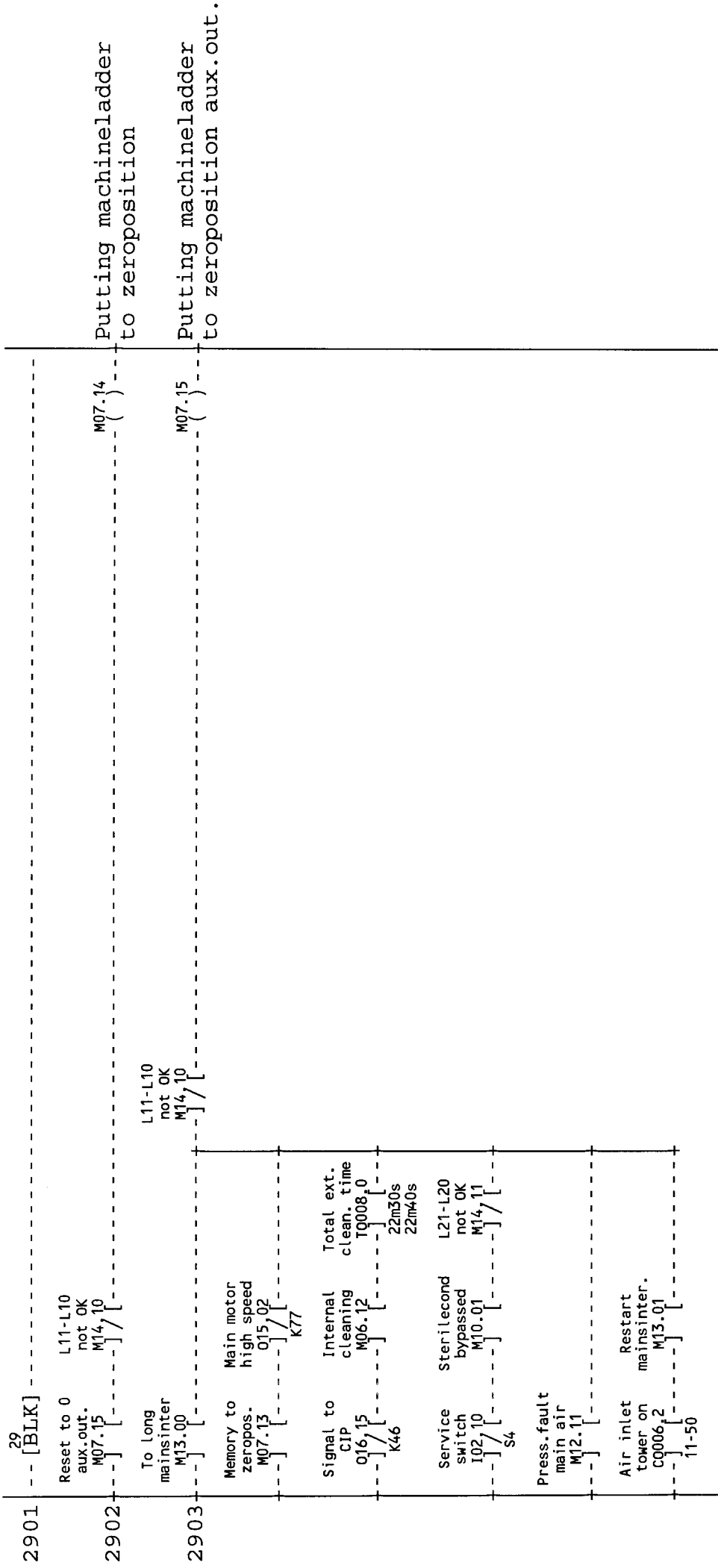

TPMC-PROGRAMME LIST

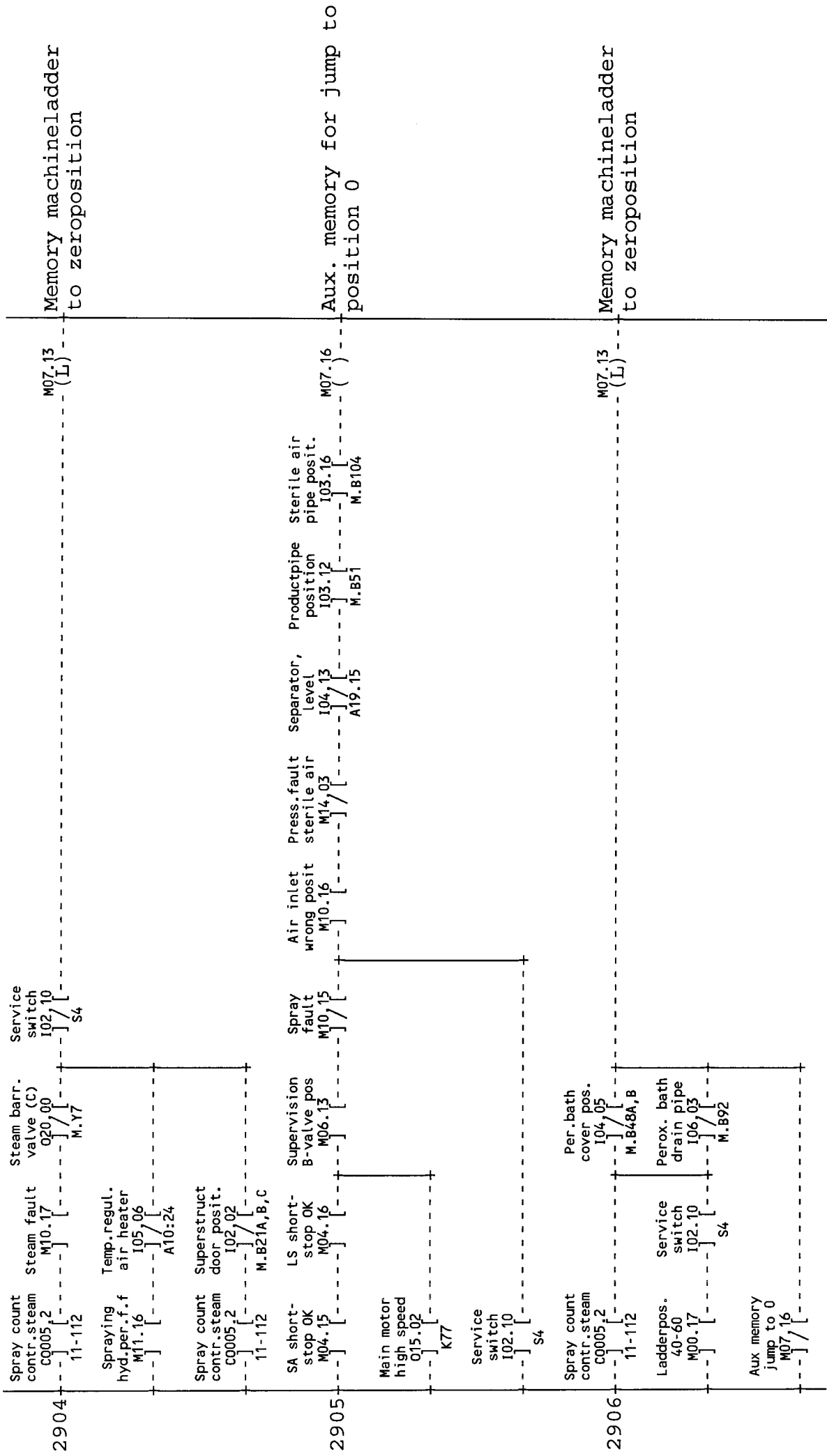

TPMC-PROGRAMME LIST

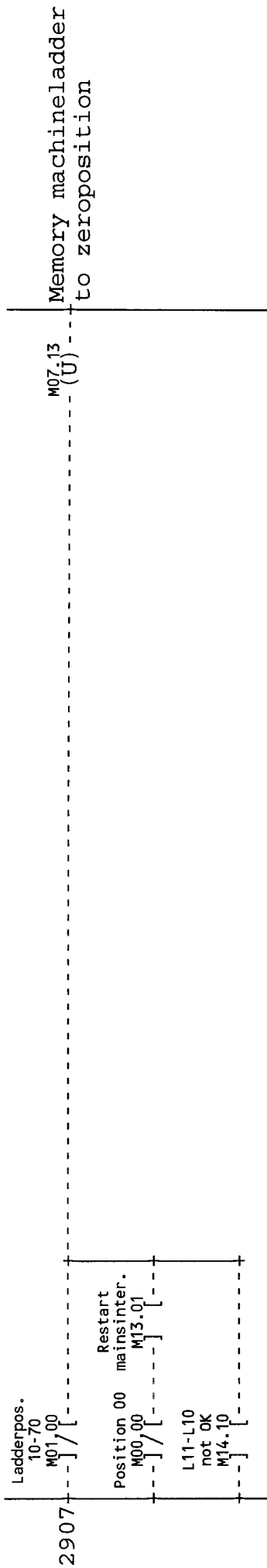

TPMC-PROGRAMME LIST

ALARM 1 TO 16 ON ALARMDISPLAY/BEACON

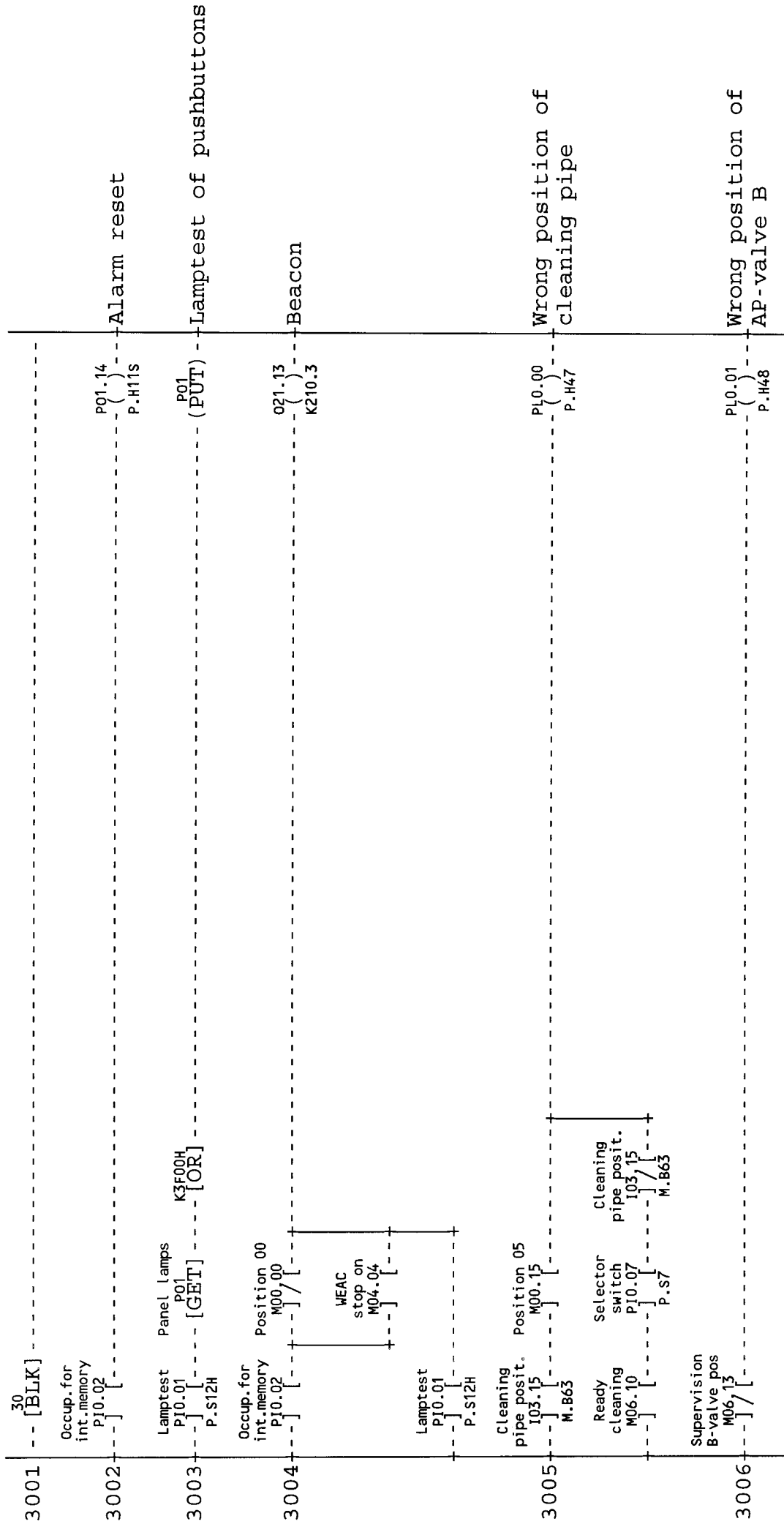

TPMC - PROGRAMME LIST

3007	<p>Spraying hyd.per.f.f M11.16</p> <p>Temp.regul. perox.water 105.02 A6:24</p>	<p>PL0.02 ( ) P.H53</p>	<p>Too low temperature peroxid bath, water</p>
3008	<p>Position 00 M00.00</p> <p>Productpipe position 103.12 M.B51</p> <p>Ready cleaning M06.10</p> <p>Selector switch P10.07 P.S7</p> <p>Sterile air pipe posit. 103.16 M.B104</p> <p>Sterile air pipe posit. 103.16 M.B104</p> <p>Ready cleaning M06.10</p> <p>Ready cleaning M06.10</p> <p>Selector switch P10.07 P.S7</p>	<p>PL0.03 ( ) P.H46</p>	<p>Wrong position of product pipe</p>
3009	<p>Temp.mon. peroxide 105.11 A30:24</p> <p>Contr.temp peroxide T0000.4 9s5 15s0</p>	<p>PL0.04 ( ) P.H52</p>	<p>Too low temperature peroxide</p>
3010	<p>Level check perox. bath M07.04</p> <p>End start-sequenze T0000.1 10s0 15s0</p> <p>Pulse stepup M02.00</p> <p>Position 70 M00.07</p> <p>Peroxide bath, level 104.12 A18.15</p>	<p>PL0.05 ( ) P.H49</p>	<p>Levelfault peroxide bath, peroxide</p>

TPMC-PROGRAMME LIST

3011	<p>Position 10 LS tubeseal M00.01</p> <p>Temp.regul. LS M05.03 A8:20</p> <p>Spraying hyd.per.f.f M11.16</p> <p>Temp.regul. LS M11.04 A8:24</p> <p>LS short-stop OK M04.16</p> <p>Water press perox.bath M15.16</p>	<p>P10.06 ( )</p> <p>P.H51</p>	<p>Too low temperature element LS</p>
3012	<p>Paperweb fault M15.12</p>	<p>P10.07 ( )</p> <p>P.H50</p>	<p>Too low level peroxide bath, water</p>
3013	<p>Ladderpos. 40-60 M00.17</p> <p>Product at machine M105.15</p> <p>Service switch M102.10</p> <p>X1:101 S4</p>	<p>P10.10 ( )</p> <p>P.H38</p>	<p>Rotation monitor paper web fault</p>
3014	<p>Ladderpos. 10-70 M01.00</p> <p>Strip supply M103.06</p> <p>M.B32</p>	<p>P10.11 ( )</p> <p>P.H45</p>	<p>No product from process available at machine</p>
3015	<p>Clean.steam barr.space M07.12</p>	<p>P10.12 ( )</p> <p>P.H41</p>	<p>Stripsupply of strip applicator too low</p>
3016	<p>Strip break M15.15</p>	<p>P10.13 ( )</p> <p>P.H44</p>	<p>Cleaning steam barrier space</p>
3017		<p>P10.14 ( )</p> <p>P.H40</p>	<p>Broken strip of stripapplicator</p>

TPMC - PROGRAMME LIST

3018	Position 05 M00.15	Steam fault M10.17	PI0.15 ( ) P.H43	Temperature out of limit steam
	Ladderpos. 10-70 M01.00			
	Selector switch PI0.07	Ready cleaning M06.10		
	P.S7			
	signal to CIP O16.15			
	K46			
3019	Preheating 1 S.A. 016.01	Temp.regul. SA I05.12	PI0.16 ( ) P.H39	Too low temperature at strip applicator
	K48	A202:24		
	SA short- stop OK M04.15			
3020	LS/RP element on I0001.2	Air knife/ squ.rol.pos I03.11	PI0.17 ( ) P.H42	Wrong position of squeezroller, air knife
	9s0 23s0	M.B46-47		

TPMC-PROGRAMME LIST

ALARM 17 TO 32 ON ALARMDISPLAY

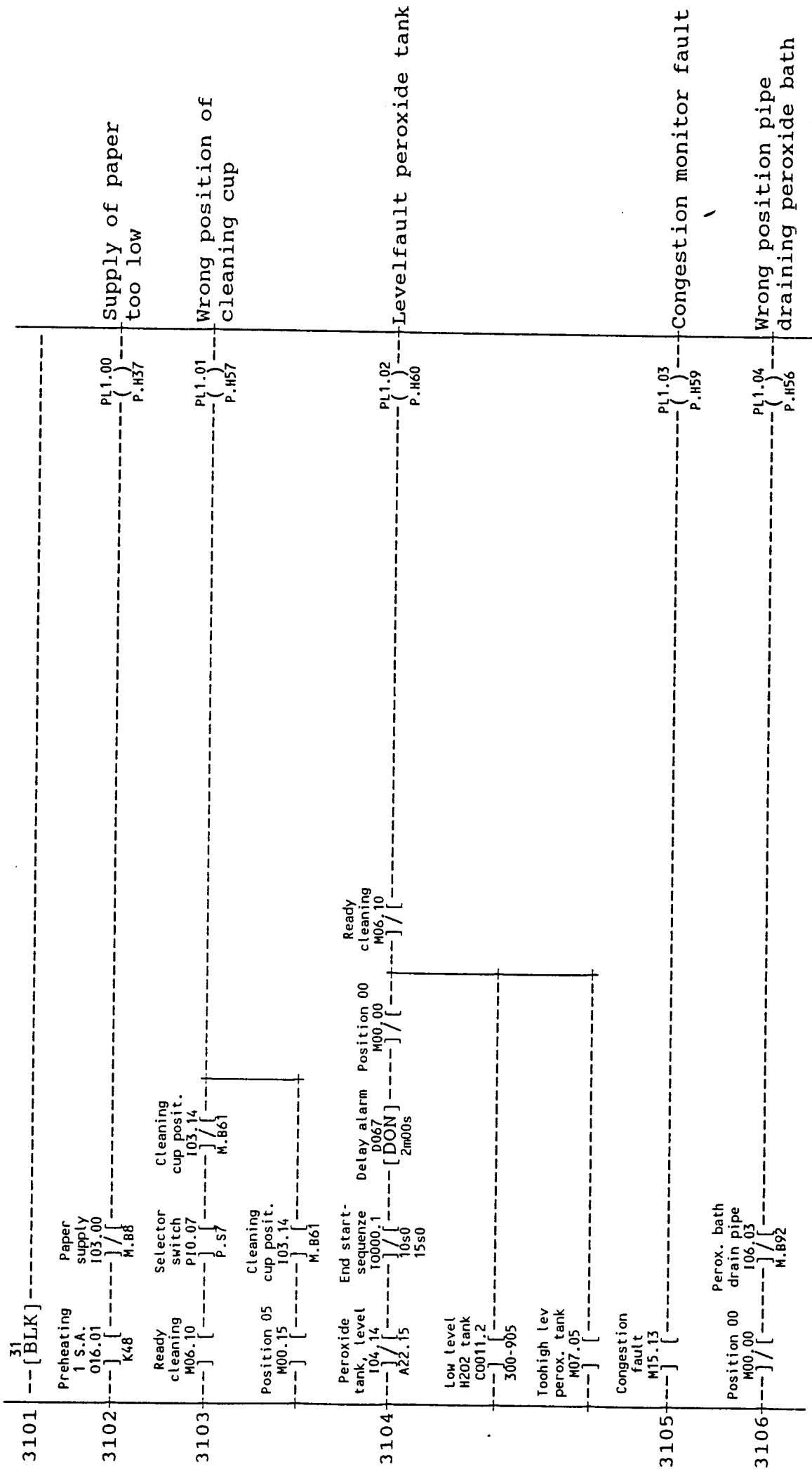

TPMC-PROGRAMME LIST

3107	<p>Position 70 out of des. monitor M00.07 / [ M11.11 ] [ C0001.2 ] [ 0-3 ]</p> <p>Photocell out of func M11.10</p>	<p>PL1.05 ( ) P.H55</p>	<p>Position printed design out of limits</p>
3108	<p>Fault in IH-units TS M11.01</p>	<p>PL1.06 ( ) P.H58</p>	<p>Fault IH-units transversal sealing</p>
3109	<p>Ladderpos. 10-70 M01.00</p> <p>Per. bath cover pos. 104.05 M.848A,B</p>	<p>PL1.07 ( ) P.H54</p>	<p>Wrong position of bottom cover peroxid bath</p>
3110	<p>Low battery TPMC M37.15</p> <p>Scantime 80% exceed. M37.16</p>	<p>PL1.10 ( ) P.H25</p>	<p>Low battery TPMC, or scantime 80% exceeded</p>
3111	<p>Position 00 M00.00</p> <p>L21-L20 Superstruct not OK door posit. M14.11 / [ 102.02 ] [ M.821A,B,C ]</p>	<p>PL1.11 ( ) P.H14</p>	<p>Monitor supervision position of tower doors</p>
3112	<p>Too high mach. speed M04.01</p>	<p>PL1.12 ( ) P.H24</p>	<p>Machine speed too high</p>
3113	<p>Jaw system overload M15.11</p>	<p>PL1.13 ( ) P.H15</p>	<p>Overload jaw system</p>



TPMC - PROGRAMME LIST

ALARM 33 TO 48 ON ALARMDISPLAY

3201	32 [BLK]				
3202	Separator, Level I04.13 A19.15			PL2.01 ( ) P.H30	Too high level separators
3203	Air super- heater 016.02 K71	Air heater preheating I05.05 A10:20	Spraying hyd.per.f.f M11.16	PL2.02 ( ) P.H31	Too low temperature at air heater
		Temp.regul. air heater I05.06 A10:24	Spraying hyd.per.f.f M11.16		
3204	Supervision suct.valve M15.04			PL2.03 ( ) P.H33	Wrong position of suction valve
3205	Spraytank fill.fault M04.02			PL2.04 ( ) P.H34	Spray time out of limits or HI fault
	Spray fault M10.15				
3206	Closing of AP-valve(B) C0007.1 1080-1210	Temp.mon. air knives I05.07 A13:24		PL2.05 ( ) P.H35	Too low temperature at air knife
3207	Air inlet wrong posit M10.16			PL2.06 ( ) P.H36	Wrong position of inlet valve

TPMC- PROGRAMME LIST

3208	Press.fault sterile air M14.03	PL2.07 ( ) P.H32	Pressurefault sterile air
3209	Queue monitor M15.03	PL2.10 ( ) P.H63	PLE-equipment
3210	Levelfault cleantray M10.05	PL2.11 ( ) P.H62	Too low level clean tray
3211	Rotation fault FF M15.14	PL2.13 ( ) P.H61	Rotation fault final folder

TPMC - PROGRAMME LIST

ALARM 49 TO 64 ON ALARMDISPLAY

3301	[BLK]				
	L21-L20 not OK M14,11	Lubr oil low level I02,15			
3302					Too low level lubrication oil
		M.B30:A		PL3.10 ( ) P.H21	
	Waterpress. delayd M15,02		L21-L20 not OK M14,11		
3303					Too low pressure cooling water
	Position 00 M00,00	Cool water pressure I02,13	Long lubr. per.ordered M11,07	PL3.11 ( ) P.H10	
		M.B7			
3304					Wrong pressure lubrication oil
	Position 00 M00,00	Wrong press lubrication M10,07		PL3.12 ( ) P.H20	
3305					Pressurefault main air
	Press.fault main air M12,11			PL3.13 ( ) P.H11	
	Service switch I02,10	L21-L20 not OK M14,11			Service switch in on position
3306					
				PL3.14 ( ) P.H19	
	Superstruct door posit. I02,02	L21-L20 not OK M14,11	Safety monitors I02,01		Safety monitors in of position
3307					
	M.B21A,B,C	Position 00 M00,00	M.B10-15	PL3.15 ( ) P.H12	
		Crank pos. I02,05	M.B10		

TPMC - PROGRAMME LIST

3308	<p>OverLoad protection I02.03 q201-q94</p> <p>Overl.-prot compr, fan I04.01 q87,98,99</p>	<p>Emergency stops I03.03 M.S4, S32,</p> <p>L11-L10 not OK M14,10</p>	<p>L21-L20 not OK M14,11</p>	<p>PI3.16 ( ) P.H18</p>	<p>Tripped overload protection of motors</p>
3309	<p>Emergency stops I03.03 M.S4, S32,</p>			<p>PI3.17 ( ) P.H13</p>	<p>Activated emergency stop</p>

TPMC - PROGRAMME LIST

9001 | <sup>90</sup> --- [BLK] ----- |

TPMC-PROGRAMME LIST

FAST FUNCTIONS, TS, DESIGN PULSE

9901	99	[BLK]						
		Transversal sealing on	Storage word TS sealing					
		M10.06	R0100	K00180	K00001			Storage word for Transversal sealing
9902		[GET]	[<]	[+]				
		Transversal sealing						
		S00.04	K00000					Storage word for Transversal sealing
9903		[GET]	[GET]					
		114-223						
		314-23						
		Fault in IH-units TS						
		M11.01						
		[ ]						
		Storage word TS sealing						
		S00.02	R0100	K00010	K00180			Sealing pulse TS left
9904		[GET]	[>]	[<]				
		100-277						
		Side change						
		S00.02	R0100	K00010	K00180			Sealing pulse TS right
9905		[GET]	[>]	[<]				
		100-277						
		Storage word TS sealing						
		S00.02	R0100	K00010	K00180			
9906		[GET]	[>]	[<]				
		100-277						
		Side change						
		S00.02	R0100	K00010	K00180			
9907		[GET]	[>]	[<]				
		100-277						
		Storage word TS sealing						
		S00.02	R0100	K00010	K00180			
		Side change						
		S00.02	R0100	K00010	K00180			
		Delay						
		design sign						
		106.00	M05.05					
		[P+]						
		A16A:3						
		6-14						
		206-214						
		VOLUME DEPENDENT VALUE. VALID FOR 200CC, FOR OTHER VOLUME SEE:47615-03:01						
		M11.12						Auxiliary output precorrection off
		[END]						